

# SS12

## *Generator Automatic Voltage Regulator Operation Manual*



*Self Excited Automatic Voltage Regulator  
5 Amp AVR For Full Wave Generators*

# 1. INTRODUCTION

## Sensing & power Input

Voltage 160 ~ 260 VAC, 1 phase 2 wire  
Frequency 50 / 60 Hz, selectable

## Output

Voltage Max. 170 VDC @ 240 VAC input  
Current Continuous 5A  
Intermittent 7A for 10 sec  
Resistance Min. 15 ohm Max. 100 ohm

## Voltage Regulation

< ± 1% ( with 4% engine governing )

## Voltage Build-up

Residual voltage at AVR terminal > 3 VAC

## Thermal Drift

0.03% per °C change in AVR ambient

## External Volts Adjustment

± 10% with 5K ohm 1 watt trimmer

## Unit Power Dissipation

Max. 8 watt

## Under Frequency Protection (Factory Setting)

60 Hz system presets knee point at 55 Hz  
50 Hz system presets knee point at 45 Hz

## Soft Start Ramp Time

2 sec.

## Dimensions

150mm L \* 100mm W \* 74mm H

## Weight

421g ± 2%

# 2. WIRING (Refer to Fig4, Fig5)

- fi Linked the generator field to F+ and F-.
- fi Linked sensing input to "AC".
- fi Linked external trimmer to "Ext.VR".
- fi Selected 50Hz or 60 Hz system.

## 3. NOTE

### 3.1 Note before installation (Refer to Fig1)

### 3.2 Note when generator running

- fi The temperature of AVR may be over 60°C when generator set is running.
- fi Please don't touch the heat-sink there is a warning mark, when generator set is running.

### 3.3 Procedure of generator running

#### 3.3.1 Setting

1. Check the connect wires are correct.
2. Check protect fuse is 15A 250V.
3. Turn the volt trimmer fully anticlockwise.
4. Turn the external trimmer to midway position if fitted.
5. Turn the stability trimmer fully anticlockwise.

6. Connect a 110VDC voltmeter to field F+, F- terminals.
7. Connect a 300VAC voltmeter to generator output voltage terminals.

#### 3.3.2 Start the generator

1. Start generator with no load. Adjust the speed at correct position.
2. Carefully turn volt trimmer clockwise until rated voltage is reached.
3. Turn stability trimmer clockwise until the output voltage is not stable, carefully turn stability trimmer anticlockwise until rated stable voltage is reached. That is the best match point between AVR and generator.

# 4. ADJUSTMENT

## 4.1 Under frequency adjustment

- fi Linked " COM ,50Hz " terminals at 60Hz system, open when 50Hz.
- fi Under frequency setting procedure, if necessary.
  1. Start the generator set and the output voltage is normally.
  2. Adjust the generator speed controller until under frequency point is reached.

- Turn U/F trimmer until the U/F LED is illuminated. ( 50Hz is setting at 45Hz,60Hz is setting at 55Hz when outgoing ).

#### 4.2 Voltage adjustment

- Turn volt trimmer until rated voltage is reached.
- Install an external VR 500Ω 1 watt between “ Ext.VR ” terminal, if necessary.

#### 4.3 Stability adjustment

- Turn stability trimmer until output voltage is stable.

### 5. FIELD FLASHING

When the regulator is operated for the first time, the polarity of residual magnetism may be reversed or too small to achieve the necessary build-up voltage for the regulator. If reversing the field connections does not induce build-up, and the residual voltage is less than the specified value of 5 VAC, shut

down the Prime-mover and proceed with the following steps :

- With the Prime-mover at rest and the regulator’s field output wires disconnected, apply a DC source ( NOT grounded ) of not more than 3~12 VDC with Positive to F+ and Negative to F-, in series with a current-limiting resistor of 3~5 ohms 20 watt. (The set battery is a suitable source.)
- Allow approximately 3 seconds before removing the DC source.
- With the voltage regulator disconnected ( wires 3 and 4 ), start the prime mover and measure the “ residual ” voltage available at the auxiliary winding. If this voltage is greater than 5 VAC, reconnect voltage regulator, and voltage build-up should be successful. If less than 5 VAC is measured, repeat field flashing procedure.
- If repeating steps a. and b. does not result in generator voltage build-up, and residual is greater than 5 VAC, replace voltage regulator.

#### WARNING

This Automatic Voltage Regulator is not equipped with loss-Sensing Protection function / Over Excitation Protection. An additional Over-Voltage Protection device for load may be required to avoid possible damage to the equipment or severe personal injury or death.

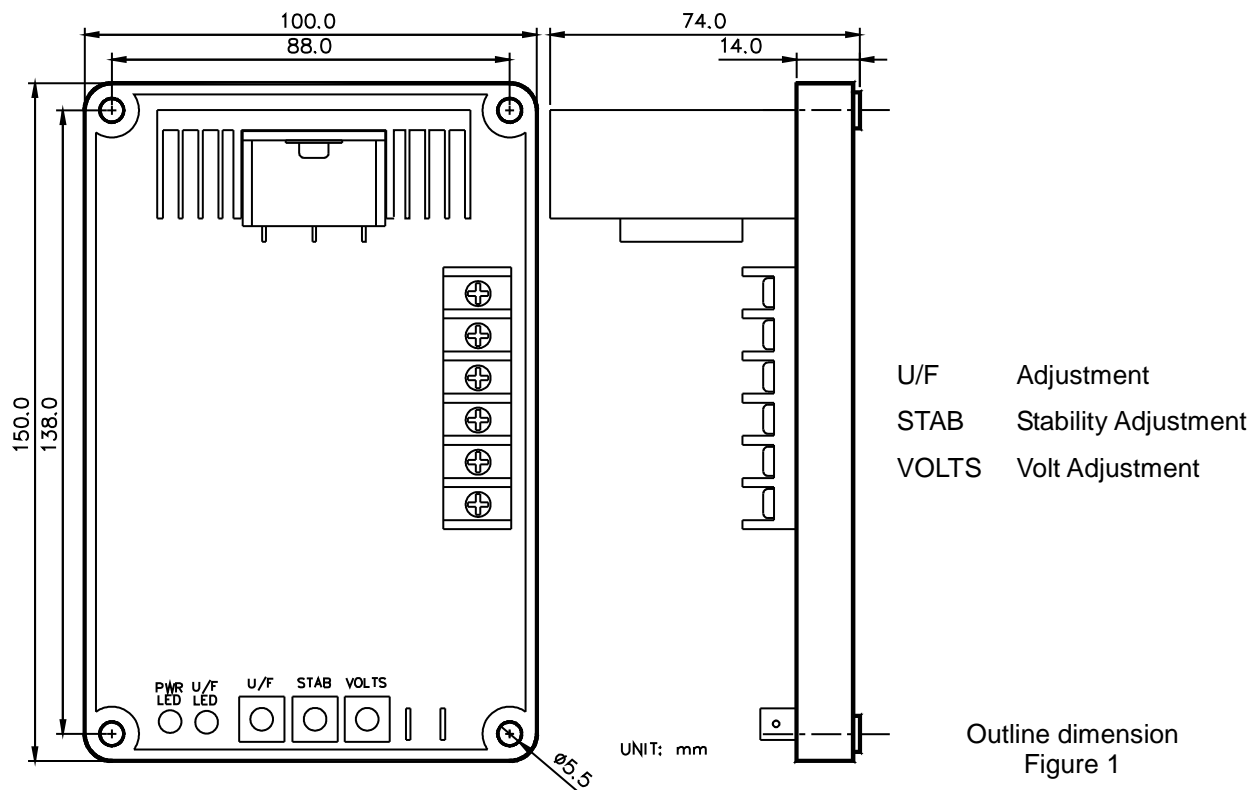

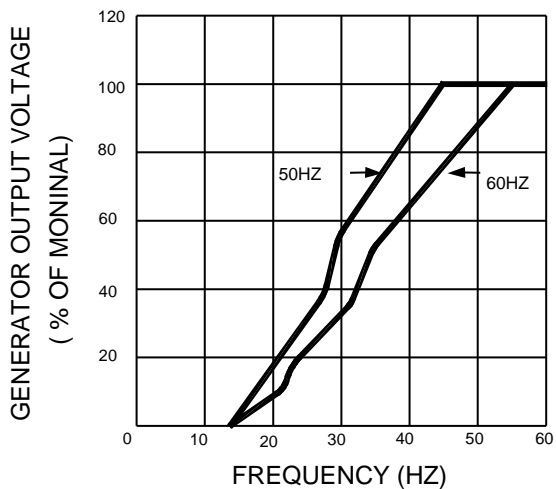

Frequency Compensation Curves  
Figure 2

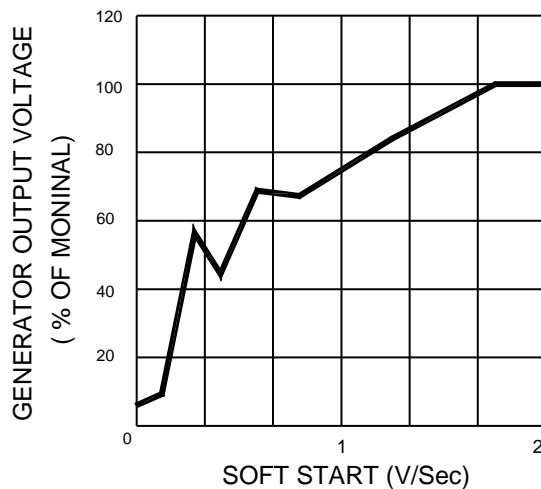

Soft Start Curve  
Figure 3

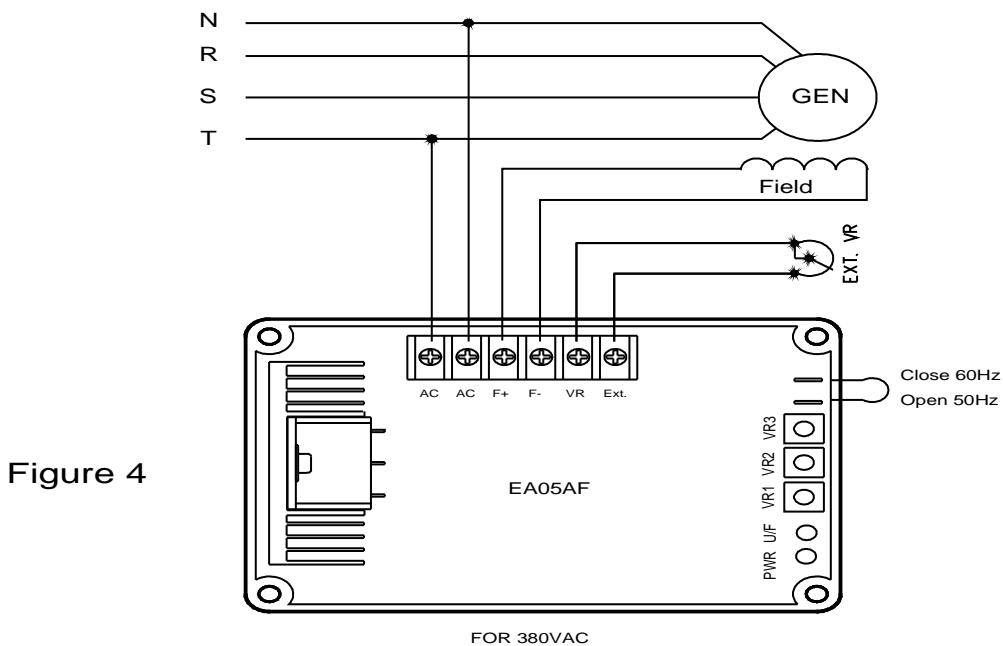

Figure 4

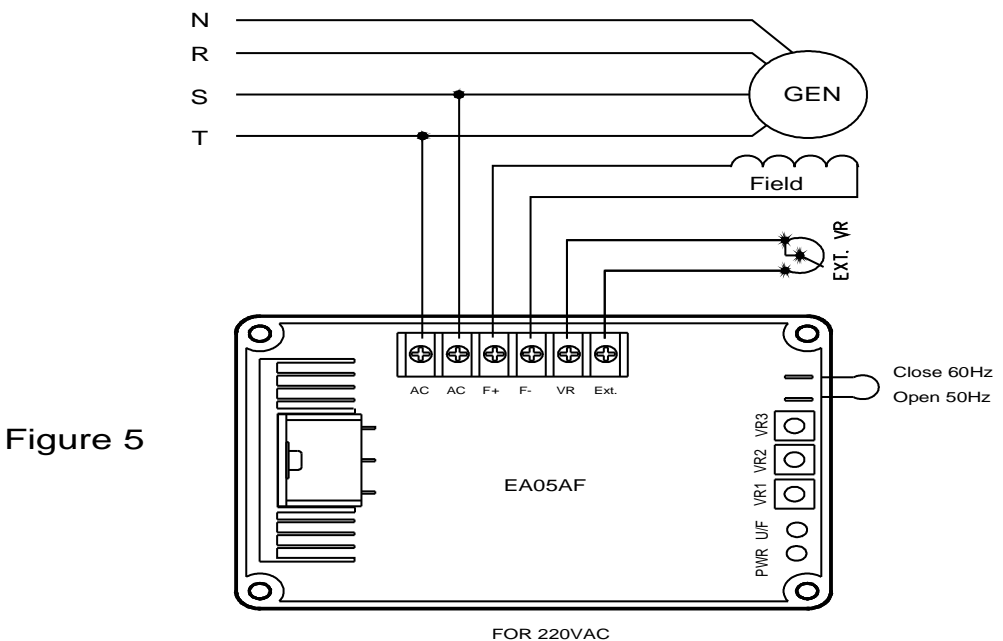

Figure 5