

TS 910 & TS 920

AUTOMATIC TRANSFER SWITCHES

INSTALLATION, OPERATING, & SERVICE MANUAL

TABLE OF CONTENTS

1	PRODUCT REVISION HISTORY	1
2	EQUIPMENT STORAGE	1
3	NOTES TO INSTALLER	2
3.1	APPLICATION	2
3.2	CHECK EQUIPMENT DELIVERY	2
3.3	CHECK LINE VOLTAGE/AMPERAGE	3
3.4	INSTALLATION REQUIREMENTS	3
3.5	DIELECTRIC TESTING	7
3.6	SERVICE DISCONNECT ATS CONFIGURATION	8
4	GENERAL DESCRIPTION	9
4.1	PRODUCT MODEL CODE	10
4.2	TS 910/920 OPTIONAL ACCESSORIES	11
4.3	TYPICAL COMMISSIONING PROCEDURES	11
5	GENERAL THEORY OF OPERATION	12
5.1	AUTOMATIC SEQUENCE OF OPERATION	12
5.2	SERVICE ENTRANCE AUTOMATIC TRANSFER SWITCH OPERATION	12
6	OVER CURRENT PROTECTION	15
6.1	STANDARD TS 910/920 AUTOMATIC TRANSFER SWITCH	15
6.2	SERVICE ENTRANCE RATED TS 910/920 AUTOMATIC TRANSFER SWITCH	15
7	GENERAL NOTES ON SERVICING TRANSFER SWITCH MECHANISM	16
8	TRANSFER SWITCH MECHANISM OPERATION	16
8.1	AUTOMATIC OPERATION	16
8.2	MANUAL OPERATION	17
9	RECOMMENDED MAINTENANCE	19
10	FRONT INTERIOR VIEW (100A STANDARD ATS)	20

11	FRONT INTERIOR VIEW (100A SERVICE ENTRANCE ATS)	21
12	FRONT <i>INTERIOR</i> VIEW (200A STANDARD ATS)	22
13	FRONT INTERIOR VIEW (200A SERVICE ENTRANCE ATS)	23
14	FRONT INTERIOR VIEW (400A STANDARD ATS)	24
15	FRONT INTERIOR VIEW (400A SERVICE ENTRANCE ATS)	25
16	ENCLOSURE DIMENSIONS	26
17	POWER CONDUCTOR INSTALLATION	27
18	REQUIREMENTS FOR UPSTREAM CIRCUIT PROTECTIVE DEVICES	28
18.1	100A, 2P NON-SERVICE ENTRANCE ATS UPSTREAM CIRCUIT PROTECTIVE DEVICES	29
18.2	100A, 3P NON-SERVICE ENTRANCE ATS UPSTREAM CIRCUIT PROTECTIVE DEVICES	30
18.3	200A, 2P NON-SERVICE ENTRANCE ATS UPSTREAM CIRCUIT PROTECTIVE DEVICES	32
18.4	200A, 3P NON-SERVICE ENTRANCE ATS UPSTREAM CIRCUIT PROTECTIVE DEVICES	32
18.5	400A, 2P/3P NON-SERVICE ENTRANCE ATS UPSTREAM CIRCUIT PROTECTIVE DEVICES	34
19	TSC 9 TRANSFER SWITCH CONTROLLER	36
19.1	DESCRIPTION	36
19.2	ELECTROSTATIC DISCHARGE PRECAUTIONS	37
19.3	DIELECTRIC TESTING	37
19.4	TSC 9 FACEPLATE	38
19.5	TSC 9 FACEPLATE LIGHTS AND PUSHBUTTON OPERATION	39
19.6	TSC 9 PRINTED CIRCUIT BOARD	40
19.7	TSC 9 OPERATING INSTRUCTIONS	44
19.8	TSC 9 OPERATING MODE DESCRIPTIONS	45
19.9	TEST MODES	48
19.10	TRANSFER FAIL FAULT RESET	50

19.11	LAMP TEST	50
19.12	TIMER BYPASS	51
19.13	TSC 9 VOLTAGE SENSING	51
19.14	TSC 9 SYSTEM FREQUENCY DETECTION	51
19.15	TSC 9 GENERATOR FREQUENCY SENSING	51
19.16	TSC 9 CONFIGURATION INSTRUCTIONS	52
19.17	LOAD SHED	57
20	BHP OPERATOR INTERFACE PANEL (TS 920 SERIES ONLY)	59
20.1	DESCRIPTION	59
21	TS 910/TS 920 SCHEMATIC DIAGRAM	60
22	TROUBLESHOOTING	61
23	REPLACEMENT PARTS	62
24	PRODUCT RETURN POLICY	64
25	NOTES	65
26	APPENDIX A – TYPICAL AUTOMATIC TRANSFER SWITCH COMMISSIONING PROCEDURES	66
a)	PRE-ENERGIZATION CHECKS	66
b)	EQUIPMENT ENERGIZATION	67

1 PRODUCT REVISION HISTORY

The following information provides an historical summary of changes made to this product since the original release.

Owners Manual Version

Rev 0 14/02/27	Original release (Added TS 920 Series to TS 910 Series Manual)
Rev 1 16/07/27	Revise Short Circuit Current Ratings, Power Cable Sizes and torque information (<i>SECTION 17</i>)
Rev 2 16/10/07	Add changes to reflect revised TSC 9 Firmware version r245 (phase rotation indication, and revised frequency threshold)
Rev 3 17/02/15	Correct warmup, utility return and cooldown timer minimum time settings
Rev 4 20/10/23	Updated series breaker list

Contact Thomson Power Systems, to obtain applicable instruction manuals or if in doubt about any matter relating to installation, operation or maintenance. Soft copy of the most current version is available at www.thomsonps.com.

NOTE: All information contained in this manual is for reference only and is subject to change without notice.

2 EQUIPMENT STORAGE

The following procedures are required for correct storage of the transfer switch prior to installation.

CAUTION

Failure to store equipment under the specified environmental conditions may cause equipment damage and void warranty.

The transfer switch shall be stored in an environment with a temperature range not exceeding -4° to +158° Fahrenheit (-20° to +70° Celsius) and a humidity range not exceeding 5%-95% non-condensing. Before storing, unpack sufficiently to check for concealed damage. If concealed damage is found, notify the ATS supplier and the Carrier immediately. Repack the transfer switch with the original packing material (or equivalent). Protect from physical damage. Do not stack. Store indoors in a clean, dry, well ventilated area free of corrosive agents including fumes, salt and concrete/cement dust. Apply heat as necessary to prevent condensation.

3 NOTES TO INSTALLER

DANGER

Arc Flash and Shock Hazard. Will cause severe injury or death.

Do not open equipment until ALL power sources are disconnected

This equipment must be installed and serviced only by qualified electrical personnel utilizing safe work practices and appropriate Personal Protective Equipment (PPE). Failure to do so may cause personal injury or death

3.1 APPLICATION

3.1.1 TS 910 Residential Transfer Switch

The TS 910 Transfer Switch is designed and is Listed by Underwriters Laboratories (UL) to Safety Standard UL 1008 for Transfer Switches for Optional Standby applications only. This product is not intended for installation or operation on legally required standby applications for emergency power systems as defined by the National Electrical Code.

3.1.2 TS 920 Light Commercial Transfer Switch

The TS 920 Transfer Switch is designed and is Listed by Underwriters Laboratories (UL) to Safety Standard UL 1008 for Transfer Switches for Emergency Standby applications. This product is intended for installation or operation on legally required standby applications for emergency power systems as defined by the National Electrical Code.

3.2 CHECK EQUIPMENT DELIVERY

Upon delivery of the transfer switch, remove the product packaging and verify the product has not been damaged.

WARNING

Damaged Transfer Switch equipment: Do not install or operate the transfer switch if it appears damaged. Failure to follow these instructions can result in death, serious injury, or equipment damage.

Check that the model number printed on the inside cover of the transfer switch is the same as on the delivery note corresponding to the purchase order.

3.3 CHECK LINE VOLTAGE/AMPERAGE

The transfer Switch is designed for a maximum voltage of 120/240V, Single Phase 3 wire with neutral or 120/208V, 3 phase 4 wire with neutral. Verify the line voltage and amperage of the transfer switch matches the site requirements.

NOTE: The transfer switch can be configured for operation on 208V or 220V sources by way of configuration jumper. Refer to [SECTION 19.15](#) Configuration Jumpers, of this manual for further information.

WARNING

Do not install the transfer switch if either voltage or amperage does not match. Failure to follow these instructions can result in death, serious injury, or equipment damage.

3.4 INSTALLATION REQUIREMENTS

Before installing the transfer switch, review the following requirements:

3.4.1 Installation Codes/Permits and ATS Sizing

Suitable permits are typically required by local jurisdictions having authority prior to installing standby generator sets and automatic transfer switches. Per NEC Article 702, Automatic transfer switches shall be sized for either a) entire load whole house, load calculation per NEC 220, or b) Pre-selected "EM" panel(s) of load being served or optional standby panel and transfer switch, or c) automatic load shedding feature to reduce total load imposed on the generator, not to exceed the capacity of the generator. The TS 910/920 transfer switch has automatic load shedding capabilities built-in when load shedding control contact is connected. Refer to Load Shedding section of this manual for further details.

3.4.2 Installation Location

The standard TS 910/920 transfer switch is designed for indoor wall mounting. For applications requiring outdoor wall mounting, a NEMA 3R door kit is optionally available. The transfer switch must be installed in an environment where the temperature range is within +5° to +122° Fahrenheit (-15° to +50° Celsius) and humidity range not exceeding 5%-95% non-condensing.

NOTE: For correct voltage sensing operation on High Leg Delta systems, the TSC 9 controller must have the configuration jumpers set at “240V” and “3PH” settings. Refer to [SECTION 19.15](#) TSC 9 Configuration Instructions of this manual for further details.

3.4.5 Control Wiring

All control wiring for engine start, load shed, alarm and remote test must be installed in separate conduits from all power cabling and must utilize suitably sized conduits per NEC requirements. All control wiring shall be sized for minimum #14 AWG. Control wiring type and voltage rating must also comply with NEC requirements and local jurisdictions having authority.

3.4.6 Generator Set Automatic Operation

The standard TS 910/920 transfer switch operates in conjunction with any generator set with remote automatic starting capabilities utilizing a 2 wire, remote start control contact input. A dry contact is provided for remote generator starting control (contact closes to start generator and opens to stop generator).

As an optional add-on, there is a Universal Generator Interface kit (**UGI**) which allows the TS 910/920 transfer switch to be applied to multiple types of generator sets utilizing 240V remote starting control systems. Additional information on the Universal Generator Interface kit can be obtained from our Website (www.thomsonps.com).

3.4.7 Upstream Over Current Protection (Non-Service Entrance Rated TS 910/920)

Non-Service Entrance Rated TS 910/920 transfer switch models do not contain any integral over current protection and require upstream over current protection devices for both Utility and Generator sources. The standard TS 910/920 series Automatic Transfer Switch is rated for 100% system load and is suitable for control of motors, electric discharge lamps, tungsten filament lamps, and electric heating equipment where the sum of motor full-load ampere ratings and the ampere ratings of other loads do not exceed the ampere rating of the switch and the tungsten load does not exceed 30 percent of the switch rating. Refer to [SECTION 18](#) Requirements For Upstream Circuit Protective Devices of this manual for further details.

3.4.8 Upstream Over Current Protection (Service Entrance Rated TS 910/920)

Service Entrance rated TS 910/920 transfer switch models contain integral over current protection for the Utility source as standard. Service Entrance rated TS 910/920 transfer switches do not contain any integral over current protection for the generator source and requires upstream generator source over current protection. The Service Entrance rated TS 910/920 is rated for 80% maximum continuous loading of all load types. Refer to [SECTION 18](#) Requirements For Upstream Circuit Protective Devices of this manual for further details.

3.4.9 Withstand/Interrupting Current Ratings

3.4.9.1 TS 910 Residential Transfer Switch

Refer to electrical ratings table shown below for withstand/Interrupting current ratings. Withstand/Interrupting short circuit current ratings shown Table 1, below, require use of specific types/manufacturers of upstream molded case circuit breakers. Refer to [SECTION 18](#) Requirements For Upstream Circuit Protective Devices of this manual for further details. Short circuit currents listed for Standard type ATS are Withstand ratings. Short circuit currents listed for Service Entrance type ATS are Interrupting ratings based on the ratings of the supplied utility service disconnect circuit breaker utilized.

WARNING

Do not install the transfer switch on systems with higher available short circuit current levels than listed below.

Failure to follow these instructions can result in death, serious injury, or equipment damage.

MODEL	ATS TYPE	POLES	MAX VOLTAGE	AMPERAGE	SHORT CIRCUIT CURRENT ¹
TS912A0100A	STANDARD	2	240V	100A	10kA
TS912A0100B	SERVICE ENTRANCE	2	240V	100A	10kA
TS912A0200A	STANDARD	2	240V	200A	10kA
TS912A0200B	SERVICE ENTRANCE	2	240V	200A	10kA
TS912A0400A	STANDARD	2	240V	400A	50kA ²
TS912A0400B	SERVICE ENTRANCE	2	240V	400A	25kA
TS913A0100A	STANDARD	3	240V	100A	22kA ²
TS913A0100B	SERVICE ENTRANCE	3	240V	100A	10kA
TS913A0200A	STANDARD	3	240V	200A	25kA ²
TS913A0200B	SERVICE ENTRANCE	3	240V	200A	10kA
TS913A0400A	STANDARD	3	240V	400A	50kA ²
TS913A0400B	SERVICE ENTRANCE	3	240V	400A	25kA

¹ AMPS RMS Symmetrical

² When protected by a specific upstream circuit breaker (refer to [SECTION 18](#))

TABLE 1 TS 910 Withstand/Interrupting Current Ratings

3.4.9.2 TS 920 Light Commercial Transfer Switch

Refer to electrical ratings table shown below for withstand/Interrupting current ratings. Withstand/Interrupting short circuit current ratings shown in Table 2, below, require use of specific types/manufacturers of upstream molded case circuit breakers. Refer to [SECTION 18](#) Requirements For Upstream Circuit Protective Devices of this manual for further details. Short circuit currents listed for Standard type ATS are Withstand ratings. Short circuit currents listed for Service Entrance type ATS are Interrupting ratings based on the ratings of the supplied utility service disconnect circuit breaker utilized.

WARNING

Do not install the transfer switch on systems with higher available short circuit current levels than listed below.

Failure to follow these instructions can result in death, serious injury, or equipment damage.

MODEL	ATS TYPE	POLES	MAX VOLTAGE	AMPERAGE	SHORT CIRCUIT CURRENT ¹
TS923A0100A	STANDARD	3	240V	100A	22kA ²
TS923A0100B	SERVICE ENTRANCE	3	240V	100A	10kA
TS923A0200A	STANDARD	3	240V	200A	25kA ²
TS923A0200B	SERVICE ENTRANCE	3	240V	200A	10kA
TS913A0400A	STANDARD	3	240V	400A	50kA ²
TS923A0400B	SERVICE ENTRANCE	3	240V	400A	25kA

¹ AMPS RMS Symmetrical

² When protected by a specific upstream circuit breaker (refer to *SECTION 18*)

TABLE 2 TS 920 Withstand/Interrupting Current Ratings

3.5 DIELECTRIC TESTING

Do not perform any high voltage dielectric testing on the transfer switch with the TSC 9 controller connected into the circuit as serious damage will occur to the controller. The control circuit isolation plug connected to the TSC 9 must be removed if high voltage dielectric testing is performed on the transfer switch.

3.6 SERVICE DISCONNECT ATS CONFIGURATION

If the transfer switch is ordered with Service Entrance rating type and is to be used as Service Equipment, following the procedure described below:

WARNING

The transfer switch must be de-energized prior to opening the enclosure to access Neutral Bonding strap. Failure to follow these instructions can result in death or serious injury.

1. Connect the Bonding Strap to Neutral

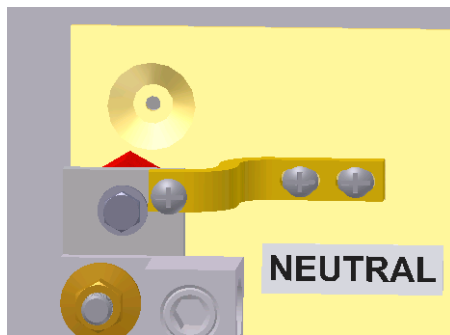

2. Apply the Service Disconnect label supplied with the ATS to the front of the door under the circuit breaker toggle



4 GENERAL DESCRIPTION

TS 910/920 Automatic Transfer Switches employ a power contactor switching unit with a microprocessor based controller to automatically start a generator and transfer system load to a generator supply in the event of a utility supply failure. System load is automatically re-transferred back to the utility supply following restoration of the utility power source to within normal operating limits. All load transfer sequences are Open Transition (i.e. break-before-make) utilizing an in-phase transfer detection control sequence.

The TS 910/920 series transfer switches use a type TSC 9 microprocessor based controller. All necessary control functions for fully automatic operation are provided by the TSC 9 transfer controller. The TSC 9 controller is mounted inside the transfer switch enclosure and operating status is provided via LED indicators that are visible through a front panel opening on NEMA 1 rated enclosures. For detailed information on the TSC 9 Transfer Switch controller, refer to [SECTION 19](#) of this manual. On TS 920 Series Transfer Switches, an additional door mounted operator interface panel (i.e. BHP) is provided.

The standard TS 910/920 series Automatic Transfer Switch is rated for 100% system load and is suitable for control of motors, electric discharge lamps, tungsten filament lamps, and electric heating equipment where the sum of motor full-load ampere ratings and the ampere ratings of other loads do not exceed the ampere rating of the switch and the tungsten load does not exceed 30 percent of the switch rating.

Service Entrance Rated TS 910/920 Automatic Transfer Switch models are supplied with a utility supply circuit breaker with over current protection. Refer to [SECTION 18](#) of this manual for detailed information on over current protection.

4.1 PRODUCT MODEL CODE

The type of TS 910/920 series transfer switch supplied is identified by way of a 11 digit product code which appears on the equipment rating plate, or model, on the inside of the door of the transfer switch.

Model Number	Amperage	Voltage*	Standard ATS	Service Entrance Rated ATS	2 Pole	3 Pole	3 wire/4 wire with Neutral	50/60Hz	Nema 1 Enclosure
TS912A0100A	100A	120/240V	●		●		●	●	●
TS912A0100B	100A	120/240V		●	●		●	●	●
TS912A0200A	200A	120/240V	●		●		●	●	●
TS912A0200B	200A	120/240V		●	●		●	●	●
TS912A0400A	400A	120/240V	●		●		●	●	●
TS912A0400B	400A	120/240V		●	●		●	●	●
TS913A0100A	100A	120/240V	●			●	●	●	●
TS913A0100B	100A	120/240V		●		●	●	●	●
TS913A0200A	200A	120/240V	●			●	●	●	●
TS913A0200B	200A	120/240V		●		●	●	●	●
TS913A0400A	400A	120/240V	●			●	●	●	●
TS913A0400B	400A	120/240V		●		●	●	●	●
TS923A0100A	100A	120/240V	●			●	●	●	●
TS923A0100B	100A	120/240V		●		●	●	●	●
TS923A0200A	200A	120/240V	●			●	●	●	●
TS923A0200B	200A	120/240V		●		●	●	●	●
TS923A0400A	400A	120/240V	●			●	●	●	●
TS923A0400B	400A	120/240V		●		●	●	●	●

* Configurable voltage to 208V or 220V

4.2 TS 910/920 OPTIONAL ACCESSORIES

The following optional accessories may be ordered as field installable kits.

Model Code	Description
TS910 - HTR	Enclosure Heater, 120VAC Fused, supplied from ATS Load Bus
TS910 - SPD1PH	Surge Protective Device, Single Phase Class 1, 120/240V
TS910 - SPD3PH	Surge Protective Device, 3 Phase Class 1, 120/208V
TS910 - KWLS1PH2	kW Load Shed Control output contact, Single Phase, One Stage, 0-200A Current Transformers connected to ATS Load Bus
TS910 - KWLS1PH4	kW Load Shed Control output contact, Single Phase, One Stage, 0-400A Current Transformers connected to ATS Load Bus
TS910 - KWLS3PH2	kW Load Shed Control output contact, 3 Phase, One Stage, 0-200A Current Transformers connected to ATS Load Bus
TS910 - KWLS3PH4	kW Load Shed Control output contact, 3 Phase, One Stage, 0-400A Current Transformers connected to ATS Load Bus
TS910 - WMS**	Wireless Remote Alarm Messaging Module
TS910 - N3R100A TS910 - N3R100B TS910 - N3R200A TS910 - N3R200B TS913 - N3R200A TS913 - N3R200B TS910 - N3R400A TS910 - N3R400B	NEMA 3R Door, External Door Mountable to NEMA 1 ATS Enclosure (Specify matching ATS model number)
TS910 - UGI	Universal Generator Interface Start Kit

**Wireless option is not available on TS 920 series ATS

Additional information on TS 910/920 optional accessories can be obtained from our Website (www.thomsonps.com).

4.3 TYPICAL COMMISSIONING PROCEDURES

CAUTION

Commissioning procedures must be performed by qualified personnel only.

NOTE: The Typical Automatic Transfer Switch Commissioning Procedures Model Series TS 910/920, attached as Appendix A, is provided for general information only pertaining to typical site installations and applications. Contact Thomson Power Systems for further information as may be required.

5 GENERAL THEORY OF OPERATION

5.1 AUTOMATIC SEQUENCE OF OPERATION

NOTE: Time delays indicated below are factory default settings only. Refer to SECTION 19.15 of this manual for alternate time delay settings available on TSC 9 Controller	
UTILITY POWER FAIL	When voltage drops on any phase of the utility supply below 70% of rated voltage, a generator start sequence will be initiated.
GEN START	The generator will start following expiry of the 3 second <i>Gen Start</i> timer.
GEN WARMUP	A generator warmup period will be initiated once the generator starts and reaches 80% rated voltage and 90% rated frequency.
TRANSFER TO GEN	The load will transfer to the generator supply following expiry of the 10 second <i>Gen Warmup</i> timer.
LOAD SHED ACTIVATE	All non-essential loads connected to Load Shed control circuit will be de-energized once generator transfers on load (If kW Load Shed option is installed, refer to SECTION 19.16 of this manual for further details).
UTILITY POWER RETURN	When utility power is restored to above 80% rated voltage on all phases, a utility power return sequence will be initiated.
TRANSFER TO UTILITY	The load will transfer from generator to utility power following expiry of the 120 second <i>Utility Return</i> timer, provided both generator and utility voltages are in-phase at time of transfer.
LOAD SHED RESET	All non-essential loads connected to Load Shed control circuit will be re-energized once load transfers to utility power.
GEN COOLDOWN	The generator will automatically stop following expiry of the two-minute <i>Generator Cooldown</i> timer.

5.2 SERVICE ENTRANCE AUTOMATIC TRANSFER SWITCH OPERATION

5.2.1 OVER CURRENT TRIP

Should the utility breaker trip open due to an over current condition, TSC 9 transfer controller will initiate an engine start signal and will permit transfer of the load to the generator supply. The utility source will be locked out and the load will remain on the generator supply until the Utility Service Entrance breaker is manually reset.

5.2.2 SERVICE DISCONNECT PROCEDURE

To initiate a Utility Supply Service Disconnect, follow procedure shown below:

- 5.2.2.1** TURN OFF GEN STARTING CONTROL: At the generator set, turn it's automatic starting control to OFF position to prevent generator set from automatically starting when the Utility Service disconnect breaker is opened.
- 5.2.2.2** LOCK OPEN GENERATOR CIRCUIT BREAKER: At the generator set, Open its main generator output power circuit breaker. Attach safety lockout padlock to the circuit breaker to prevent unauthorized change in operating condition.

WARNING

Failure to lock open the main generator output circuit breaker may result in serious personal injury or death due to electrical shock.

- 5.2.2.3** LOCK OPEN UTILITY SERVICE DISCONNECT BREAKER: At the transfer switch, Open the Utility Service disconnect circuit breaker. Attach safety lockout padlock directly onto the Service Disconnect Utility circuit breaker toggle as provided to prevent unauthorized change in operating condition.

NOTE

On NEMA 3R rated Transfer Switches, A door locking Padlock hasp is also provided in cases where the padlock does not fit behind the NEMA 3R door when closed.

WARNING

Failure to lock open the Utility Service disconnect circuit breaker may result in serious personal injury or death due to electrical shock.

DANGER

**Arc Flash and Shock Hazard. Will cause severe injury or death.
Do not open equipment until ALL power sources are disconnected
This equipment must be installed and serviced only by qualified electrical
personnel utilizing safe work practices and appropriate Personal Protective
Equipment (PPE). Failure to do so may cause personal injury or death**

5.2.3 RETURN FROM SERVICE DISCONNECT MODE

To return the system back to automatic operation following a Service Disconnect mode, follow procedure shown below:

- 5.2.3.1 CLOSE ATS ENCLOSURE DOOR:** Prior to Load re-energization, ensure the transfer switch enclosure door/front cover is adequately closed with all provided fasteners.
- 5.2.3.2 CLOSE UTILITY SERVICE DISCONNECT BREAKER:** To re-energize the load, remove the padlock(s) from the Utility Service Disconnect Circuit Breaker and or ATS door, and move the circuit breaker to the Closed position. The Load will be re-energized and the transfer switch will remain in the utility supply position.
- 5.2.3.3 CLOSE GENERATOR CIRCUIT BREAKER:** At the generator set, re-close the main generator output power circuit breaker.
- 5.2.3.4 RE-ENABLE AUTOMATIC GEN STARTING CONTROL:** At the generator set, turn its automatic starting control back to the AUTOMATIC position to return the system back to fully automatic operation.

6 OVER CURRENT PROTECTION

6.1 **STANDARD TS 910/920 AUTOMATIC TRANSFER SWITCH**

The standard TS 910/920 Automatic Transfer Switch does not contain any integral over current protection and requires upstream over current protection devices for both Utility and Generator sources. The standard TS 910/920 is suitable for control of motors, electric discharge lamps, tungsten filament lamps, and electric heating equipment where the sum of the motor full-load ampere rating and the ampere rating of the other loads do not exceed the ampere rating of the switch and the tungsten load does not exceed 30 percent of the switch rating. The Standard TS 910/920 is rated for 100% continuous loading subject to load content described above and can withstand a maximum short circuit fault current as noted in [SECTION 18](#) of this manual. The standard TS 910/920 transfer switch model without integral over current protection is identified in the product model code. Refer to [SECTION 4.1](#) of this manual for further details on model coding.

6.2 **SERVICE ENTRANCE RATED TS 910/920 AUTOMATIC TRANSFER SWITCH**

Service Entrance rated TS 910/920 transfer switch models contain integral over current protection for the Utility source as standard. Service Entrance rated TS 910/920 transfer switches do not contain any integral over current protection for the generator source and requires upstream generator source over current protection. Service Entrance rated TS 910/920 is suitable for control of motors, electric discharge lamps, tungsten filament lamps, and electric heating equipment where the sum of the motor full-load ampere rating and the ampere rating of the other loads do not exceed the ampere rating of the switch and the tungsten load does not exceed 30 percent of the switch rating. The Service Entrance rated TS 910/920 is rated for 80% maximum continuous loading subject to load content described above and can interrupt/withstand a maximum short circuit fault current as noted in [SECTION 18](#) of this manual. Over current protection provided on the utility source is non-adjustable thermal-magnetic type.

7 GENERAL NOTES ON SERVICING TRANSFER SWITCH MECHANISM

DANGER

Arc Flash and Shock Hazard. Will cause severe injury or death.

Do not open equipment until ALL power sources are disconnected

This equipment must be installed and serviced only by qualified electrical personnel utilizing safe work practices and appropriate Personal Protective Equipment (PPE). Failure to do so may cause personal injury or death

Only qualified personnel should undertake Service work. Failure to correctly maintain an automatic transfer switch may present a hazard to life and equipment. Full operational testing must be done prior to placing a transfer switch in service subsequent to any maintenance or repair. Any service work involving electrical components requires high-potential testing to ensure that required insulation levels have been maintained.

When performing any service work on the transfer mechanism, it is imperative that the following be observed:

To maintain mechanical integrity, ensure that:

- All fasteners are adequately tightened
- The operating shaft is not damaged or bent, and that all bearing points operate freely

To maintain electrical integrity, ensure that:

- All electrical connections, especially power connections, are clean and adequately tightened. Corroded or loose power connections will cause destructive heating, and may cause premature tripping
- All insulating devices are in place and in good condition
- No moisture or other contamination is present
- Electrical conductors are adequately secured away from moving parts

To maintain operational integrity, ensure that:

- All control devices are in good condition and correctly calibrated
- All control devices are adequately secured in their plug-in fixtures

8 TRANSFER SWITCH MECHANISM OPERATION

The transfer mechanism is a power contactor assembly. The transfer switch mechanism has only two possible positions: Utility contacts closed or Generator contacts closed. There is no neutral position.

8.1 AUTOMATIC OPERATION

During automatic operation, the TSC 9 controller issues pulsed control signals to each of the power contactor solenoids for the utility and generator supply. Two solenoids are utilized, one

for utility supply, one for the generator supply. The two solenoids are electrically interlocked and are intermittent duty rated only (i.e. they cannot be continuously energized otherwise damage will result).

8.2 MANUAL OPERATION

The transfer switch maybe operated manually for maintenance or emergency operation conditions provided both Utility and Generator supplies are de-energized prior to manual operation.



DANGER

HAZARD OF ELECTRICAL SHOCK, EXPLOSION, OR ARC FLASH

This equipment must be serviced only by qualified electrical personnel utilizing safe work practices and appropriate Personal Protective Equipment (PPE). Many components of this equipment operate at line voltage. DO NOT TOUCH. Use only electrically isolated tools.

Install and close all covers before applying power to this equipment

Do not open covers to equipment until ALL power sources are disconnected

Failure to do so may cause personal injury or death

Once both Utility and Generator supplies are de-energized the following procedure can be used to operate the Transfer Switch manually.

- a) Up-plug the TSC 9 controller isolation plug (J4) to prevent automatic operation.
- b) Open ATS enclosure and locate Manual Operation Handle provided with the transfer switch (see photos below)



100A/200A ATS Handle



400A ATS Handle

- c) Insert manual handles onto the transfer switch mechanism at locations shown in the following diagrams.

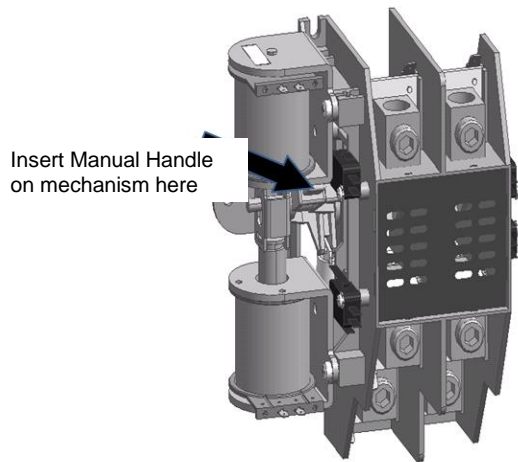

100A/200A Contactor Mechanism

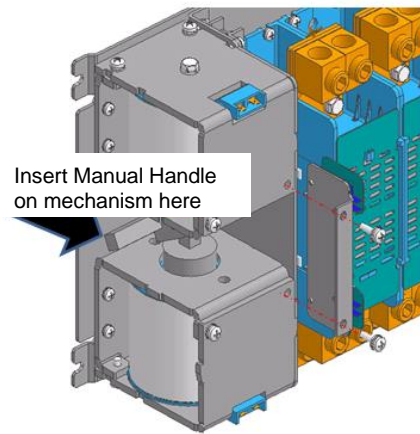

400A Contactor Mechanism

- d) To manually operate mechanism to the utility supply position, rotate handle upwards. Do not over-torque handle once position has been attained.
- e) To manually operate mechanism to the generator supply position, rotate handle downwards. Do not over-torque handle once position has been attained.
- f) Once ATS is manually operated to desired position, re-install enclosure cover, then re-energize supply sources to re-energize the load.

9 RECOMMENDED MAINTENANCE

DANGER

**Arc Flash and Shock Hazard. Will cause severe injury or death.
Do not open equipment until ALL power sources are disconnected
This equipment must be installed and serviced only by qualified electrical
personnel utilizing safe work practices and appropriate Personal Protective
Equipment (PPE). Failure to do so may cause personal injury or death**

- 9.1.1 Do not perform dielectric tests on the equipment with the control components in the circuit.
- 9.1.2 Check if control components are tight in sockets.
- 9.1.3 Periodically inspect all terminals (load, line and control) for tightness. Re-torque all bolts, nuts and other hardware. Clean or replace any contact surfaces, which are dirty, corroded or pitted.
- 9.1.4 Transfer switches should be in a clean, dry and moderately warm location. If signs of moisture are present, dry and clean transfer switch. If there is corrosion, try to clean it off. If cleaning is unsuitable, replace the corroded parts. Should dust and/or debris gather on the transfer switch, brush, vacuum, or wipe clean. Do not blow dirt into power switching devices.
- 9.1.5 Test the transfer switch operation. While the unit is exercising, check for freedom of movement, hidden dirt, corrosion or any excessive wear on the mechanical operating parts.
- 9.1.6 Verify all settings on the TSC 9 controller as per the TSC 9 component calibration label inside the transfer switch enclosure.

10 FRONT INTERIOR VIEW (100A STANDARD ATS) (3 Pole Model shown)

TSC 9
CONTROLLER

UTILITY SUPPLY

TRANSFER
MECHANISM

GEN SUPPLY
(TOP LUGS)

CUSTOMER
CONTROL
CONNECTIONS:

- GEN START
- LOAD SHED
- ALARM
- REMOTE TEST

LOAD
(BOTTOM LUGS)

ENCLOSURE
MOUNTING
HOLES (TYP 4)

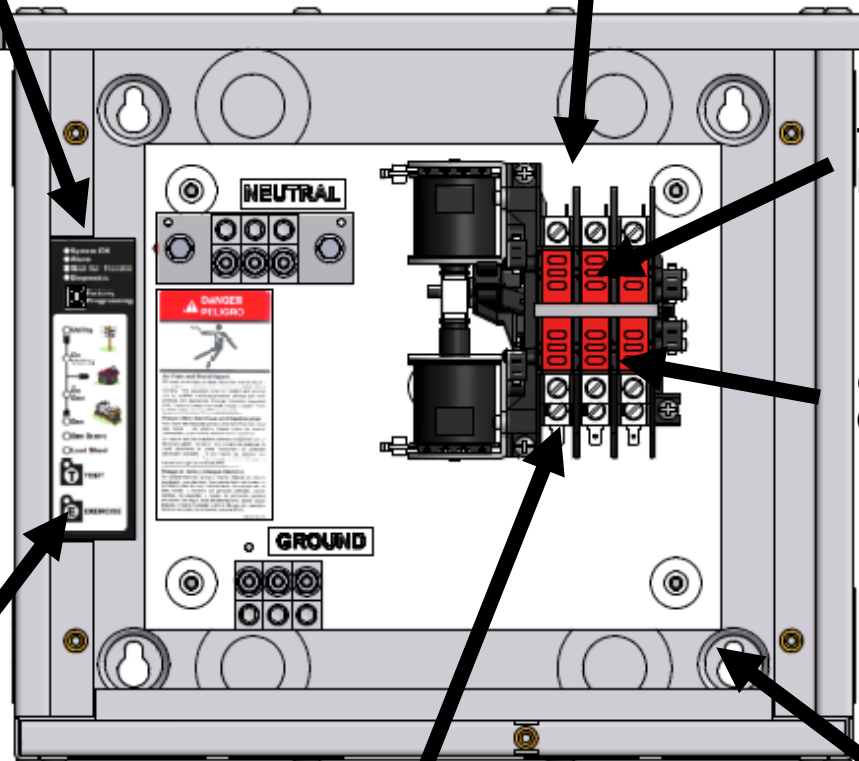

11 FRONT INTERIOR VIEW (100A SERVICE ENTRANCE ATS)

(3 Pole Model shown)

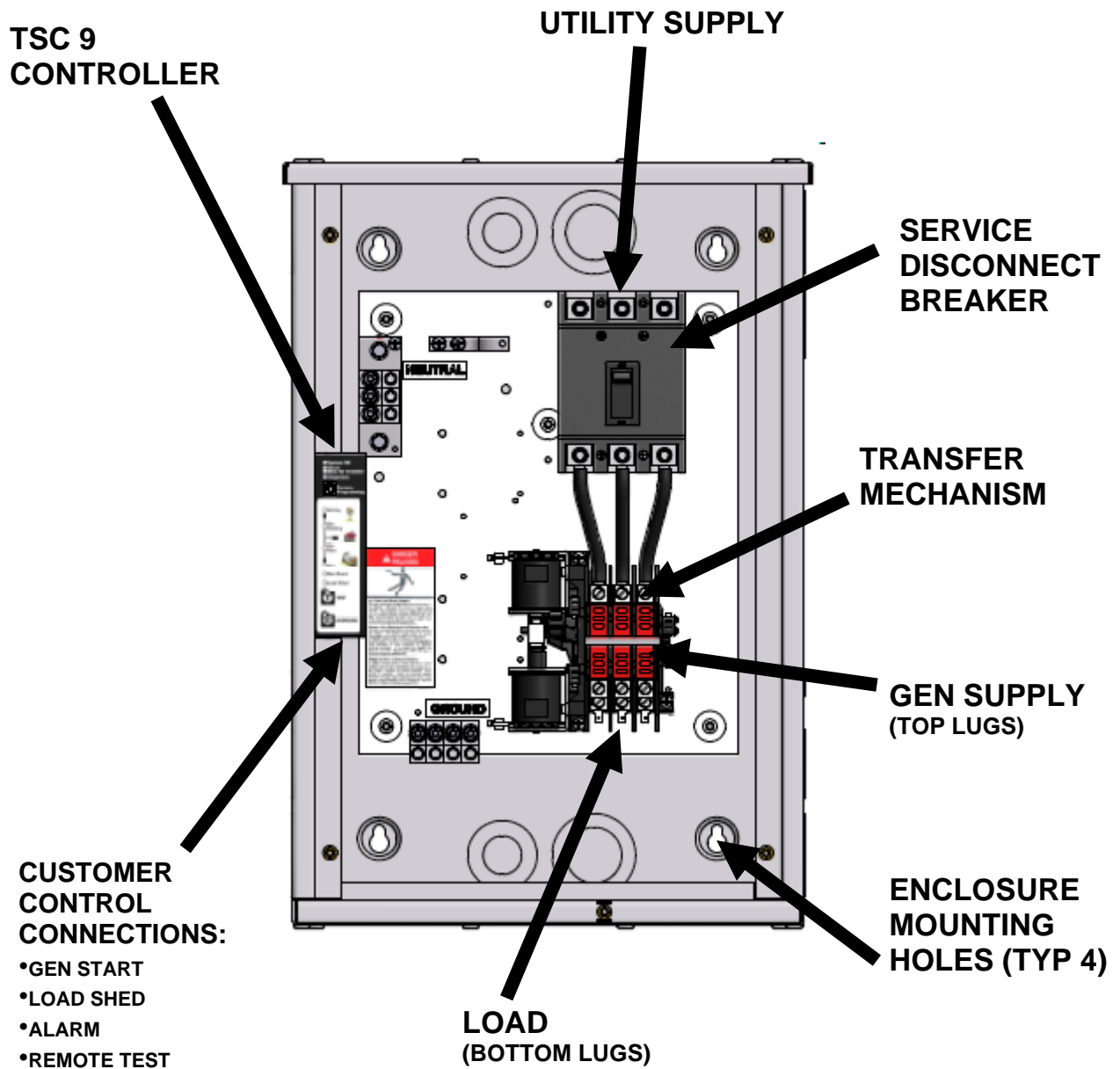

12 FRONT INTERIOR VIEW (200A STANDARD ATS) (3 Pole Model shown)

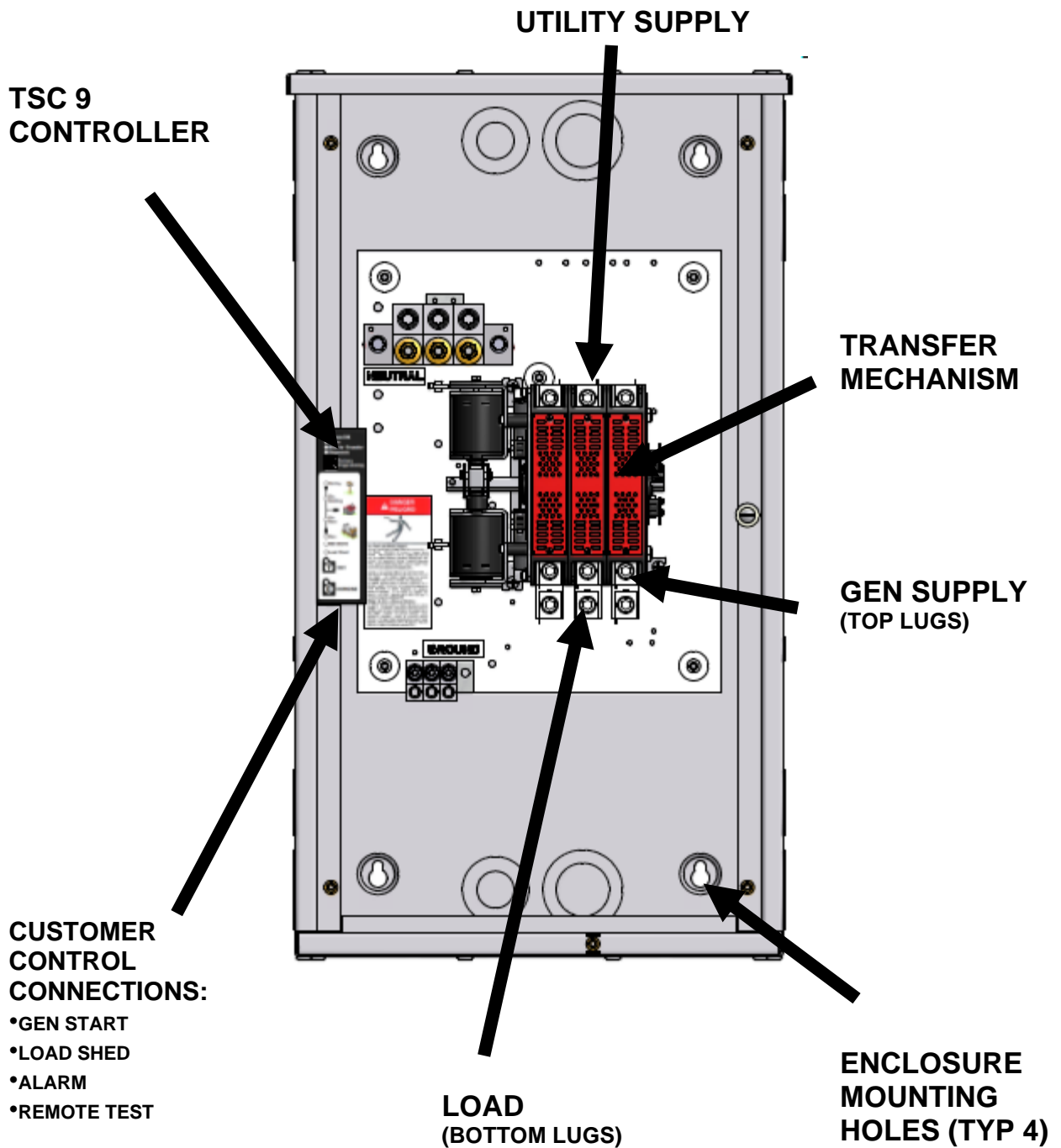

13 FRONT INTERIOR VIEW (200A SERVICE ENTRANCE ATS)

(3 Pole Model shown)

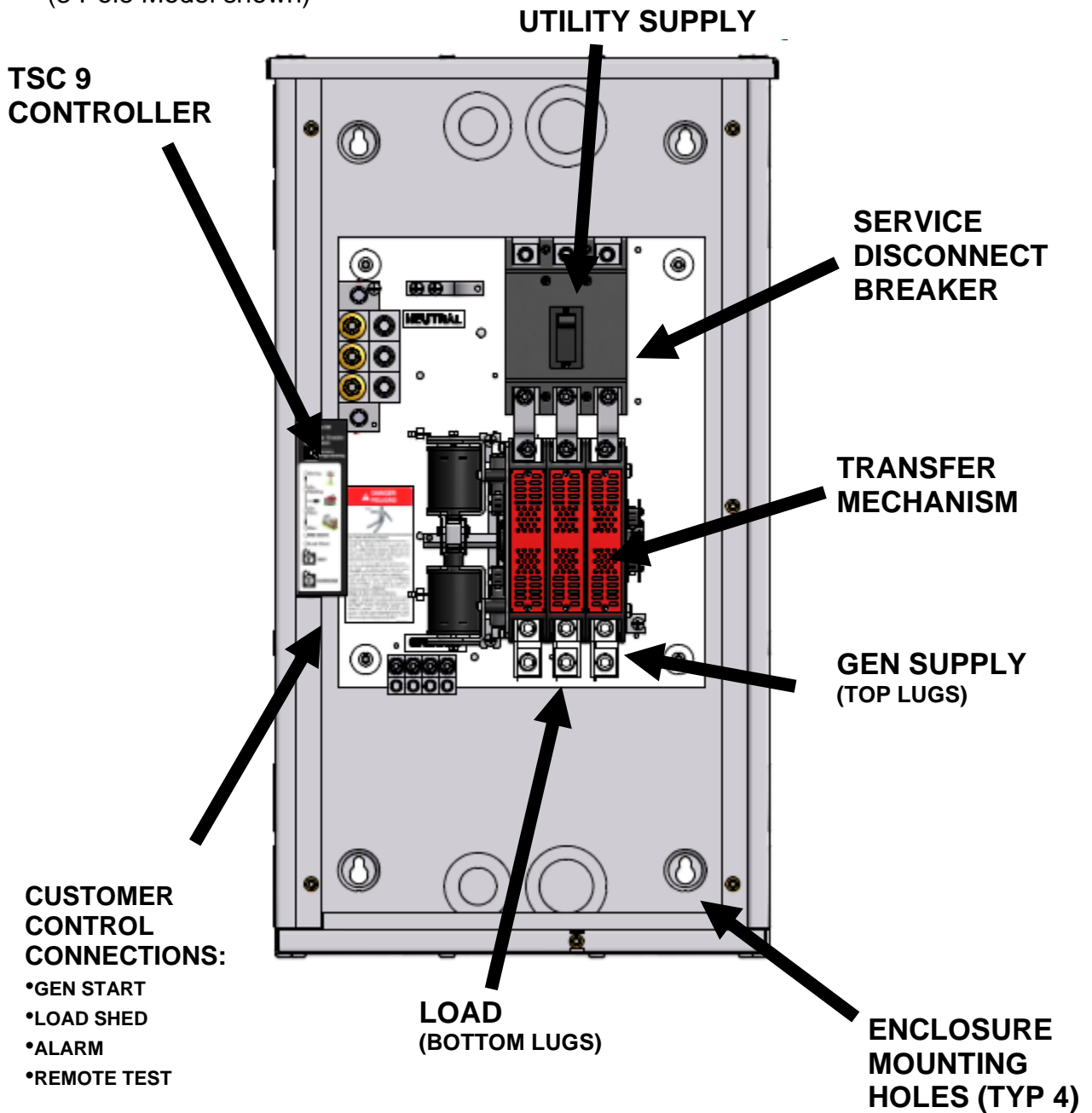

14 FRONT INTERIOR VIEW (400A STANDARD ATS)

(3 Pole Model shown)

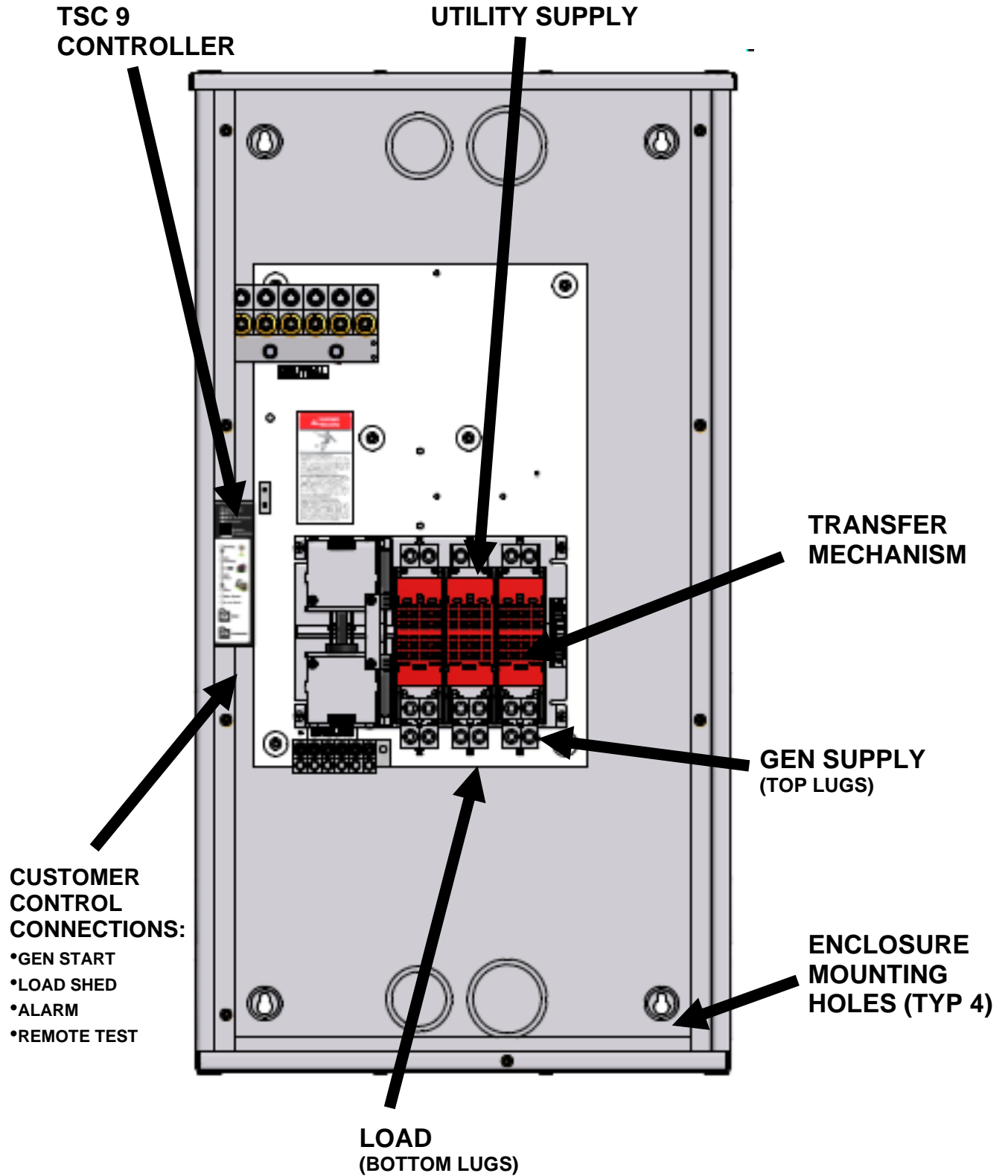

15 FRONT INTERIOR VIEW (400A SERVICE ENTRANCE ATS)

(3 Pole Model shown)

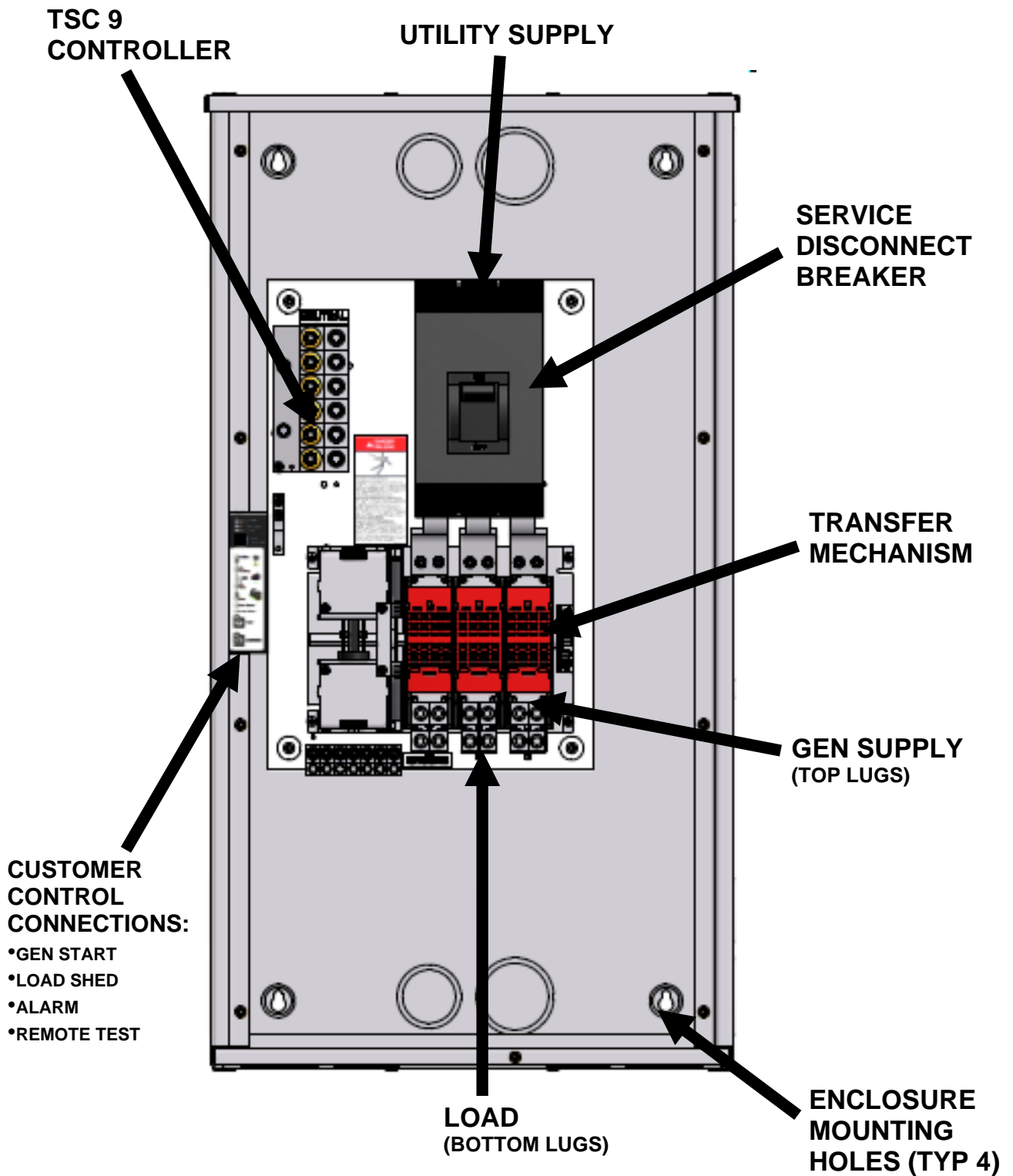

16 ENCLOSURE DIMENSIONS

MODEL	ATS TYPE	POLES	MAX VOLTAGE	AMPERAGE	DIMENSIONS ¹			SHIPPING WEIGHT LBS
					HEIGHT INCHES	WIDTH INCHES	DEPTH INCHES	
TS912A0100A	STANDARD	2	240V	100A	16 1/8"	18 7/8"	8 1/4"	20 lbs
TS912A0100B	SERVICE ENTRANCE	2	240V	100A	27 1/8"	18 7/8"	8 1/4"	30 lbs
TS912A0200A	STANDARD	2	240V	200A	27 1/8"	18 7/8"	8 1/4"	30 lbs
TS912A0200B	SERVICE ENTRANCE	2	240V	200A	32 7/8"	18 7/8"	8 1/4"	35 lbs
TS912A0400A	STANDARD	2	240V	400A	45 1/8"	24 7/8"	11"	70 lbs
TS912A0400B	SERVICE ENTRANCE	2	240V	400A	45 1/8"	24 7/8"	11"	80 lbs
TS913A0100A	STANDARD	3	240V	100A	16 1/8"	18 7/8"	8 1/4"	25 lbs
TS913A0100B	SERVICE ENTRANCE	3	240V	100A	27 1/8"	18 7/8"	8 1/4"	35 lbs
TS913A0200A	STANDARD	3	240V	200A	32 7/8"	18 7/8"	8 1/4"	35 lbs
TS913A0200B	SERVICE ENTRANCE	3	240V	200A	32 7/8"	18 7/8"	8 1/4"	40 lbs
TS913A0400A	STANDARD	3	240V	400A	45 1/8"	24 7/8"	11"	80 lbs
TS913A0400B	SERVICE ENTRANCE	3	240V	400A	45 1/8"	24 7/8"	11"	90 lbs
TS923A0100A	STANDARD	3	240V	100A	16 1/8"	18 7/8"	8 1/4"	20 lbs
TS923A0100B	SERVICE ENTRANCE	3	240V	100A	27 1/8"	18 7/8"	8 1/4"	30 lbs
TS923A0200A	STANDARD	3	240V	200A	32 7/8"	18 7/8"	8 1/4"	35 lbs
TS923A0200B	SERVICE ENTRANCE	3	240V	200A	32 7/8"	18 7/8"	8 1/4"	70 lbs
TS923A0400A	STANDARD	3	240V	400A	45 1/8"	24 7/8"	11"	90 lbs
TS923A0400B	SERVICE ENTRANCE	3	240V	400A	45 1/8"	24 7/8"	11"	90 lbs

1. Enclosure Dimensions are for reference (DO NOT USE FOR CONSTRUCTION.)
2. All cable connections are suitable for Copper or Aluminum.

17 POWER CONDUCTOR INSTALLATION

The transfer switch is provided with power cable lugs for line, load and neutral block as per sizes indicated in the following table below. All Power cables are to be installed and torqued on the lugs per values indicated in the table below.



WARNING

Failure to properly install and adequately tighten power cable connections can result in equipment malfunction and/or damage.

MODEL	AMP	UTILITY		GENERATOR		NEUTRAL		GROUND	
		Cable	Lug	Cable	Lug	Cable	Lug	Cable	Lug
TS912A0100A	100A	#3-1/0	50 in*Ibs	#3-1/0	50	#12-1/0	50 in*Ibs	#12-1/0	50 in*Ibs
TS912A0100B	100A	#3-300 mcm	250 in * Ibs	#3-1/0	50	#12-1/0	50 in*Ibs	#12-1/0	50 in*Ibs
TS912A0200A	200A	3/0-250mcm	150 in*Ibs	3/0-250mcm	150 in*Ibs	#6-250mcm,	275 in*Ibs	#12-1/0	50 in*Ibs
TS912A0200B	200A	3/0-250mcm	250 in * Ibs	3/0-250mcm	150 in*Ibs	#6-250mcm,	275 in*Ibs	#12-1/0	50 in*Ibs
TS912A0400A	400A	3/0-250mcm	150 in*Ibs	3/0-250mcm	150 in*Ibs	2c, 1/0-250mcm	275 in*Ibs	#3-2/0	50 in*Ibs
TS912A0400B	400A	3/0-250mcm	375 in*Ibs	3/0-250mcm	150 in*Ibs	2c, 1/0-250mcm	275 in*Ibs	#3-2/0	50 in*Ibs
TS913A0100A	100A	#3-1/0	50 in*Ibs	#3-1/0	50	#12-1/0	50 in*Ibs	#12-1/0	50 in*Ibs
TS913A0100B	100A	#3-300 mcm	250 in * Ibs	#3-1/0	50	#12-1/0	50 in*Ibs	#12-1/0	50 in*Ibs
TS913A0200A	200A	3/0-250mcm	150 in*Ibs	3/0-250mcm	150 in*Ibs	#6-250mcm,	275 in*Ibs	#12-1/0	50 in*Ibs
TS913A0200B	200A	3/0-250mcm	250 in * Ibs	3/0-250mcm	150 in*Ibs	#6-250mcm,	275 in*Ibs	#12-1/0	50 in*Ibs
TS913A0400A	400A	3/0-250mcm	150 in*Ibs	3/0-250mcm	150 in*Ibs	2c, 1/0-250mcm	275 in*Ibs	#3-2/0	50 in*Ibs
TS913A0400B	400A	3/0-250mcm	375 in*Ibs	3/0-250mcm	150 in*Ibs	2c, 1/0-250mcm	275 in*Ibs	#3-2/0	50 in*Ibs
TS923A0100A	100A	#3-1/0	50 in*Ibs	#3-1/0	50	#12-1/0	50 in*Ibs	#12-1/0	50 in*Ibs
TS923A0100B	100A	#3-300 mcm	250 in * Ibs	#3-1/0	50	#12-1/0	50 in*Ibs	#12-1/0	50 in*Ibs
TS923A0200A	200A	3/0-250mcm	150 in*Ibs	3/0-250mcm	150 in*Ibs	#6-250mcm,	275 in*Ibs	#12-1/0	50 in*Ibs
TS923A0200B	200A	3/0-250mcm	250 in * Ibs	3/0-250mcm	150 in*Ibs	#6-250mcm,	275 in*Ibs	#12-1/0	50 in*Ibs
TS923A0400A	400A	3/0-250mcm	150 in*Ibs	3/0-250mcm	150 in*Ibs	2c, 1/0-250mcm	275 in*Ibs	#3-2/0	50 in*Ibs
TS923A0400B	400A	3/0-250mcm	375 in*Ibs	3/0-250mcm	150 in*Ibs	2c, 1/0-250mcm	275 in*Ibs	#3-2/0	50 in*Ibs



18 REQUIREMENTS FOR UPSTREAM CIRCUIT PROTECTIVE DEVICES

Standard TS 910/920 Series transfer switches require upstream circuit breakers to be installed on the utility and generator supply to provide adequate overload and short circuit over current protection for the transfer switch and connected downstream loads. The transfer switch can be used on electrical systems delivering a maximum of short circuit current as indicated in Table 1 & Table 2 below provided specific types of circuit breakers (i.e. manufacturer, model and size) are utilized. Specific circuit breaker types are listed in the following Tables based on transfer switch amperage size.

Service Entrance rated TS 910/920 Series transfer switches require upstream circuit breakers to be installed only the generator supply to provide adequate overload and short circuit over current protection for the transfer switch and connected downstream loads.

For other circuit breaker types and sizes not listed, contact Thomson Power Systems.

MODEL	ATS TYPE	POLES	MAX VOLTAGE	AMPERAGE	SHORT CIRCUIT CURRENT ¹
TS912A0100A	STANDARD	2	240V	100A	10kA
TS912A0100B	SERVICE ENTRANCE	2	240V	100A	10kA
TS912A0200A	STANDARD	2	240V	200A	10kA
TS912A0200B	SERVICE ENTRANCE	2	240V	200A	10kA
TS912A0400A	STANDARD	2	240V	400A	50kA ²
TS912A0400B	SERVICE ENTRANCE	2	240V	400A	25kA
TS913A0100A	STANDARD	3	240V	100A	22kA ²
TS913A0100B	SERVICE ENTRANCE	3	240V	100A	10kA
TS913A0200A	STANDARD	3	240V	200A	25kA ²
TS913A0200B	SERVICE ENTRANCE	3	240V	200A	10kA
TS913A0400A	STANDARD	3	240V	400A	50kA ²
TS913A0400B	SERVICE ENTRANCE	3	240V	400A	25kA

¹ AMPS RMS Symmetrical

² When protected by a specific upstream circuit breaker per *SECTION 18*

TABLE 1 TS 910 Withstand/Interrupting Current Ratings



MODEL	ATS TYPE	POLES	MAX VOLTAGE	AMPERAGE	SHORT CIRCUIT CURRENT ¹
TS923A0100A	STANDARD	3	240V	100A	22kA ²
TS923A0100B	SERVICE ENTRANCE	3	240V	100A	10kA
TS923A0200A	STANDARD	3	240V	200A	25kA ²
TS923A0200B	SERVICE ENTRANCE	3	240V	200A	10kA
TS913A0400A	STANDARD	3	240V	400A	50kA ²
TS923A0400B	SERVICE ENTRANCE	3	240V	400A	25kA

¹ AMPS RMS Symmetrical

² When protected by a specific upstream circuit breaker per SECTION 18

TABLE 2 TS 920 Withstand/Interrupting Current Ratings

18.1 100A, 2P NON-SERVICE ENTRANCE ATS UPSTREAM CIRCUIT PROTECTIVE DEVICES

SHORT-CIRCUIT WITHSTAND/CLOSING RATINGS		
When protected by a circuit breaker, this transfer switch is suitable for use in a circuit capable of delivering the short-circuit current for the maximum time duration and voltage marked below.		
The circuit breaker must include an instantaneous trip response unless the available short-circuit current is less than or equal to the short time rating of the transfer switch and the circuit breaker includes a short-time trip response.		
The maximum clearing time of the instantaneous trip response must be less than or equal to the time duration shown for the marked short-circuit current.		
When protected by a circuit breaker with a short-time trip response, the short-time response of the circuit breaker must be coordinated with the short-time rating of the transfer switch as marked below.		
SHORT CIRCUIT CURRENT	VOLTAGE	TIME DURATION
(RMS SYMMETRICAL AMPERES x 1000)	(VOLTS AC, MAXIMUM)	(SEC, MAXIMUM)
10	240	0.025
SHORT TIME CURRENT RATINGS		
THIS TRANSFER SWITCH DOES NOT INCLUDE SHORT-TIME CURRENT RATINGS		

SPECIFIC CIRCUIT BREAKER MANUFACTURER AND TYPE				
When protected by a circuit breaker of the specific manufacturer, type and ampere rating as marked below, this transfer switch is suitable for use in circuits capable of delivering the short-circuit current at the maximum voltage marked.				
SHORT CIRCUIT CURRENT	VOLTAGE	MANUFACTURER	TYPE	RATING
(RMS SYMMETRICAL AMPERES x 1000)	(VOLTS AC, MAXIMUM)			(AMPERES)
22	240	Eaton / Cutler Hammer	QCHW	125A
		Eaton / Cutler Hammer	FDC	150A
		Siemens	HED4	125A
		Siemens	ED4,ED6	125A
		Siemens	HED4,HED6	125A
		Siemens	CED6	125A
SHORT TIME CURRENT RATINGS				
THIS TRANSFER SWITCH DOES NOT INCLUDE SHORT-TIME CURRENT RATINGS				

NOTE: 100A Service Entrance Rated TS 910/920 Transfer switches have an Interrupting Rating on the Utility supply of 10,000 Amps (RMS symmetrical).

18.2 100A, 3P NON-SERVICE ENTRANCE ATS UPSTREAM CIRCUIT PROTECTIVE DEVICES

SHORT-CIRCUIT WITHSTAND/CLOSING RATINGS		
When protected by a circuit breaker, this transfer switch is suitable for use in a circuit capable of delivering the short-circuit current for the maximum time duration and voltage marked below.		
The circuit breaker must include an instantaneous trip response unless the available short-circuit current is less than or equal to the short time rating of the transfer switch and the circuit breaker includes a short-time trip response.		
The maximum clearing time of the instantaneous trip response must be less than or equal to the time duration shown for the marked short-circuit current.		
When protected by a circuit breaker with a short-time trip response, the short-time response of the circuit breaker must be coordinated with the short-time rating of the transfer switch as marked below.		
SHORT CIRCUIT CURRENT	VOLTAGE	TIME DURATION
(RMS SYMMETRICAL AMPERES x 1000)	(VOLTS AC, MAXIMUM)	(SEC, MAXIMUM)
10	240	0.025
SHORT TIME CURRENT RATINGS		
THIS TRANSFER SWITCH DOES NOT INCLUDE SHORT-TIME CURRENT RATINGS		



SPECIFIC CIRCUIT BREAKER MANUFACTURER AND TYPE				
When protected by a circuit breaker of the specific manufacturer, type and ampere rating as marked below, this transfer switch is suitable for use in circuits capable of delivering the short-circuit current at the maximum voltage marked.				
SHORT CIRCUIT CURRENT	VOLTAGE	MANUFACTURER	TYPE	RATING
(RMS SYMMETRICAL AMPERES x 1000)	(VOLTS AC, MAXIMUM)			(AMPERES)
22	240	Siemens	ED4,ED6	125A
		Siemens	CED6	125A
		Siemens	HED4,HHED6,HED6	125A
		Siemens	NGG	125A
		Siemens	NGB	125A
		Siemens	QPH,QPPH	125A
		Siemens	HPQ,HQPP	125A
		Siemens	BLH	125A
		Siemens	NDG	150A
		Siemens	HDG	150A
		Siemens	LDG	150A
		Siemens	QJH2	225A
		Siemens	QJ2H	225A
		Siemens	HQJ2	225A
		Siemens	HQJ2-H	225A
		Schneider/Square D	EGB	125A
		Schneider/Square D	EDB	125A
		Schneider/Square D	EJB	125A
		Schneider/Square D	QOB-VH	150A
		Schneider/Square D	Q2-H	225A
		Schneider/Square D	QD	250A
		Schneider/Square D	QG	250A
		Schneider/Square D	QJ	250A
		Eaton/Cutler Hammer	ED	225A
		Eaton/Cutler Hammer	EDH	225A
		Eaton/Cutler Hammer	EDC	225A
		Eaton/Cutler Hammer	EDB	225A
		Eaton/Cutler Hammer	EDS	225A
		Eaton/Cutler Hammer	FD	225A
		Eaton/Cutler Hammer	HFD	225A
		Eaton/Cutler Hammer	FDC	225A
		Eaton/Cutler Hammer	CAH	225A
		Eaton/Cutler Hammer	HCA	225A
		General Electric	THQD	225A
General Electric	THLC2	225A		

SHORT TIME CURRENT RATINGSFDC

THIS TRANSFER SWITCH DOES NOT INCLUDE SHORT-TIME CURRENT RATINGS

NOTE: 100A Service Entrance Rated TS 910/920 Transfer switches have an Interrupting Rating on the Utility supply of 10,000 Amps (RMS symmetrical).



18.3 200A, 2P NON-SERVICE ENTRANCE ATS UPSTREAM CIRCUIT PROTECTIVE DEVICES

SHORT-CIRCUIT WITHSTAND/CLOSING RATINGS		
When protected by a circuit breaker, this transfer switch is suitable for use in a circuit capable of delivering the short-circuit current for the maximum time duration and voltage marked below.		
The circuit breaker must include an instantaneous trip response unless the available short-circuit current is less than or equal to the short time rating of the transfer switch and the circuit breaker includes a short-time trip response.		
The maximum clearing time of the instantaneous trip response must be less than or equal to the time duration shown for the marked short-circuit current.		
When protected by a circuit breaker with a short-time trip response, the short-time response of the circuit breaker must be coordinated with the short-time rating of the transfer switch as marked below.		
SHORT CIRCUIT CURRENT	VOLTAGE	TIME DURATION
(RMS SYMMETRICAL AMPERES x 1000)	(VOLTS AC, MAXIMUM)	(SEC, MAXIMUM)
10	240	0.025
SHORT TIME CURRENT RATINGS		
THIS TRANSFER SWITCH DOES NOT INCLUDE SHORT-TIME CURRENT RATINGS		

SPECIFIC CIRCUIT BREAKER MANUFACTURER AND TYPE				
When protected by a circuit breaker of the specific manufacturer, type and ampere rating as marked below, this transfer switch is suitable for use in circuits capable of delivering the short-circuit current at the maximum voltage marked.				
SHORT CIRCUIT CURRENT	VOLTAGE	MANUFACTURER	TYPE	RATING
(RMS SYMMETRICAL AMPERES x 1000)	(VOLTS AC, MAXIMUM)			(AMPERES)
25	240	General Electric	SF	250A
SHORT TIME CURRENT RATINGS				
THIS TRANSFER SWITCH DOES NOT INCLUDE SHORT-TIME CURRENT RATINGS				

NOTE: 200A Service Entrance Rated TS 910/920 Transfer switches have an Interrupting Rating on the Utility supply of 10,000 Amps (RMS symmetrical).

18.4 200A, 3P NON-SERVICE ENTRANCE ATS UPSTREAM CIRCUIT PROTECTIVE DEVICES

SHORT-CIRCUIT WITHSTAND/CLOSING RATINGS		
When protected by a circuit breaker, this transfer switch is suitable for use in a circuit capable of delivering the short-circuit current for the maximum time duration and voltage marked below.		
The circuit breaker must include an instantaneous trip response unless the available short-circuit current is less than or equal to the short time rating of the transfer switch and the circuit breaker includes a short-time trip response.		
The maximum clearing time of the instantaneous trip response must be less than or equal to the time duration shown for the marked short-circuit current.		
When protected by a circuit breaker with a short-time trip response, the short-time response of the circuit breaker must be coordinated with the short-time rating of the transfer switch as marked below.		
SHORT CIRCUIT CURRENT	VOLTAGE	TIME DURATION
(RMS SYMMETRICAL AMPERES x 1000)	(VOLTS AC, MAXIMUM)	(SEC, MAXIMUM)
10	240	0.025
SHORT TIME CURRENT RATINGS		
THIS TRANSFER SWITCH DOES NOT INCLUDE SHORT-TIME CURRENT RATINGS		

SPECIFIC CIRCUIT BREAKER MANUFACTURER AND TYPE				
When protected by a circuit breaker of the specific manufacturer, type and ampere rating as marked below, this transfer switch is suitable for use in circuits capable of delivering the short-circuit current at the maximum voltage marked.				
SHORT CIRCUIT CURRENT	VOLTAGE	MANUFACTURER	TYPE	RATING
(RMS SYMMETRICAL AMPERES x 1000)	(VOLTS AC, MAXIMUM)			(AMPERES)
25	240	General Electric	SFH	250A
SHORT TIME CURRENT RATINGS				
THIS TRANSFER SWITCH DOES NOT INCLUDE SHORT-TIME CURRENT RATINGS				

NOTE: 200A Service Entrance Rated TS 910/920 Transfer switches have an Interrupting Rating on the Utility supply of 10,000 Amps (RMS symmetrical).

18.5 400A, 2P/3P NON-SERVICE ENTRANCE ATS UPSTREAM CIRCUIT PROTECTIVE DEVICES

SHORT-CIRCUIT WITHSTAND/CLOSING RATINGS		
When protected by a circuit breaker, this transfer switch is suitable for use in a circuit capable of delivering the short-circuit current for the maximum time duration and voltage marked below.		
The circuit breaker must include an instantaneous trip response unless the available short-circuit current is less than or equal to the short time rating of the transfer switch and the circuit breaker includes a short-time trip response.		
The maximum clearing time of the instantaneous trip response must be less than or equal to the time duration shown for the marked short-circuit current.		
When protected by a circuit breaker with a short-time trip response, the short-time response of the circuit breaker must be coordinated with the short-time rating of the transfer switch as marked below.		
SHORT CIRCUIT CURRENT	VOLTAGE	TIME DURATION
(RMS SYMMETRICAL AMPERES x 1000)	(VOLTS AC, MAXIMUM)	(SEC, MAXIMUM)
35	240	0.017
SHORT TIME CURRENT RATINGS		
THIS TRANSFER SWITCH DOES NOT INCLUDE SHORT-TIME CURRENT RATINGS		

SPECIFIC CIRCUIT BREAKER MANUFACTURER AND TYPE				
When protected by a circuit breaker of the specific manufacturer, type and ampere rating as marked below, this transfer switch is suitable for use in circuits capable of delivering the short-circuit current at the maximum voltage marked.				
SHORT CIRCUIT CURRENT	VOLTAGE	MANUFACTURER	TYPE	RATING
(RMS SYMMETRICAL AMPERES x 1000)	(VOLTS AC, MAXIMUM)			(AMPERES)
35	240	Eaton / Cutler Hammer	LD,LDB	600A
		Eaton / Cutler Hammer	HLD	600A
		Eaton / Cutler Hammer	LDC	600A
		Eaton / Cutler Hammer	CLD	600A
		Eaton / Cutler Hammer	CHLD	600A
		Eaton / Cutler Hammer	CLDC	600A
		Eaton / Cutler Hammer	MDL	800A
		Eaton / Cutler Hammer	HMDL	800A
		Eaton / Cutler Hammer	NB	800A
		Square D	LC	600A
		Square D	LI	600A
		Square D	LE, LX	600A
		Square D	LXI	600A
		Square D	DG	600A
		Square D	DJ	800A
		Square D	DL	800A
		Siemens	LD, LXD	600A
		Siemens	HLD,HLXD	600A
		Siemens	HHLD, HHLXD	600A
		Siemens	CLD	600A
Siemens	NLGA	600A		
Siemens	HLGA	600A		
Siemens	LLGA	600A		

SPECIFIC CIRCUIT BREAKER MANUFACTURER AND TYPE				
When protected by a circuit breaker of the specific manufacturer, type and ampere rating as marked below, this transfer switch is suitable for use in circuits capable of delivering the short-circuit current at the maximum voltage marked.				
SHORT CIRCUIT CURRENT	VOLTAGE	MANUFACTURER	TYPE	RATING
(RMS SYMMETRICAL AMPERES x 1000)	(VOLTS AC, MAXIMUM)			(AMPERES)
35	240	Siemens	LMD, LMXD	800A
		Siemens	HLMD, HLMXD	800A
		Siemens	MD, MXD	800A
		Siemens	HMD, HXMD	800A
		Siemens	CMD	800A
		Siemens	NMG	800A
		Siemens	HMG	800A
		Siemens	LMG	800A
		Siemens	SLD	600A
		Siemens	SHLD	600A
		Siemens	SCLD	600A
		Siemens	SMD	800A
		Siemens	SHMD	800A
		Siemens	SCMD	800A
		Siemens	LMD, LMXD	800A
		Siemens	HLMD, HLMXD	800A
		Siemens	MD, MXD	800A
		Siemens	HMD, HXMD	800A
		Siemens	CMD	800A
		Siemens	NMG	800A
		Siemens	HMG	800A
		General Electric	SGHA	600A
		General Electric	FGN	600A
		General Electric	FGH, FGL, FGP	600A
		Merlin Gerin	CJ600N	600A
		Merlin Gerin	CJ600H	600A
		ABB	T5	600A
		ABB	T6	600A
50	240	Eaton/Cutler Hammer	LD	600A
SHORT TIME CURRENT RATINGS				
THIS TRANSFER SWITCH DOES NOT INCLUDE SHORT-TIME CURRENT RATINGS				

NOTE: 400A Service Entrance Rated TS 910/920 Transfer switches have an Interrupting Rating on the Utility supply of 25,000 Amps (RMS symmetrical).

For other circuit breaker types and sizes not listed, contact Thomson Power Systems.

TSC 9 Transfer Switch Controller

18.6 DESCRIPTION

The TSC 9 controller utilizes microprocessor-based design technology, which provides high accuracy for all voltage sensing and timing functions. The TSC 9 is factory configured to control all the operational functions and operating status of the automatic transfer switch. The TSC 9 controller consists of a printed circuit board (PCB), which is mounted inside the transfer switch on the left-hand side wall of the enclosure. A faceplate is provided with graphic label showing status lights and operation pushbuttons which are visible through the front cover of the transfer switch.



18.7 ELECTROSTATIC DISCHARGE PRECAUTIONS



CAUTION

contents subject to damage by
STATIC ELECTRICITY

The TSC 9 controller contains static-sensitive parts. Please observe the following anti-static precautions at all times when handling this equipment. Failure to observe these precautions may cause equipment failure and/or damage.

- Discharge body static charge before handling the equipment (contact a grounded surface and maintain contact while handling the equipment, a grounded wrist strap can/should also be utilized).
- Do not touch any components on the printed circuit board with your hands or any other conductive equipment.
- Do not place the equipment on or near materials such as Styrofoam, plastic and vinyl. Place the equipment on grounded surfaces and only use an anti-static bag for transporting the equipment.

18.8 DIELECTRIC TESTING

Do not perform any high voltage dielectric testing on the TSC 9 controller. The control circuit isolation plug connected to the TSC 9 must be removed if high voltage dielectric testing is performed on the transfer switch.

18.9 TSC 9 FACEPLATE

The TSC 9 Controller faceplate is shown as in FIGURE 1

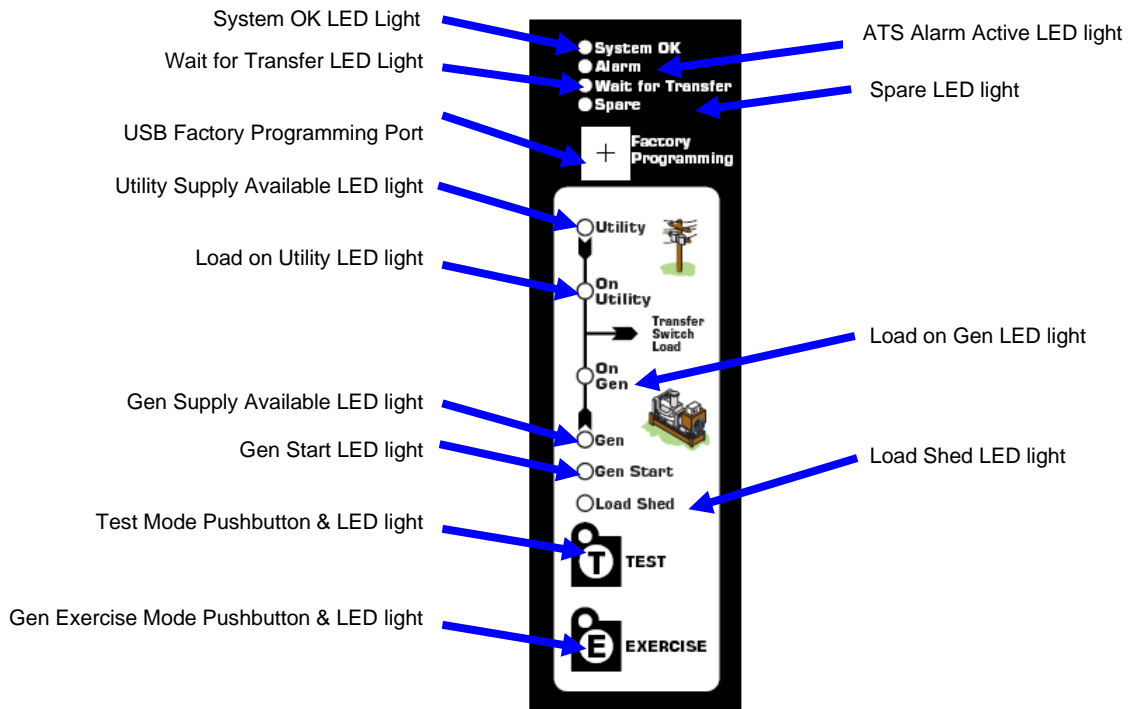

18.10 TSC 9 FACEPLATE LIGHTS AND PUSHBUTTON OPERATION

Operation of the TSC 9 controller lights and pushbuttons are described in the following table:

	Light Color	Label	Light Off	Light On	Light Slow Flash	Light Fast Flash
●	Green	System OK			System is functioning normally.	System is running production or burn-in tests
●	Yellow	Alarm	No fault condition has occurred since last system reset.	A fault condition has occurred since last system reset.		
●	Yellow	Wait For Transfer	Not currently waiting for in-phase transfer.	Currently waiting for in-phase transfer.		A in-phase transfer related fault has occurred.
●	Green	Diagnostic	Unused. Always off.			
●	Green	Utility	Utility voltage/freq not good.	Utility voltage/freq good.		Utility unexpected phase rotation
●	Green	On Utility	Load is not on utility.	Load is on utility.		A utility-related transfer fault has occurred.
●	Red	On Generator	Load is not on generator.	Load is on generator.		A gen-related transfer fault has occurred.
●	Red	Generator	Gen voltage/freq not good.	Gen voltage/freq good.		Gen unexpected phase rotation
●	Red	Generator Start	Generator is not commanded to start/run.	Generator is commanded to start/run.		
●	Yellow	Load Shed	Load is not being shed.	Load is being shed.		
●	Yellow	TEST	Manual test is not active.	Manual test is currently active.	Manual test is active, initiated remotely.	
●	Yellow	EXERCISE	Exercise is not active or enabled	Exercise is enabled but not currently active.	Exercise is currently active.	An exercise related fault has occurred.
Special Conditions						
		Lamp Test	All indicators flash fast together.			
		System Reset	Test and Exercise lights flash fast alternatively. All other indicators are off.			

18.11 TSC 9 PRINTED CIRCUIT BOARD

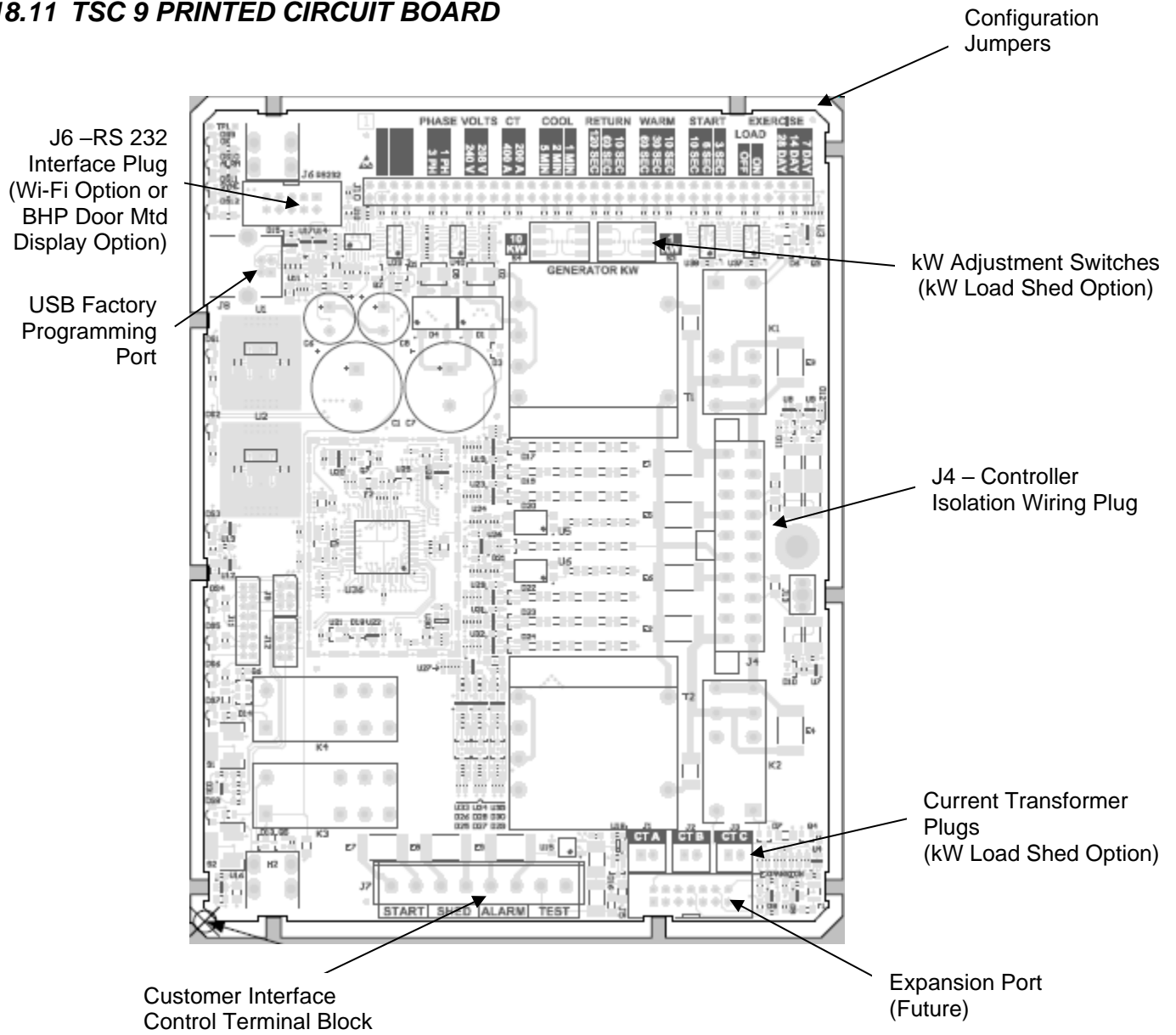

FIGURE 2

18.11.1 PRINTED CIRCUIT BOARD USER INTERFACES

The TSC 9 has the following user interface items located on the printed circuit board.

18.11.1.1 *Customer Interface Control Terminal Block*

All control wiring connections are made directly on the TSC 9 Transfer controller. A removable plug-in clamp screw terminal block is provided at the bottom end of the controller (see photo below).

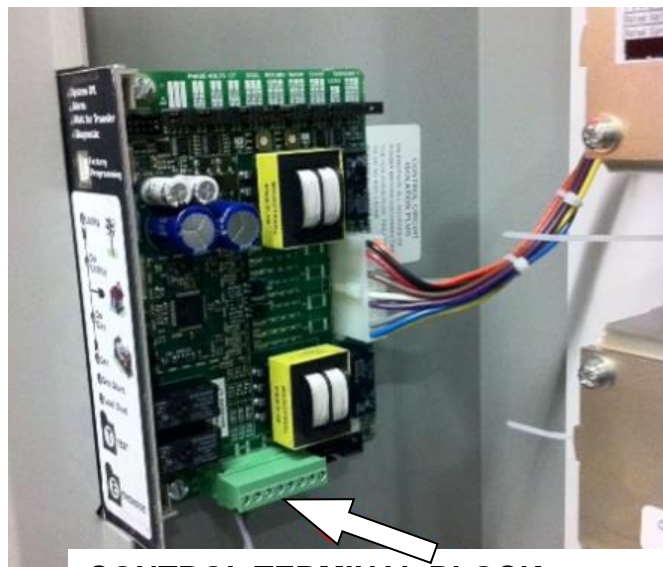

CONTROL TERMINAL BLOCK

Terminals are provided for the following control features: Refer to wiring diagram shown below for connection numbers.

- Engine Start Stop (dry contact output)
- Load Shed (dry contact output)
- Alarm Output (solid state output)
- Remote Test Input (dry contact input)

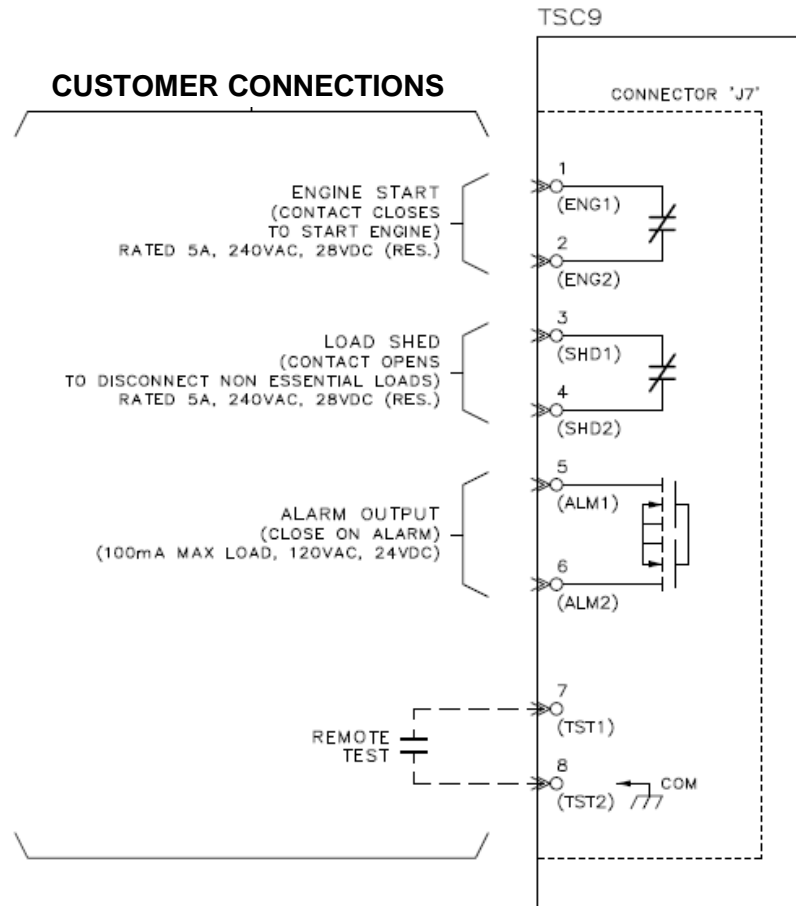

18.11.1.2 Configuration Jumpers

The TSC 9 controller provides 10 user-configurable functions which utilize jumpers located directly on the printed circuit board as per FIGURE 2. They are used for configuration of main system operating parameters such as voltage, phases and timers. Refer to SECTION 19.15 (CONFIGURATION INSTRUCTIONS) for further information.

18.11.1.3 kW Adjustment Switches

The TSC 9 controller provides 2 kW load adjustment switches which are utilized when the kW Load Shed optional accessory is provided with the transfer Switch. Additional information on TS 910/920 kW Load shed optional accessory can be obtained from our Website (www.thomsonps.com).

18.11.1.4 Controller Isolation wiring Plug (J4)

A 20 pin wiring plug is utilized on the TSC 9 controller for connecting all interconnecting wiring to the transfer switch mechanism. This plug can be used

for disconnecting all control power to the TSC 9 controller for servicing or manual ATS operating procedure.

18.11.1.5 *Current Transformer Plugs*

The TSC 9 controller provides three plugs to interconnect external Current Transformers when the transfer switch is supplied with the kW Load Shed optional accessory. Current transformers with specific two pin plug connectors and 0-0.3VAC output can only be used. Additional information on TS 910/920 kW Load shed optional accessory can be obtained from our Website (www.thomsonps.com).

18.11.1.6 *Expansion Port*

The TSC 9 controller provides an expansion port for future use only.

18.11.1.7 *USB Factory Programming Port*

A USB port is provided on the front faceplate of the TSC 9 controller. It is utilized for factory programming and/or service diagnostic use only.

18.11.1.8 *RS 232 Interface Plug (Wi-Fi Option or BHP Operator Interface Panel)*

A RS 232 port is provided on the printed circuit board of the TSC 9 controller. It is utilized for interconnection to a Wi-Fi remote messaging module when this optional accessory is added to the transfer Switch or with the BHP Operator Interface Panel (TS 920 series only). Additional information on TS 910 Wi-Fi Remote Messaging optional accessory can be obtained from our Website: (www.thomsonps.com).





18.12 TSC 9 OPERATING INSTRUCTIONS

To operate the TSC 9 controller and associated transfer switch using the front faceplate pushbuttons, refer to the following table:

18.12.1 AUTOMATIC SEQUENCE OF OPERATION

Refer to [SECTION 5](#) General Theory Of Operation of this manual for information on automatic operation.

18.12.2 TSC 9 Controller Operation Pushbuttons

<p>TEST</p>  <p>TEST</p>	<p>To Load Test, press and hold the “T” pushbutton for 2 seconds until LED light above pushbutton comes ON. The generator will start and transfer on load per Automatic Sequence.</p> <p>To cancel Load Test, press and hold the “T” pushbutton for 2 seconds until LED light above pushbutton goes OFF. The load will re-transfer back to the utility power per Automatic Sequence.</p>
<p>EXERCISE</p>  <p>EXERCISE</p>	<p>To set Exercise mode and schedule, press and hold the “E” pushbutton for 2 seconds until LED light above pushbutton starts flashing. The generator will start and operate off load (or ON Load if selected). The generator will operate for 30 minutes then will automatically stop. Exercise LED will change from flashing to continuously ON, indicating exercise clock schedule is enabled. The generator will automatically start and exercise in 7, 14 or 28 day cycles as selected.</p> <p>To cancel Exercise, press and hold the “E” pushbutton for 2 seconds until LED light above pushbutton goes OFF.</p> <p>NOTE: When the Exercise Test is first enabled, <u>do not cancel the test until the generator set has started and has transferred on load for at least 60 seconds</u>. If the Test is cancelled before 60 seconds has expired, the fail to exerciser alarm will be triggered and the generator set will <u>not</u> correctly exercise automatically in the future until the alarm is reset.</p>
<p>TIMER BYPASS LAMP TEST ALARM RESET</p>  <p>TEST</p>  <p>EXERCISE</p>	<p>TIMER BYPASS: Press and hold the “E” and “T” pushbutton together for 2 seconds to bypass any active time delay.</p> <p>LAMP TEST: Press and hold the “E” and “T” pushbutton together for 5 seconds to activate lamp test function.</p> <p>ALARM RESET: Press and hold the “E” and “T” pushbutton together for 10 seconds until alarm LED goes out.</p>

NOTE

Should the generator set fail while on load when in the Test or Exercise modes, the transfer switch will automatically retransfer the load back to the utility supply if within nominal limits. The utility return timer will be bypassed in this condition.

18.13 TSC 9 OPERATING MODE DESCRIPTIONS

18.13.1 TRANSFER SWITCH FAIL ALARM LOGIC

The TSC 9 controller contains logic to detect abnormal operation during various failure modes. Detailed operating logic is as follows:

18.13.1.1 **Fail to Transfer (Phase Rotation Miss-match):**

On 3-Phase systems, the TSC 9 controller monitors the phase rotation of the system and will prevent a transfer to either source if it is unexpectedly not matching with the other source. The ATS will operate correctly with either a positive (A-B-C) phase rotation system or a negative (C-B-A) rotation system provided both sources have the same rotation.

Should the generator fail to transfer on load when signaled to do so due to a miss-match phase rotation with the utility supply, the following sequence of events will occur:

- **Generator Source Available LED (red) Flashes** and the transfer to gen will be inhibited.
- **Alarm LED Activated:** the alarm LED will be activated. The LED will not go out until the alarm condition is reset.
- **Alarm Output Signal Activated:** the output signal on customer terminals #5 & #6 will be activated. The alarm output signal will be terminated once the alarm condition is reset.

Should the Utility fail to transfer on load when signaled to do so due to a miss-match phase rotation with the utility supply, the following sequence of events will occur:

- **Utility Source Available LED (green) Flashes** and the transfer to utility will be inhibited.
- **Alarm LED Activated:** the alarm LED will be activated. The LED will not go out until the alarm condition is reset.
- **Alarm Output Signal Activated:** the output signal on customer terminals #5 & #6 will be activated. The alarm output signal will be terminated once the alarm condition is reset.

18.13.1.2 **Utility Limit Switch Failure:**

Should the utility power contactor limit switch fail to close when the contactor is in the utility position, an alarm condition will be activated after a 10 second delay. This alarm condition will cause the following events to occur:

- **Force Transfer:** a forced transfer to the generator supply will be activated. A generator start signal will be initiated to start the generator and load will transfer to the generator supply if within normal limits. Re-transfer back to the utility supply will not occur until the Transfer Fail alarm condition is reset.
- **On Utility LED Flashes:** the On Utility LED will begin flashing to indicate that the utility limit switch is not operating correctly. The LED will flash until the alarm condition is reset.
- **Alarm LED Activated:** the Alarm LED' will be activated. The LED will not go out until the alarm condition is reset.
- **Alarm Output Signal Activated:** the output signal on customer terminals #5 & #6 will be activated. The alarm output signal will be terminated once the alarm condition is reset.

18.13.1.3 **Generator Limit Switch Failure:**

Should the generator power contactor limit switch fail to close when the contactor is in the generator position, an alarm condition will be activated after a 10 second delay.

This alarm condition will cause the following events to occur:

- **Force Transfer:** a forced transfer to the utility supply will be activated. The load will automatically be transferred to the utility supply if within normal limits. Re-transfer back to the generator supply will not occur until the Transfer Fail alarm condition is reset and the generator is still called to start for Test or Exercise operating modes.
- **On Generator LED Flashes:** the On Generator LED will begin flashing to indicate that the generator limit switch is not operating correctly. The LED will flash until the alarm condition is reset.
- **Alarm LED Activated:** the alarm LED' will be activated. The LED will not go out until the alarm condition is reset.
- **Alarm Output Signal Activated:** the output signal on customer terminals #5 & #6 will be activated. The alarm output signal will be terminated once the alarm condition is reset.



18.13.1.4 **Generator Fail to Perform an Exercise Operation:**

Should the generator fail to perform an automatic exercise mode (i.e. fail to start or fail on load), an alarm condition will be activated after a 60 second delay. This alarm condition will cause the following events to occur:

- **Exercise LED Flashes:** the Exercise LED will begin flashing to indicate that the generator has not performed an 'Exercise mode correctly. The LED will flash until the alarm condition is reset.
- **Alarm LED Activated:** the Alarm LED will be activated. The LED will not go out until the alarm condition is reset.
- **Alarm Output Signal Activated:** the output signal on customer terminals #5 & #6 will be activated. The alarm output signal will be terminated once the alarm condition is reset.



18.13.1.5 **Fail to Transfer (In-Phase Detection)**

Should the transfer switch not immediately transfer following expiry of a normal automatic mode sequence timer (e.g. Gen Warmup Timer, Utility Return Timer) and both generator and utility supplies are available, the generator and utility supplies may not be in phase as required by the in-phase transfer detection sensor. Should the generator and utility supplies fail to reach an in-phase condition for a time period of 5 minutes, an alarm condition will be activated. This alarm condition will cause the following events to occur:

- **In-Phase Bypass Transfer:** The transfer switch will bypass the in-phase detection circuitry and force a transfer to the intended source. Re-transfer back to the original source will be permitted with the Wait to Transfer alarm still present.
- **Wait to Transfer LED Flashes:** the Wait to Transfer LED will begin flashing to indicate that the transfer switch did not detect an in-phase condition for a 5 minute period. The LED will flash until the alarm condition is reset.
- **Alarm LED Activated:** the Alarm LED will be activated. The LED will not go out until the alarm condition is reset.
- **Alarm Output Signal Activated:** the output signal on customer terminals #5 & #6 will be activated. The alarm output signal will be terminated once the alarm condition is reset.

18.14 TEST MODES

18.14.1 UTILITY POWER FAIL SIMULATION (LOAD TEST)

To simulate a utility power failure condition, a Test pushbutton is provided on the front faceplate. Once the mode is initiated, the gen start will be activated. Once the generator accelerates to nominal voltage and frequency levels, the load will automatically transfer to the generator supply. To terminate the Test Mode, the TEST pushbutton must be used. When the pushbutton is released the LED light will go out and, the load will re-transfer back to the utility supply following expiry of the Utility Return delay timer.

NOTE

The load will automatically re-transfer to the utility supply should the generator fail while on load.

18.14.2 GENERATOR EXERCISE TEST

The TSC 9 controller contains an automatic generator exercise mode operating feature. The exercise feature can be user configured to automatically start the generator every 7, 14, or 28 days and operate it for 30 minutes (fixed) either 'ON' or 'OFF' load (user configurable). Configuration settings are done using PCB mounted jumpers. Generator starting times & days are automatically set when the exercise mode is initiated via faceplate pushbutton.

Example: If the generator exercise mode is activated via the controller pushbutton at 8:00am on Monday morning, the generator will automatically start and operate for 30 minutes then will automatically stop. If the TSC 9 controller is programmed for a 7 day schedule, the generator will automatically start at 8:00am Monday morning the following week (i.e. 7 days later) and run for 30 minutes then stop.

To change generator start time and day of exercising, the Exercise mode must be canceled, and then reactivated at the desired start time and day.

NOTE

- 1. The TSC 9 contains a 24-hour power reserve feature to maintain exercise timer settings in the event of power outages.**
- 2. The load will automatically re-transfer to the utility supply should the generator fail while in the test mode.**
- 3. To bypass a 30-minute exercise run period, press and hold the Exercise pushbutton on for 2 seconds until the LED remains on.**

The Generator Exercise LED light will operate as follows:

- LED ON - Exercise Timer is initiated, the 7, 14 or 28 day cycle timer is active and the generator is in the off state.
- LED FLASHING - Exercise Timer is initiated, the 30 minute run timer is active and the generator is running on load.
- LED OFF - Exercise Timer is not initiated and the 7, 14 or 28 day cycle timer is not active.

To terminate the Generator Exercise Mode, the Exercise pushbutton must be held on for 2 seconds until the LED light above the pushbutton starts flashing. When the pushbutton is released, the LED light will go out and the system will return to normal operation.

NOTE

When the Exercise Test is first enabled, do not cancel the test until the generator set has started and has transferred on load for at least 60 seconds. If the Test is cancelled before 60 seconds has expired, the fail to exerciser alarm will be triggered and the generator set will not correctly exercise automatically in the future until the alarm is reset.

18.14.3 REMOTE TEST

To activate a remote load test, a contact is to be remotely closed between terminal #7 and terminal #8 on the Customer Interface Terminal Block. When the contact closes, and generator start will be activated and once the generator accelerates to nominal voltage and frequency levels, the load will automatically transfer to the generator supply. When the remote contact is opened, the load will re-transfer back to the utility supply following expiry of the Utility Return delay timer. The Engine cooldown time sequence will be initiated when the test mode is terminated.

NOTE:

The load will automatically re-transfer to the utility supply should the generator fail while on load.

18.15 TRANSFER FAIL FAULT RESET

To reset a Transfer Fail condition (i.e. When either the Load on Gen or Load on Utility Lights are flashing and the ATS load is transferred to the alternate source), both faceplate pushbuttons (i.e. Test & Exercise) must be held on for 10 seconds until all Lights on the faceplate start flashing. Once the alarm condition is reset, the load will automatically retransfer back to the original source if within normal limits.

18.16 LAMP TEST

To initiate a Lamp Test, both faceplate pushbuttons (i.e. Test & Exercise) must be held on longer than 5 seconds until all Lights on the faceplate illuminate in a flashing mode.

18.17 TIMER BYPASS

To bypass an active timing sequence (e.g. utility return timer, cooldown timer, warmup timer) during operation, both faceplate pushbuttons (i.e. Test & Exercise) must be held on for 2 seconds until all Lights on the faceplate start flashing.

18.18 TSC 9 VOLTAGE SENSING

The TSC 9 controller contains voltage sensing for each phase voltage of the utility and generator supplies. The under voltage setting is for a falling utility voltage (i.e. drop-out setting) on any one phase. The under voltage sensor will reset to normal when the system voltage rises 10% above the drop-out setting (i.e. differential value).

The under voltage drop-out setpoint for both utility and generator supplies is fixed at 70% of system voltage. The under voltage pick-up setpoint for both utility and generator supplies is fixed at 80% of system voltage.

NOTE

To override momentary utility under voltage fluctuations, the TSC 9's Engine Start Delay Timer feature is utilized.

18.19 TSC 9 SYSTEM FREQUENCY DETECTION

The TSC 9 controller can be utilized on either 50Hz or 60Hz nominal systems. The TSC 9 controller Auto-Detects what the system frequency is within 2-3 seconds of utility supply energization. No programming or jumper setting confirmation is required for system frequency.

NOTE

For the System Frequency Auto-Detection feature to work correctly, the utility supply must be connected and energized before the generator source is energized. The TSC 9 Controller is factory tested with a 60Hz system and the controller will not change its system frequency unless a new Utility source with different frequency is energized.

18.20 TSC 9 GENERATOR FREQUENCY SENSING

The TSC 9 controller contains frequency sensing for the generator supply. The under frequency setting is for a falling generator frequency (i.e. drop-out setting). The under frequency sensor will reset to normal when the system frequency rises 20% above the drop-out setting (i.e. differential value).

The under frequency drop-out setpoint for the generator supply is fixed at 85% of system frequency. The under frequency pick-up setpoint for the generator supply is fixed at 90% of system frequency.

NOTE

To override momentary under frequency fluctuations, the under frequency sensor is provided with a transient time delay period of 5 seconds which is non-adjustable.

18.21 TSC 9 CONFIGURATION INSTRUCTIONS

All user configuration of the TSC 9 controller is accomplished using hardware jumpers located on top of the printed circuit board as per the following picture. No software programming is required. The hardware jumpers are used for configuration of main operating parameters such as system voltage, phases, and adjustable time delays.

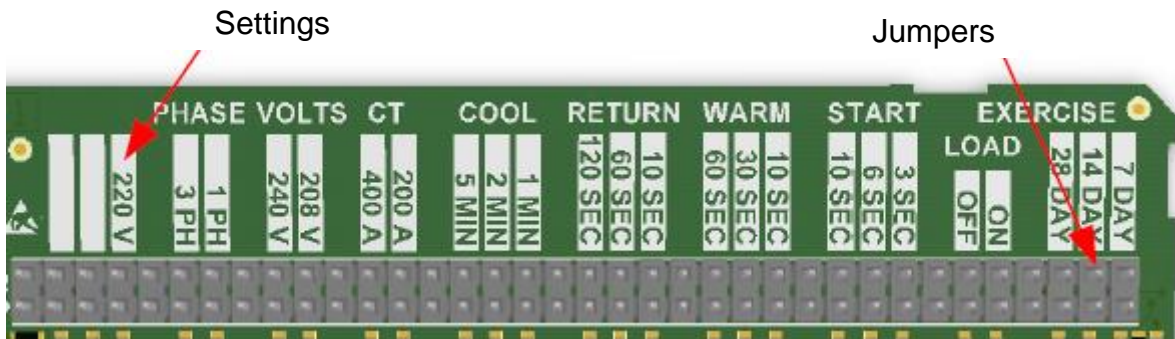

18.21.1 FACTORY DEFAULT JUMPER SETTINGS

All TSC 9 configuration jumpers are set to default settings at the factory as per the following table and should not require further setting.

TSC 9 CONTROLLER CONFIGURATION JUMPERS		
FUNCTION	SETTING	FACTORY DEFAULT
EXERCISE TEST CYCLE	7 DAY	X
EXERCISE TEST CYCLE	14 DAY	
EXERCISE TEST CYCLE	28 DAY	
EXERCISE LOAD TRANSFER	ON LOAD	
EXERCISE LOAD TRANSFER	OFF LOAD	X
ENGINE START DELAY	0 sec (no jumper)	
ENGINE START DELAY	3 SEC	X
ENGINE START DELAY	6 SEC	
ENGINE START DELAY	10 SEC	
ENGINE WARMUP TIME	3 sec (no jumper)	
ENGINE WARMUP TIME	10 SEC	X
ENGINE WARMUP TIME	30 SEC	
ENGINE WARMUP TIME	60 SEC	
UTILTY RETURN DELAY	3 sec (no jumper)	
UTILTY RETURN DELAY	10 SEC	
UTILTY RETURN DELAY	60 SEC	
UTILTY RETURN DELAY	120 SEC	X
ENGINE COOLDOWN TIME	3 sec (no jumper)	
ENGINE COOLDOWN TIME	1 MIN	
ENGINE COOLDOWN TIME	2 MIN	X
ENGINE COOLDOWN TIME	5 MIN	
CURRENT TRANSFORMER SIZE	200A	
CURRENT TRANSFORMER SIZE	400A	
SYSTEM VOLTAGE	208V	X (TS 910 3PH only)
SYSTEM VOLTAGE	240V	X (1PH only)
SYSTEM VOLTAGE	220V	X (TS 923 only)
SYSTEM PHASE	1 Ph	X (1PH only)
SYSTEM PHASE	3 Ph	X (3PH only)
VOLTAGE/FREQUENCY SENSOR SETTINGS		
UTILTY UNDER VOLTAGE PICKUP	FIXED	80%
UTILTY UNDER VOLTAGE DROPOUT	FIXED	70%
GEN UNDER VOLTAGE PICKUP	FIXED	80%
GEN UNDER VOLTAGE DROPOUT	FIXED	70%
GEN UNDER FREQUENCY PICKUP	FIXED	90%
GEN UNDER FREQUENCY DROPOUT	FIXED	85%

The following configuration jumpers are provided on the printed circuit board to program the TSC 9 controller:

WARNING

The configuration jumper settings must not be changed while the Transfer Switch and TSC 9 controller are energized. All sources of power to the transfer switch must be de-energized prior to changing any configuration jumper settings. Failure to do so may cause personnel injury and/or death.

18.21.2 SYSTEM VOLTAGE JUMPERS

Three jumpers are provided to set the required system operating voltage (i.e. Phase-to-Phase Voltage) of the TSC 9 controller and transfer switch as follows;

- **208V:** For 208V nominal applications, a jumper must be placed across the 2 pins, adjacent to the text on the PCB '208V'.
- **220V:** For 220V nominal applications, a jumper must be placed across the 2 pins, adjacent to the text on the PCB '220V'.
- **240V:** For 240V nominal applications, a jumper must be placed across the 2 pins, adjacent to the text on the PCB '240V'.

Only one jumper must be placed on the voltage selection jumpers. Failure to do so will cause improper operation. When a system voltage is selected, the TSC 9's utility and generator under voltage setpoint percentage setting will be automatically programmed to correspond to the sensing input voltage (e.g. with a 240V system voltage selected, and a 70% under voltage setting, the under voltage sensor will be activated below 168VAC).

18.21.3 SYSTEM PHASE JUMPERS

Two jumpers are provided to set the required number of system phases for the TSC 9 controller as follows;

- **1 PH:** For single-phase applications, a jumper must be placed across the 2 pins, adjacent to the text on the PCB '1 PH'. Phase C voltage sensing input is ignored in the single-phase mode.
- **3 PH:** For 3-phase applications, a jumper must be placed across the 2 pins, adjacent to the text on the PCB '3 PH'.

Only one jumper must be placed on the selection jumpers. Failure to do so will cause improper operation.



18.21.4 GEN EXERCISE LOAD TEST MODE (LOAD) JUMPERS

Two jumpers are provided to set the required exercise testing mode for the TSC 9 controller as follows;

- **On:** for applications where the generator is to be exercised with load, a jumper must be placed across the 2 pins, adjacent to the text on the PCB On:
- **Off:** for applications where the generator is to be exercised without load (i.e. Off load), a jumper must be placed across the 2 pins, adjacent to the text on the PCB Off:

Only one jumper must be placed on the selection jumpers. Failure to do so will cause improper operation.

NOTE

The Off load Test mode is the factory default setting.

NOTE

Should utility power fail during a no-load test operation, the load will automatically transfer to the generator and will re-transfer back when utility power is restored to within normal conditions. The engine will continue to run until the 30 minute exercise time delay period expires.

18.21.5 ENGINE START DELAY JUMPERS

A TSC 9 PCB mounted jumper is provided to configure the desired Engine Start Delay timer settings. Three time settings are provided - 3 seconds, 6 seconds or 10 seconds. A jumper must be placed across the 2 pins, adjacent to the desired time as shown on the PCB.

NOTE: If no intentional time delay is required, the jumper maybe left off for Zero Seconds.

Refer to **SECTION 19.15.1** for the factory default settings of the Engine Start Delay timer.

18.21.6 ENGINE WARMUP DELAY JUMPERS

A TSC 9 PCB mounted jumper is provided to configure the desired Engine Warmup Delay timer settings. Four time settings are provided – 3 seconds (no



jumpers), 10 seconds, 30 seconds or 60 seconds. A jumper must be placed across the 2 pins, adjacent to the desired time as shown on the PCB.

Refer to **SECTION 19.15.1** for the factory default settings of the Engine Warmup Delay timer

18.21.7 ENGINE COOLDOWN DELAY JUMPERS

A TSC 9 PCB mounted jumper is provided to configure the desired Engine Cooldown Delay timer settings. Four time settings are provided – 3 seconds (no jumpers), 1 minute, 2 minutes or 5 minutes. A jumper must be placed across the 2 pins, adjacent to the desired time as shown on the PCB.

Refer to **SECTION 19.15.1** for the factory default settings of the Engine Cooldown Delay timer

18.21.8 UTILITY RETURN DELAY JUMPERS

A TSC 9 PCB mounted jumper is provided to configure the desired Utility Return Delay timer settings. Four time settings are provided – 3 seconds (no jumpers), 10 seconds, 60 seconds or 120 seconds. A jumper must be placed across the 2 pins, adjacent to the desired time as shown on the PCB.

Refer to **SECTION 19.15.1** for the factory default settings of the Utility Return Delay timer

18.21.9 CURRENT TRANSFORMER SIZE JUMPERS

A TSC 9 PCB mounted jumper is provided to configure the size of current transformers which are utilized when the kW Load shed option is used with the transfer switch. When the kW Load shed option is not used, no jumper setting is required. Additional information on TS 910/920 kW Load shed optional accessory can be obtained from our Website (www.thomsonps.com).

18.22 LOAD SHED

Load Shed operation can be configured to three different settings as follows:

1. Disabled (Factory Default)
2. Basic
3. kW Load Management

The transfer switch is supplied from the factory with the Load shed disabled. Refer to the following table for detailed description of load shed operating modes, their application and settings required on the TSC 9.

Load Shed Feature	Application	Feature Description	TSC 9 CT Jumper Position	TSC 9 kW Settings
Disabled (factory default)	Load Shed feature not used for applications using generator set & ATS which are sized for whole house load	Load Shed Relay & Status LED Indicator are disabled	None	00
Basic	Basic load shed feature used when generator set is sized for only partial home load and requires automatic control to shed selected non-essential load.	<ul style="list-style-type: none"> - Load Shed Relay & Status LED Indicator are enabled on TSC 9 controller - Load Shed Relay & LED are activated whenever Generator is On Load and resets when load returns to utility power - Normally Closed contact opens during Load shed condition to open control circuit of connected non-essential load 	None	>00 Setting
kW Load Management (feature sold separately- refer to associated instructions for further details)	kW Load Management Load shed used when generator set is sized for only partial home load and requires automatic control to shed selected non-essential load. Feature provides added benefit of maximizing available generator capacity where home loads vary over time. Requires additional Current Transformers	<ul style="list-style-type: none"> - Load Shed Relay & Status LED Indicator are enabled on TSC 9 Controller - Load Shed Relay & LED are controlled via CT input signal (refer to kW load Management sequence of operation) - Normally Closed contact opens during Load shed condition to open control circuit of connected non-essential load 	200A or 400A CT Position (100A Model uses 200A CT)	>00 Setting to be 95% of Gen kW rating

When Load shed operation is required, the load shed output relay contact must be connected to control an external non-essential load. The output contact is normally closed and opens when a load shed condition is activated. The output contact is rated for 5A, 240VAC (resistive) maximum. The output contact can be directly connected to control devices such as air conditioners with thermostat control input.

For controlling loads that do not have integral control inputs, suitably rated AC power contactor panels must be used for interconnection with the Load Shed contact. Refer to following typical connection example:

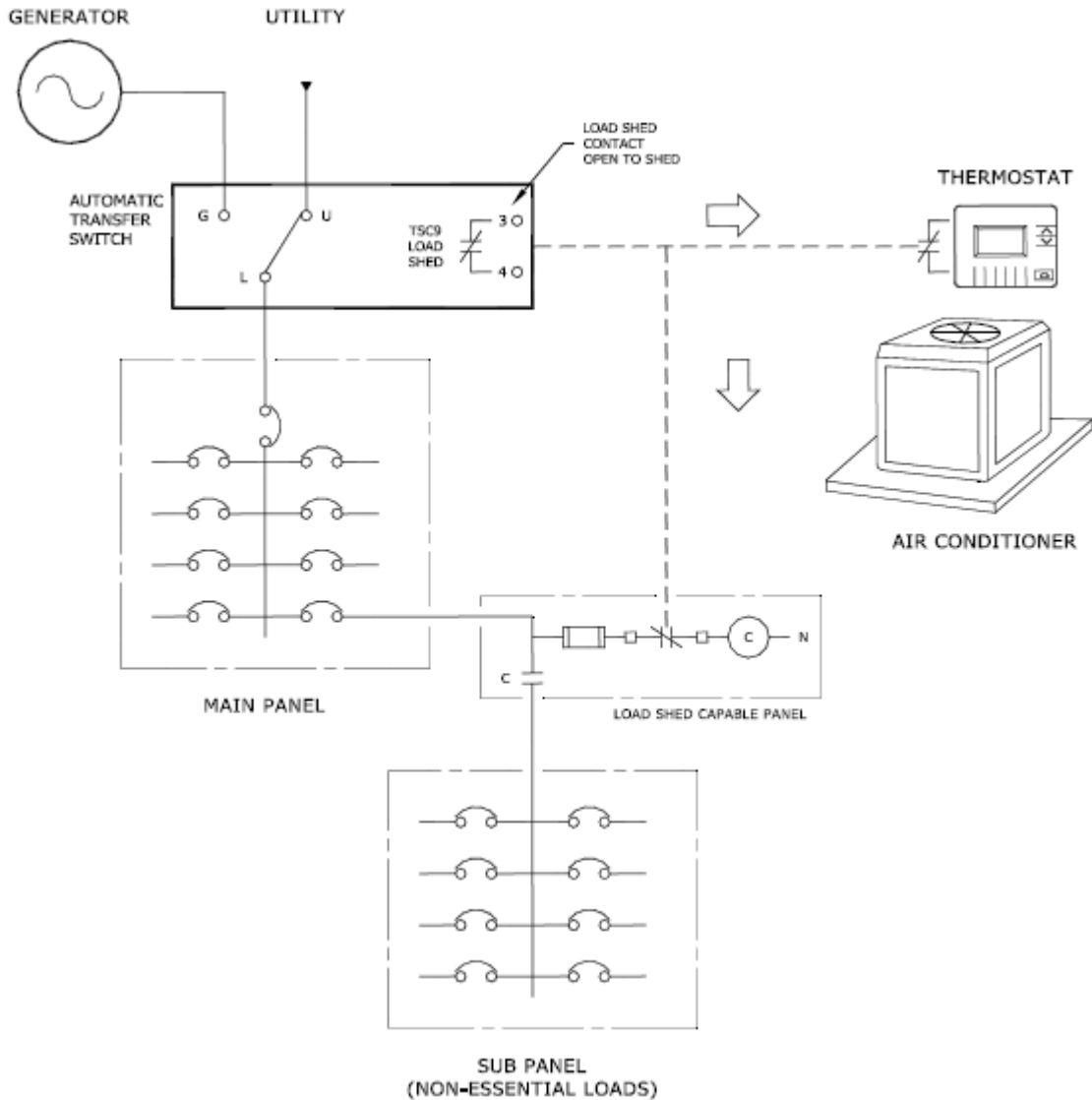

Additional information on TS 910/920 kW Load shed optional accessory can be obtained from our Website (www.thomsonps.com).

19 BHP Operator Interface Panel (TS 920 Series Only)

19.1 DESCRIPTION

A door mounted operator interface panel, Model BHP, is provided standard on all TS 920 Series Transfer Switches. It provides the same operator interface indicator lights and control pushbuttons as are provided on the TSC 9 Controller front panel. The BHP is interconnected to the TSC 9 Controller via single RS232 communication cable.

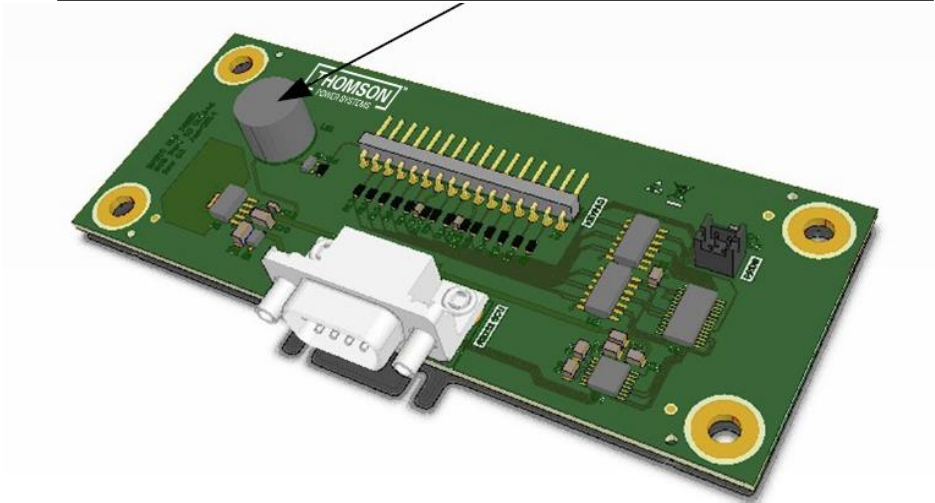
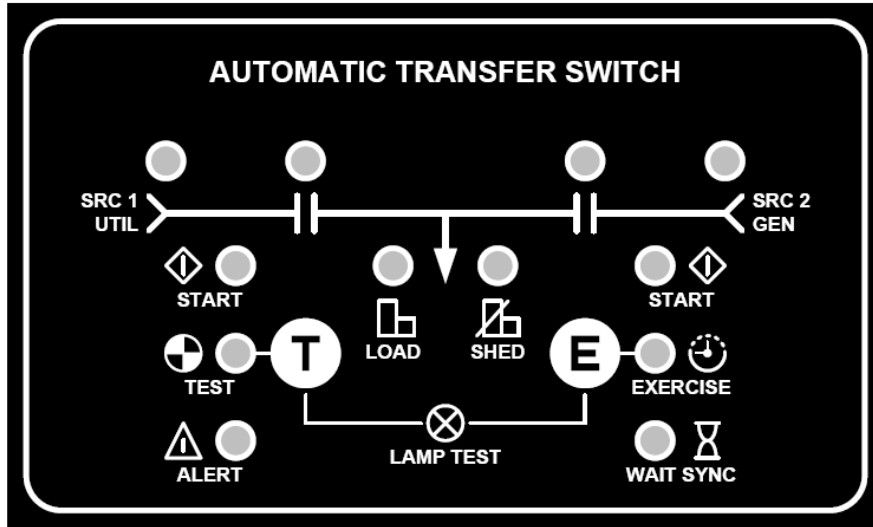

20 TS 910/TS 920 SCHEMATIC DIAGRAM

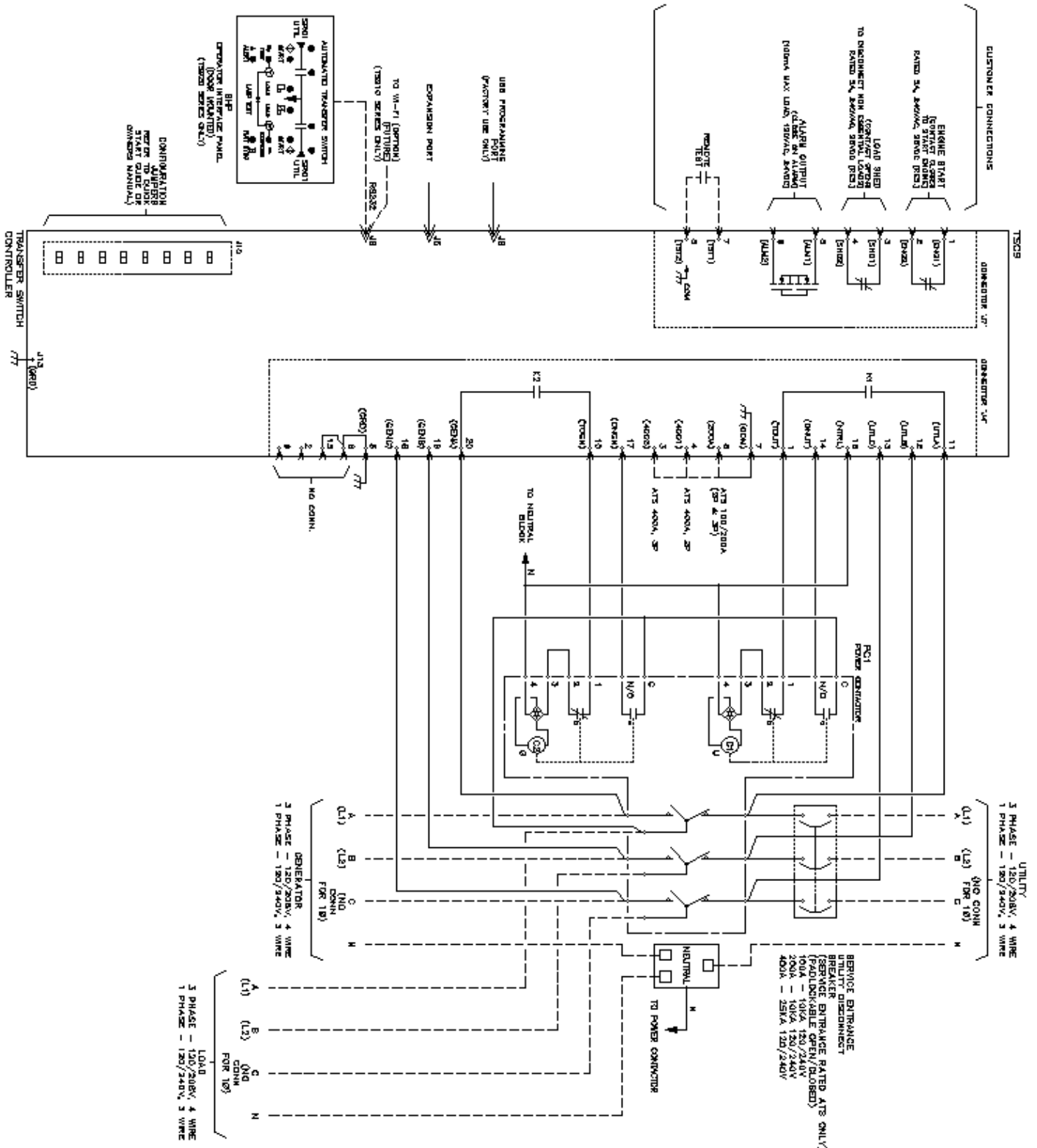

21 TROUBLESHOOTING

Symptom	Possible Causes
<p>Will not re-transfer to utility source upon restoration</p>	<ul style="list-style-type: none"> • TSC 9 Isolation plug is disconnected • A test mode has been activated (check TSC 9 status LED) • Utility voltage is below 80% rated voltage (check utility source for adequate voltage) • A loose control connection • Defective utility solenoid coil • TSC 9 has incorrect voltage configuration jumper setting for correct system voltage • Defective TSC 9 controller (verify output signals) • TSC 9 has “Transfer Fail” alarm activated as indicated by flashing Load on Utility LED. Determine cause of alarm and rectify before TSC 9 is reset • In-phase transfer control has not detected an ‘in-phase condition to permit transfer. Transfer switch will automatically bypass an in-phase transfer after 5 minutes • There is a phase rotation difference between the Utility and Generator source. Change Power cabling to match both sources phase rotation
<p>Will not transfer to generator source upon failure of utility source</p>	<ul style="list-style-type: none"> • TSC 9 Isolation plug is disconnected • Generator set not producing enough voltage/frequency or output circuit breaker open • TSC 9 has incorrect voltage configuration jumper setting for correct system voltage • Warmup time delay function has not timed out yet (verify TSC 9 timer setting) • A loose control connection • Defective generator solenoid • Defective TSC 9 controller (verify output signals with circuit board mounted diagnostic LED’s) • TSC 9 has “Transfer Fail” alarm activated as indicated by flashing Load on Generator LED. Determine cause of alarm and rectify before TSC 9 is reset • If Utility voltage is present, In-phase transfer control has not detected an ‘in-phase condition to permit transfer. Transfer switch will automatically bypass an in-phase transfer after five minutes • There is a phase rotation difference between the Utility and Generator source. Change Power cabling to match both sources phase rotation
<p>Transfer to generator source without a power failure on the utility source</p>	<ul style="list-style-type: none"> • A TEST or EXERCISE mode has been activated (check TSC 9 status LED) • Utility supply voltage is less than 70% on one or both phases of nominal voltage • Verify TSC 9 has correct voltage configuration jumper setting for system voltage • Defective TSC 9 controller (verify output signals with circuit board mounted diagnostic LED’s)

Symptom	Possible Causes
Generator does not start up or stop when it should	<ul style="list-style-type: none"> • Verify remote engine control panel is set for automatic mode • Verify engine start wiring is on correct terminals of TSC 9 controller. • Verify engine start wiring is not loose at transfer switch and/or at the engine control panel.
No time delay when there should be	<ul style="list-style-type: none"> • Verify time delay setting of the TSC 9 controller
Generator Exerciser not operating correctly	<ul style="list-style-type: none"> • Exercise test has been incorrectly cancelled before generator set has operated on load for 60 seconds minimum (refer to manual <i>SECTION 19.9.2</i>). Exercise Alarm condition has been activated (Flashing Alarm LED light and Exercise Light Flashing Fast). Must reset TSC 9 alarm- Press and hold the “E” and “T” pushbutton together for 10 seconds until alarm LED goes out.

22 REPLACEMENT PARTS

Replacement parts are available for the transfer switch as follows:

<p>NOTE</p> <p>When ordering replacement parts please provide the following information:</p> <ul style="list-style-type: none"> -Transfer Switch Model code (e.g. TS 910A100A) -Transfer Switch Serial Number (e.g. MW-022345) <p>The above information can be found on the transfer switch equipment rating plate located on the inside of the ATS door.</p>
--

Part ID	Description
010955	100A, 2 Pole, 240V Power Contactor
010956	200A, 2 Pole, 240V Power Contactor
010957	400A, 2 Pole, 240V Power Contactor
011376	100A, 3 Pole, 240V Power Contactor
011377	200A, 3 Pole, 240V Power Contactor
011243	400A, 3 Pole, 240V Power Contactor
011073	Manual Handle (100A 2P/3P, 200A 2P)
011577	Manual Handle (200A 3P)
011074	Manual Handle (400A Mechanism 2P & 3P)
011069	Limit Switch 1 n/o, 1 n/c (all ATS Models)

NOTE

There are no user serviceable components located on the TSC 9 printed circuit board. If the TSC 9 controller is deemed to be defective it must be returned to the Thomson Power Systems Factory for repair or replacement. Please refer to Product Return Policy section of this manual further information on product return procedures required.

For other parts not listed, please contact Thomson Power Systems.



23 PRODUCT RETURN POLICY

Thomson Power Systems uses a Return Material Authorization (RMA) process. Please complete the Return Authorization Request Form (available on our web page) for return of goods, warranty replacement/repair of defective parts, or credit consideration and fax to the appropriate department.

Returns only: Email sales@thomsonps.com

Warranty replacement/Warranty Repair: Email support@thomsonps.com.

Upon receipt of your request Thomson Power Systems will confirm with a copy of our order acknowledgement, advising the RMA number which should be used to tag the defective controller prior to shipment.





24 NOTES



25 APPENDIX A – TYPICAL AUTOMATIC TRANSFER SWITCH COMMISSIONING PROCEDURES

a) PRE-ENERGIZATION CHECKS

1. Verify the generator and utility supply voltages are 120/240V (or 120/208V 3 Phase or 127/220V 3 phase) maximum.
2. Confirm power cable size is correct for the lugs supplied in the transfer switch (line, load, and neutral) and are properly torqued.
3. Confirm transfer switch has been adequately grounded per NEC requirements.
4. Confirm power cables have been Insulation Resistance Tested to ensure no cross phase connections or conduction to ground.
5. Check for mechanical damage.
6. Check no packaging materials or tools are left inside the transfer switch.
7. Verify control wiring connected to the pluggable terminal block is properly installed (i.e. no frayed ends, screw is tight, no damage, etc.).
8. Ensure TSC 9 Control Isolation Plug (J4) is inserted into the TSC 9 Controller prior to operation.
9. Verify TSC 9 controller jumpers are set to reflect desired operation.
10. Visually verify the transfer switch power contactor is closed in the utility position. The upper solenoid plungers will be pulled towards the upper coils (refer to photos below).

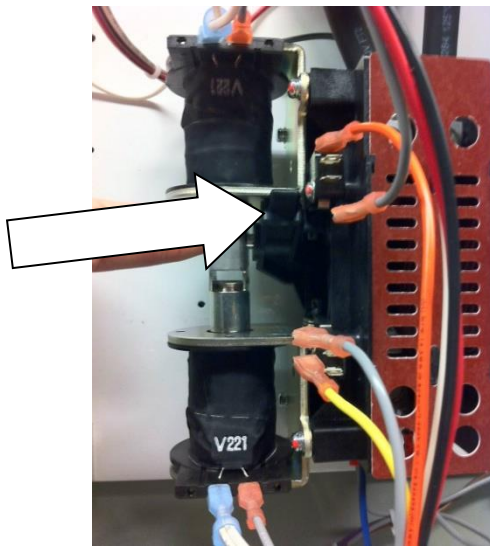

100A/200A Contactor Utility Position

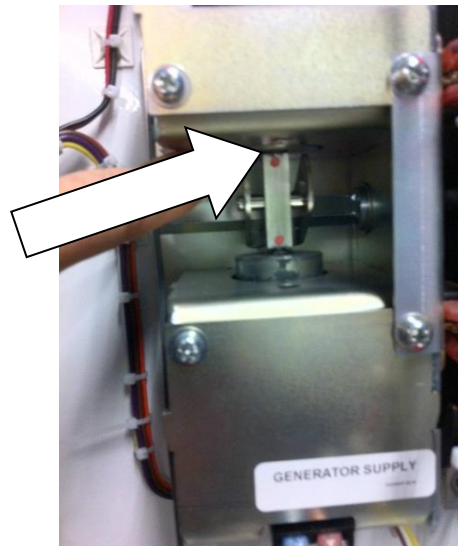

400A Contactor Utility Position

11. Verify correct control wire interconnects have been installed to the generator set auto start/stop controls.

NOTE: The ATS Engine Start contact Closes to start the engine and Opens to stop the engine.

12. Ensure the inside of the transfer switch is clean from all dust, and other foreign materials.

13. Re-install enclosure door front cover and tighten all cover mounting screws.
14. Visually verify on the transfer switch enclosure that there are no gaps, holes, or potential for water ingress.

b) EQUIPMENT ENERGIZATION



DANGER

HAZARD OF ELECTRICAL SHOCK, EXPLOSION, OR ARC FLASH

This equipment must be serviced only by qualified electrical personnel utilizing safe work practices and appropriate Personal Protective Equipment (PPE).

Many components of this equipment operate at line voltage.

DO NOT TOUCH. Use only electrically isolated tools.

Failure to do so may cause personal injury or death

1. Confirm Utility, Generator and loads can be energized in a safe manner.
2. Energize utility supply and confirm voltage is 120/240V (or 120/208V 3 Phase or 127/220V 3 phase) and phase rotation at the utility and load is correct.

NOTE

The Utility supply must be energized before the Generator supply for the System Frequency Auto-Detection feature to work correctly.

3. Verify the status of the following indicator lights on the TSC 9 HMI faceplate:
 - Utility Source Green light is On
 - Load on Utility Green light is On
4. Run the generator manually and confirm generator supply voltage is 120/240V (or 120/208V 3 Phase or 127/220V 3 phase) and phase rotation matches to that of the Utility source and load.

NOTE

On 3 Phase Systems, the TSC 9 controller has Phase Rotation mismatch protection. For the ATS to successfully transfer between sources, both the Utility and Generator Source Phase rotation must be matched. Phase rotation on both sources can be either positive rotation (i.e. A-B-C) or negative rotation (C-B-A)

5. Verify the status of the following indicator lights on the TSC 9 HMI faceplate:
 - Generator Source Red Light is "ON"
6. Using appropriate personal protective equipment (PPE) and insulated tools/meters, remove the transfer switch front cover while energized.
7. Verify at the transfer switch (while energized), the utility and generator supply voltage, phasing and phase rotation is correct.

8. Manually stop generator and place the generator controls in the Automatic position.
9. To confirm automatic starting and load transferring of the generator, perform the following steps:
 - a) To test, press and hold the T pushbutton on the TSC 9 controller faceplate for two seconds until light above pushbutton comes ON. The generator will start and transfer on load per Automatic Sequence.
 - b) To determine correct operation, observe the following on the TSC 9 faceplate:
 - Gen Start Red light is On
 - Gen Source Red light is On
 - Load on Gen Red light is On
10. To stop the generator and transfer load back to the utility supply, press and hold the T pushbutton for two seconds until light above pushbutton goes OFF. The load will re-transfer back to the utility power as per Automatic Sequence.
11. Perform a utility power outage test by opening the upstream utility feeder breaker. The TSC 9 controller Utility supply light will turn off; the generator set will start after the three-second engine start delay has expired, the generator should start and transfer on load as per Automatic Sequence.
12. Return the transfer switch to utility power by re-closing the upstream utility breaker. The load should re-transfer back to the utility supply as per Automatic Sequence.



Thomson Power Systems

4916 - 275 Street

Langley, BC, Canada V4W 0A3

Customer Support: 604-888-0110

Toll Free: 1-888-888-0110

General Inquiries Email: info@thomsonps.com

Sales Email: sales@thomsonps.com

Service Email: support@thomsonps.com

www.thomsonps.com

For Preventative Maintenance or Extended Warranty information contact our Service Department at 604-888-0110 or email support@thomsonps.com



Note: Specifications subject to change without notice.

Thomson Power Systems and Regal are trademarks of Regal Beloit Corporation or one of its affiliated companies.

©2018 Regal Beloit Corporation, All Rights Reserved. PM 147r4 21/10/23

