



OPERATION, MAINTENANCE, AND INSTALLATION GUIDE

Zenith ZTX series

For ZTX series automatic transfer switches, 30-1200 A, 200-480 Vac



Receiving, handling and storage

**Warning**

Indicates a hazardous situation that, if not avoided, could result in death or serious injury.

**HAZARD OF EQUIPMENT
OVERTURNING**

When moving with a fork lift, do not remove the shipping packaging until the device is in its final location.

Failure to follow this instruction may result in personal injury or equipment damage.

Receiving and handling

Upon receipt, carefully inspect the transfer switch for damage that may have occurred during transit. If damage is evident, or there is visible indication of rough handling, immediately file a damage claim with the transportation company, and notify your local ABB sales office.

Do not remove the shipping packaging until ready to install the switch.

Storage

If the unit will not be placed into service immediately, store the transfer switch in its original package in a clean, dry location. To prevent condensation, maintain a uniform temperature. Store the unit in a heated building, allowing adequate air circulation and protection from dirt and moisture. Storing the unit outdoors could cause harmful condensation inside the transfer switch enclosure.

Read these safety instructions carefully before using this product!

**Danger**

Indicates a hazardous situation that, if not avoided, will result in death or serious injury.

HAZARD OF ELECTRIC SHOCK, EXPLOSION, OR ARC FLASH

- Apply appropriate personal protective equipment and follow safe electrical work practices.
- This equipment must only be installed and serviced by qualified electrical personnel.
- Before performing visual inspections, tests, or maintenance on the equipment, disconnect all sources of electric power. Assume that all circuits are live unless they are completely de-energized, tested, grounded, and tagged. Pay particular attention to the design of the power system. Consider all sources of power, including the possibility of backfeeding.
- Disconnect all sources of electric power before removing or making source side or load side connections to the transfer switch.
- Always use a properly rated voltage sensing device at all line and load connections to confirm transfer switch is disconnected from all live electrical sources.
- Turn off power supplying transfer switch before doing any other work on or inside switch.

Failure to follow these instructions could result in death or serious injury.

Operation, maintenance, and installation instruction

Automatic transfer
switches, Zenith ZTX
series ATS

OPERATION AND MAINTENANCE
INSTRUCTIONS, ZENITH
ZTX SERIES ATS,
CHAPTERS 1–8

INSTALLATION INSTRUCTIONS,
ZENITH ZTX SERIES ATS,
CHAPTERS 9–11

1

2

Operation and maintenance instruction

Automatic transfer switches, Zenith ZTX series ATS

1. Introduction	11
1.1 Hazard Categories	11
1.2 Definitions	12
1.3 Warranty	13
1.4 Product Specification	14
2. Product overview	15
2.1 General overview	16
2.1.1 Operation types	17
2.2 HMI	18
2.3 Zenith ZTX series features	19
2.4 Typical applications	22
2.5 Sequence of operations	24
2.5.1 Switching sequence / Automatic	24
2.6 Special features description	26
2.6.1 Automatic configuration	26
2.6.2 In-phase monitor	26
2.6.3 Powering supply scenarios	26

3. General operation	27
3.1 Position indication	27
3.2 Operating and locking	28
3.3 Manual handle operation	29
3.4 Return to automatic mode, operating by HMI	30
3.5 LED functionality in HMI	31
3.6 Using Level 2 (DIP) control interface HMI	33
3.6.1 Keypad	33
4. Navigating HMI menu	35
4.1 Configuration by DIP switch	35
5. Electronic accessories	37
5.1 Using Ekip Connect -software	38
5.2 Using Ekip Bluetooth-module	39
5.2.1 LED indications	39
5.3 Using Ekip Programming -module	40
5.3.1 LED indications	40

6. Troubleshooting	41
6.1 Alarms	41
6.2 Warnings	43
6.3 Information	44
7. Technical data	45
7.1 General technical data	45
7.2 Circuit diagrams	48
7.3 Overall dimensions	49
8. Maintenance	53

1. Introduction

This manual describes the installation, basic operation, and maintenance of the Zenith ZTX series (30-1200A, 200-480Vac) automatic transfer switches, manufactured by ABB. Installation instructions for the transfer switch and available accessories can be found in chapters 9 and 10.

1.1 Hazard Categories

The following important highlighted information appears throughout this document to warn of potential hazards or to call attention to information that clarifies a procedure.

Carefully read all instructions and become familiar with the devices before trying to install, operate, service or maintain this equipment.



Danger

Indicates a hazardous situation that, if not avoided, will result in death or serious injury.



Warning

Indicates a hazardous situation that, if not avoided, could result in death or serious injury.



Caution

Indicates a hazardous situation that, if not avoided, could result in minor or moderate injury. Failure to comply with these instructions may result in product damage.



Notice

It is used to notify of practices not related to personal injury. Failure to comply with these instructions may result in product damage.

1.2 Definitions

1

ATS

Automatic transfer switches

Ekip

Electronic accessories / Ekip-modules

HMI

Control interface (Human Machine Interface), operating and configuration

Programming port

Only for Ekip Programming and Ekip Bluetooth -modules (USB port)

Slide switch

Switch for operating mode selection (Hand - Locking - AUTO)

S1

SOURCE 1, power supply

S2

SOURCE 2, power supply

Zenith ZTX series ATS

Small frame residential, commercial, & light industrial enclosed automatic transfer switches, product name

1.3 Warranty

This document is based on information available at the time of its publication. While efforts have been made to ensure accuracy, the information contained herein does not cover all details or variations in hardware and software, nor does it provide for every possible contingency in connection with installation, operation, and maintenance. Features may be described herein that are not present in all hardware and software systems.

ABB Zenith assumes no obligation of notice to holders of this document with respect to changes subsequently made. ABB Zenith makes no representation or warranty, expressed, implied, or statutory, and assumes no responsibility for the accuracy, completeness, sufficiency, or usefulness of the information contained herein. No warranties of merchantability or fitness for purpose shall apply.

Contact your local sales office if further information is required concerning any aspect of the automatic transfer switch operation or maintenance.

Warranty Period

The Warranty Period for ZTX series transfer switch products is twelve (12) months from the date of shipment.

Notes: This warranty is valid only in the United States and for products sold and installed within seller-specified countries.

Replacement parts are warranted for a period of 90 days when installed by a factory or an authorized service station.

Contact Service team at: +1 800 637 1738

1.4 Product Specification

Quality Assurance

All ABB Zenith automatic transfer switches have been designed and manufactured to the highest technical standards. Strict procedures ensure first-class product quality.

Product Serial Number

Please have the serial number available when communicating about the automatic transfer switch. The serial number can be found on the product nameplate affixed to each power panel assembly. See example below.

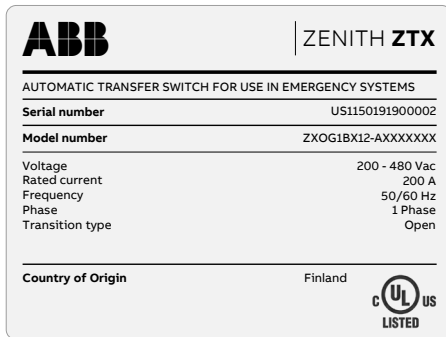

Figure 1.1: Sample nameplate

Product Rating / Applicable Standards

For UL 1008 'withstand' and 'close on short circuit' ratings, refer to ABB publication number 1SCC303020C0201, "Zenith ATS, Powered by TruONE(TM) Withstand and Closing Ratings (WCR)"

2. Product overview

Zenith ZTX series automatic transfer switches, from 30 A up to 1200 A, are designed for use in residential, commercial, & light industrial low voltage automatic transfer switch applications. Zenith ZTX series automatic transfer switches can be operated electrically by DIP control interface (HMI) or manually by using the handle. You can select the operating mode by the slide switch (Hand - Locking - AUTO) on switch front. Configuration is done by DIP HMI.

The available operation types for automatic transfer switches:

- Open (standard) transition Zenith ZTX series ATS, type codes beginning ZXO_ from 30-1200 A, 200-480 Vac

2.1 General overview

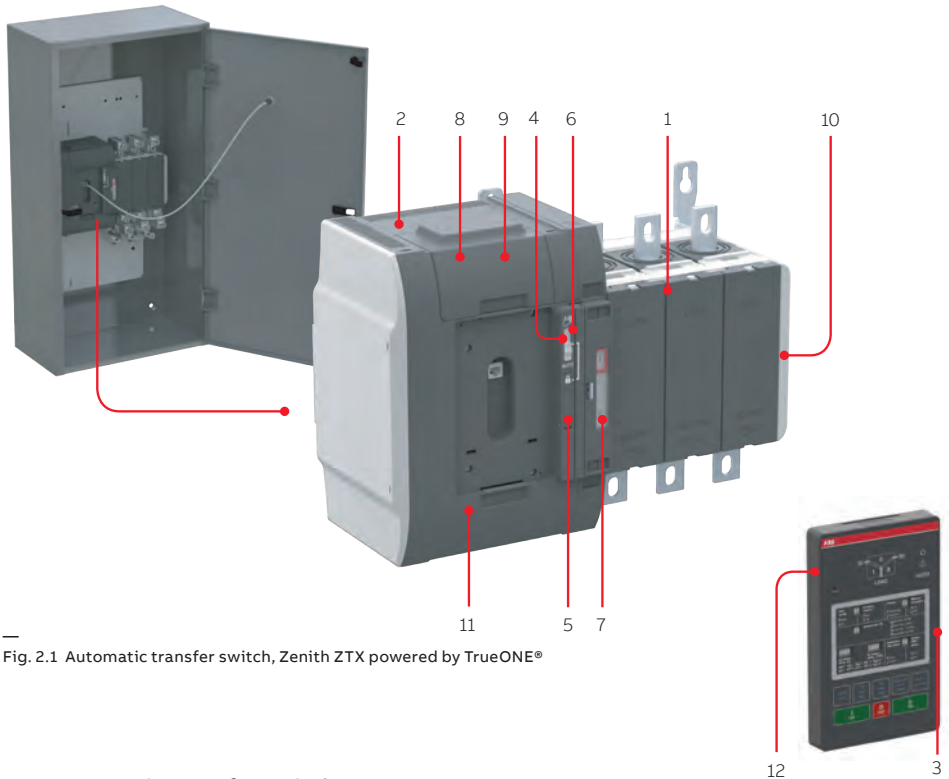

Fig. 2.1 Automatic transfer switch, Zenith ZTX powered by TrueONE®

- 1 Automatic transfer switch
- 2 Embedded ATS control unit and mechanism
- 3 HMI unit (ZTX DIP)
- 4 Slide switch (Hand - Locking - AUTO) for selection of the operation mode
- 5 Padlocking the automatic transfer switch to prevent automatic and manual operation
- 6 Handle for manual operation
- 7 Position indication
- 8 Terminals for control circuit connections (behind the cover)
- 9 Place for auxiliary contact block
- 10 Location of product identification label
- 11 Programming port, only for Ekip Programming module and Ekip Connect software

2.1.1 Operation types

In this table you can find the details on the ZTX series operation type. For more information on HMIs, see chapter 2.2 and for wiring, see chapter 7.



<p>Operation types, ZTX series ATS</p> <p>Open transition, ZTX</p> <p>S1 I II S2</p>  <p>Load</p>	<p>Ekip-modules suitable</p>
<p>ZTX series HMI (with DIP-switches) and connections of control circuit</p>	
 	<p>Not Suitable</p> 

Table 2.1 The differences of level types / operation types and the suitability of Ekip-modules

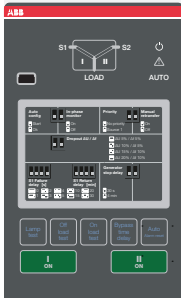
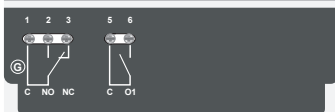

2.2 HMI

The HMI is the control interface (Human Machine Interface) of the ATS.

Zenith ZTX series has a DIP switch HMI with push buttons. The HMI is used for configuring parameters for automatic operation.

ZTX:
HMI with
DIP switches

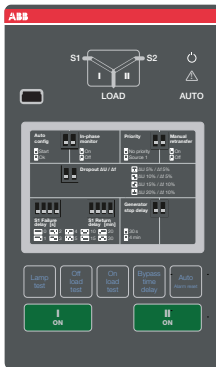

I - II (or II - I)

Fig. 2.2 HMI type

2.3 Zenith ZTX series features

Feature comparison

ZTX controls (DIP)



Ampere sizes available	UL: 30-1200 A
Rated voltage	200-480 Vac
Rated frequency	50 / 60 Hz
Phase system	Single and Three
Number of poles	2, 3 and 4
Neutral configuration	
Switched	Yes
Product type	
Open transition (I-II)	Yes
Voltage and frequency settings	
Pick up Voltage Source 1	Fixed 2% above drop out
Drop out Voltage Source 1	+/-5, 10, 15, 20 %
Pick up Voltage Source 2	Fixed 2% above drop out
Drop out Voltage Source 2	+/-5, 10, 15, 20 %
Pick up Frequency Source 1	Fixed 1% above drop out
Drop out Frequency Source 1	+/-5, 10 %
Pick up Frequency Source 2	Fixed 1% above drop out
Drop out Frequency Source 2	+/-5, 10 %
Time delay settings	
Override momentary Source 1 Outage, sec	0, 1, 2, 3, 4, 5, 10, 15, 20, 30
Transfer from source 1 to source 2, sec	2 (0-3600 via Ekip Connect)
Override momentary Source 2 Outage, sec	1,5 (0-60 via Ekip Connect)
Transfer from source 2 to source 1, min	0, 1, 2, 3, 4, 5, 10, 15, 20, 30
Generator stop delay, min	30 secs or 4 mins

Feature comparison

ZTX controls (DIP)



Source failure detections

No voltage	Yes
Undervoltage	Yes
Overvoltage	Yes
Phase missing	Yes
Voltage unbalance	Yes
Invalid frequency	Yes
Incorrect phase sequence	Yes

Features

Controls	DIP + keys
LED indications for ATS, S1 and S2 status	Yes
Open transition - Standard digital inputs/outputs	0 / 1
Programmable digital inputs/outputs	No
Auto config (voltage, frequency, phase system)	Yes
Source priority	Source 1, No priority
Manual retransfer	Yes
In-phase monitor (synchro check)	Yes
Genset exercising: on-load, off-load	Yes, via Ekip Connect
Load shedding	No
Real time clock	Yes
Event log	Yes, via Ekip Connect
Predictive maintenance	No
Harmonics measuring	No

Feature comparison**ZTX controls (DIP)****Field-mount accessories**

Auxiliary contacts for position indication	Yes
Digital input/output modules	No
12-24 Vdc aux supply module for controller	No
Communication modules	No

For applications

Mains ¹⁾ - Mains	Yes
Mains - Generator ²⁾	Yes

¹⁾ Mains may also be referred to as Utility or Transformer.

²⁾ Contact ABB for applications with smaller than 20 kVA gensets.

—
Table 2.2 ATS features not limited to what is in the table above

2.4 Typical applications

1

Zenith ZTX series automatic transfer switches from 30 A up to 1200 A, are designed for use in emergency or standby systems to choose and to switch between two power sources. See possible supply phase scenarios on next page. You have to define your own supply phase system - reference Chapter 4 / Navigating menu / Parameters: Power distribution systems. Factory setting: 3 phases with neutral.

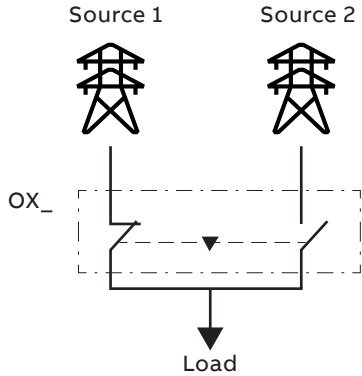
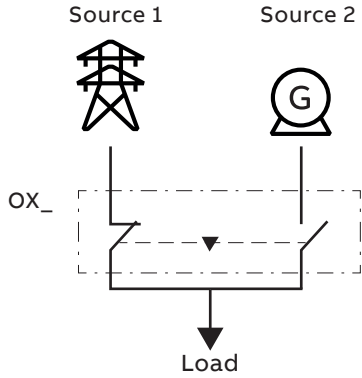
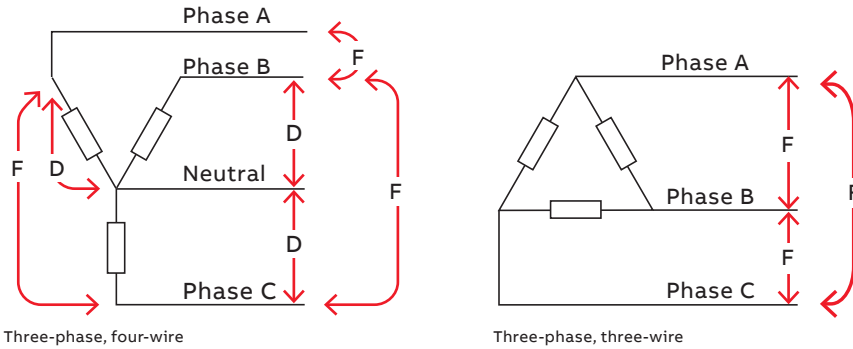
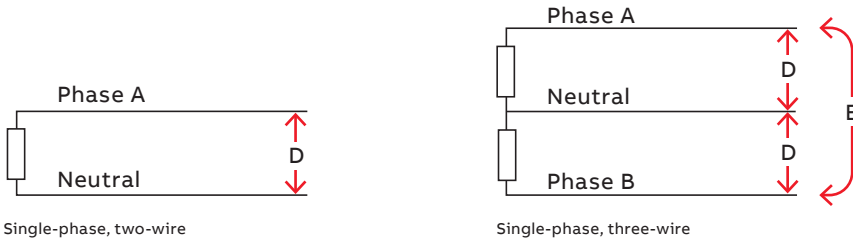
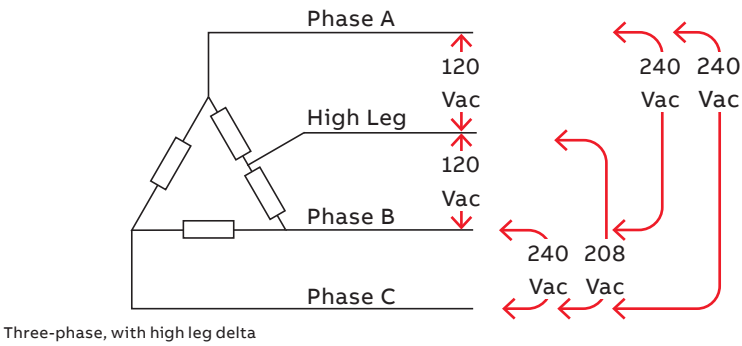

Fig. 2.3 Typical applications of automatic transfer switches



D	E	F
200-480 Vac L-N	200-480 Vac L-L	200-480 Vac L-L



A07482

Fig. 2.4 Possible supply phase scenarios

2.5 Sequence of Operations

1

2.5.1 Switching sequence / Automatic

2.5.1.1 SOURCE 1 Priority (SOURCE 2 = Generator)

The switching sequence can be summarized in the following steps:

- An anomaly occurs on SOURCE 1
- Override momentary S1 outage delay
- Generator start
- SOURCE 2 OK
- Transfer from S1 to S2 delay
- Transfer switch (SOURCE 2) to position II

The re-transfer sequence can be summarized in the following steps:

- SOURCE 1 is restored
- Transfer from S2 to S1 delay
- Transfer switch (SOURCE 1) to position I
- Generator stop delay
- Generator stop
- SOURCE 2 off

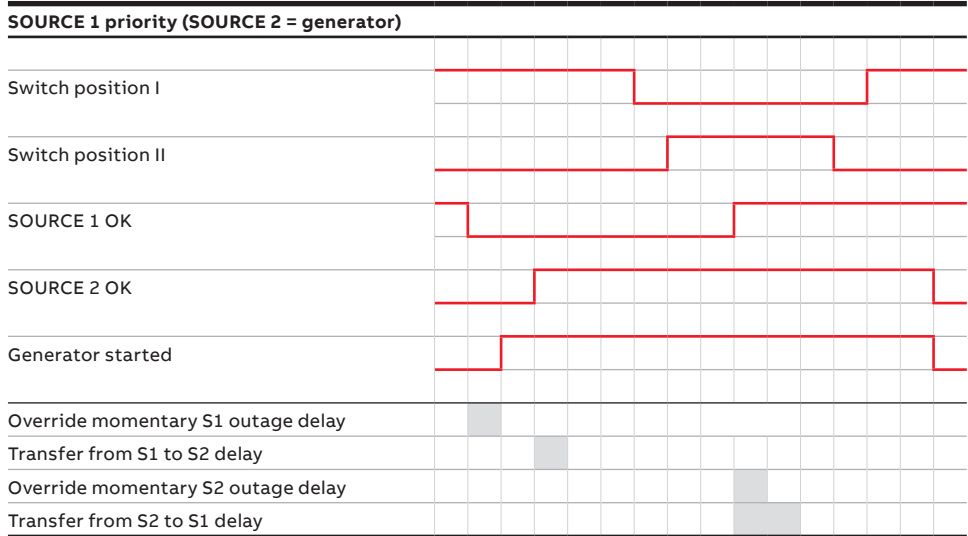

Table 2.3 Automatic Switching Sequences, SOURCE 1 Priority (SOURCE 2 = Generator)

2.6 Special features description

2.6.1 Automatic configuration

Basic system parameters can be automatically configured from the HMI: rated voltage, rated frequency, each supply power distribution system type, and neutral location will be recognized and set by the controller. Other parameters are set to factory values; see Chapter 4, Navigating menu.

2.6.2 In-phase monitor

In-phase monitor is a feature that calculates the phase difference of supply lines, preventing transfer when sources are not in sync. The user can set On/Off from the HMI. When the in-phase monitor is set to On, the device measures and detects when both sources are in sync with each other. The ATS will allow transfer from SOURCE 1 (S1) to SOURCE 2 (S2) only when they are in sync with each other. Any of these conditions will prevent source transfer when In-phase monitor is set to On:

- Phase difference between sources remains greater than 5 degrees
- Phase order between sources is not the same
- Voltage amplitude is out of range
- Phase is missing
- Voltage is asymmetric
- Frequency is out of range

2.6.3 Powering supply scenarios

Device can be powered by the the following methods:

- Direct from SOURCE 1 or SOURCE 2: Controller and HMI are powered and ATS can be operated electrically.
- Programming port on HMI (USB port): Only the main board is powered. Allows software update to main device and connection of Ekip Connect commissioning tool.

3. General operation

3.1 Position indication

Contact movement and position indication is indicated in the figure below, open transition I - II (or II - I).



ZTX I - II

Fig. 3.1 Contact movement / position indication:
Type ZTX, Open transition

3.2 Operating and locking

The operation mode is selected by using the slide switch (Hand - Locking - AUTO) located on the front of the automatic transfer switch (ATS).

- **Hand-position = Manual mode**, enabling emergency manual operation using the handle. ATS functionality is disabled when in Hand position.
- **Lock-position = Locking mode**, padlocking the automatic transfer switch in a specific position to prevent automatic and manual operation.



Notice

The handle has to be in its stored position (not in use), after which the slide switch will move to the Locking mode automatically and the switch is allowed to be padlocked. To set the operating handle back to its place, refer to the left most picture in Fig. 3.6.

- **AUTO-position = Automatic control mode enabled**, ATS is operable in Automatic mode or from the HMI manual control keys. When the slide switch is moved to the AUTO position, the ATS is functioning immediately in the automatic control mode.



Manual mode

Automatic mode

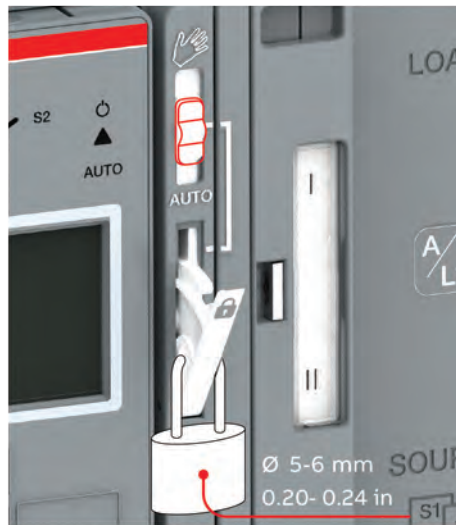

Locking mode

Fig. 3.2 Above the selection of the operation modes (Manual or Automatic) by the slide switch. Below padlocking the automatic transfer switch; The handle has to set standby slot (not in use), after that the slide switch will move to the Locking mode automatically and the switch is allowed to be padlocked.

3.3 Manual handle operation



Warning

Verify the condition of power source prior to manually transferring. Manual operation may result in out-of-phase transfer when both sources are energized.

To mount the handle in the operating position, turn the slide switch to the Manual mode (Hand), lift the handle from its place inside and place it to the operating position.

More information, see animation: Manual and automatic operation - TruONE® ATS (<https://youtu.be/bosvSPVi2sM>).



Fig. 3.3 Mounting of the handle in the operating position

1

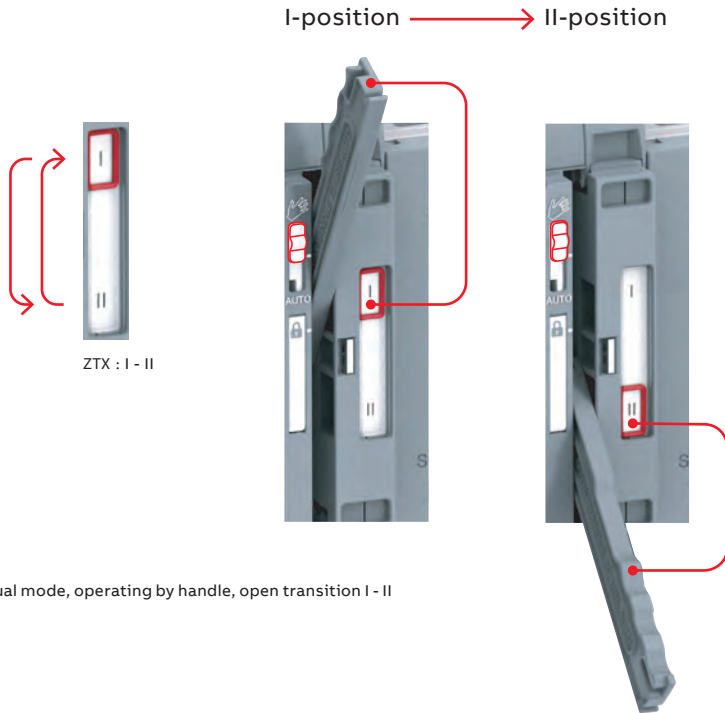

Fig. 3.4 Manual mode, operating by handle, open transition I - II

3.4 Return to Automatic mode, operating by HMI

When operating the automatic transfer switch by HMI, turn the slide switch to Automatic mode (AUTO).



Notice

The handle has to be standby slot (not in use) before turning to automatic mode.

When the slide switch is moved to the AUTO position, the ATS will enter auto mode after a 3 second delay.

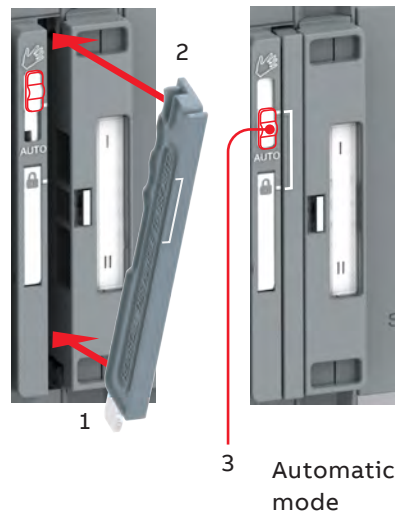
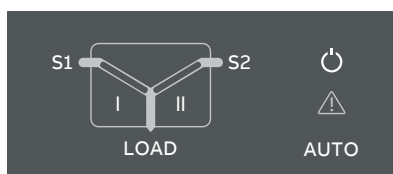

Fig. 3.5 The operating handle must set back to standby slot before moving to the automatic mode

3.5 LED functionality in HMI



At the top of ZTX 30-1200 A, 200-480 Vac ATS, there is a set of LEDs intended to model the state of the transfer switch sources, position, alarms, and mode. A considerable amount of information can be deciphered from the LED states. See the tables below for more information.



I - II

Fig. 3.6 LEDs in ZTX, open transition I - II.

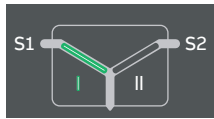
LED	Indication	Description
Power led		
	ON, fixed light	Power supply and communication present
	2 quick flashes/1s	Power supply present, communication absent between switch and the HMI
	OFF	No power available for HMI.
S1 and S2 leds		
	ON, fixed light	S1 or / and S2 is present and within user defined limits
	2 quick flashes/1s	Undervoltage
	Flash/1 s, 90%/10 %	Invalid frequency
	Flash/1 s, 10%/90 %	Unbalance
	5 flashes/1 s, 50%/50 %	Overvoltage
	Flash/2 s, 50%/50%	Incorrect phase sequence
	Flash/4 s, 50%/50 %	Phase missing
	Flash/1 s, 50%/50 %	Generator stop delay ongoing
OFF	No voltage	

I and II ledsON, fixed light 

Switch position is indicated with fixed light in I, O or II led. Only one can be on simultaneously

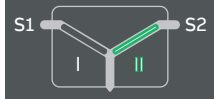
Flash/1 s, 50%/50 % 

Delay ongoing. Going to move away from the blinking status

Load ledON 

Supply ok and connected to load

OFF 

Not connected to load

Auto ledON, fixed light 

Switch is in automatic mode

Flash/1 s, 50%/50 % 

Test on load

Flash/1 s, 90%/10 % 

Test off load

5 flashes/1 s, 50%/50 % 

Autoconfig completed

Alarm ledOFF 

No alarms

ON, fixed light 

Handle attached, locked, other alarm

2 quick flashes/1s 

Control Alarm

5 flashes/1 s, 50%/50% 

Auto configuration ongoing

Flash/1 s, 50%/50% 

Control Retry

Flash/1 s, 10%/90% 

Auto mode off

Table 3.1 LED functionality

3.6 Using Level 2 (DIP) control interface HMI

3.6.1 Keypad

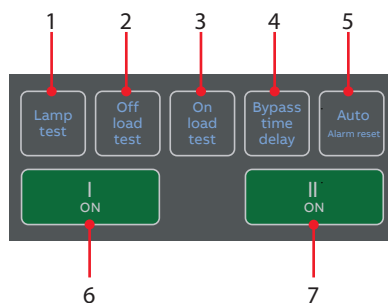

ZTX_, open transition, I - II

Fig. 3.7 Keypad HMI with DIP-switches

- 1 **Lamp test:** Turns on all LEDs simultaneously to confirm all LEDs are operational
- 2 **Off load test:** Initiates off load test (Starts generator but does not transfer the load to the generator)
- 3 **On load test:** Initiates on load test (Starts the generator and transfers the load to the generator)
- 4 **Bypass time delay:** Bypass any currently running time delay
- 5 **Auto (Alarm reset):** In the event of active switch control alarm (open I failure, close I failure, open II failure, close II failure), resets to no alarm state. If no active alarms, toggle between automatic/HMI control modes
- 6 **I ON:** Operate switch to I position
- 7 **II ON:** Operate switch to II position



4. Navigating HMI

4.1 Configuration by DIP switch

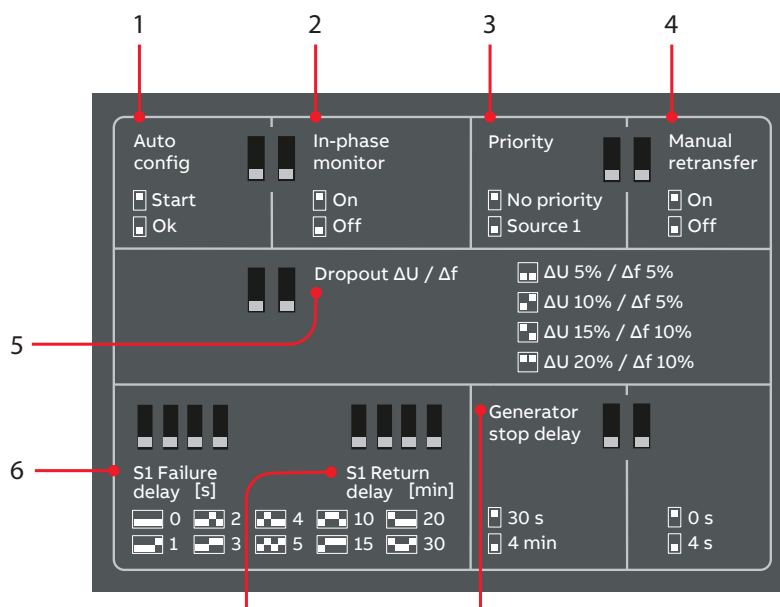

Fig. 4.1 DIP-switches for configuration in ZTX HMI

- 1 Auto config:** Automatically detecting Source 1 and Source 2 parameters. Automatic configuration sequence is started by setting DIP to 'Start' position. Parameter detection is ready when AUTO LED flashes 5 times in 1 second. After this the DIP must be set to 'Ok' position to resume normal operation. Check power supply of the voltage source in case the Alarm LED keeps flashing instead of AUTO LED. This indicates that system parameters cannot be detected from the supplied voltage.
- 2 In-phase monitor:**
 On: Enable in-phase monitor
 Off: Disable in-phase monitor
- 3 Priority:**
 No priority: Application 'Two Transformers / No Priority' selected.
 Source 1: Application 'S1-Transformer / S2-Generator' selected.

4 Manual retransfer:

On: Manual retransfer to priority source enabled (automatic retransfer disabled)

Off: Manual retransfer to priority source disabled (automatic retransfer enabled)

5 Dropout ΔU^1 / ΔF :

Dropout voltage/frequency limit.

For example 5 % / 5 %:

Voltage source is considered acceptable when measured voltage is in range 0.95 - 1.05 nominal Voltage (U_n) * U_n and measured frequency is in range 0.95 - 1.05 x nominal frequency (f_n).

6 S1 Failure delay: The time (0/1/2/3/4/5/10/15/20/30 s) device waits after priority source failure before starting automatic transfer sequence from priority source to non-priority source.

7 S1 Return delay: The time (0/1/2/3/4/5/10/15/20/30 min) device waits after priority source return before starting automatic retransfer sequence from non-priority source to priority source.

8 Generator stop delay: The time (30 s or 4 min) device waits after transferring back to priority source before stopping the generator.

**Notice**

¹ U is also commonly known as V.

5. Electronic accessories

**Warning**

Hazardous voltage may be present within the panel when connecting electronic accessories. Remove all sources of power to the ATS panel before connecting Ekip modules.

Ekip Connect Software and Bluetooth and Programming -modules are suitable for all ZTX 30-1200 A, 200-480 Vac automatic transfer switches, refer to chapters 5.1...5.3. for more details on:

- Ekip Connect -software
- Ekip Bluetooth -module
- Ekip Programming -module

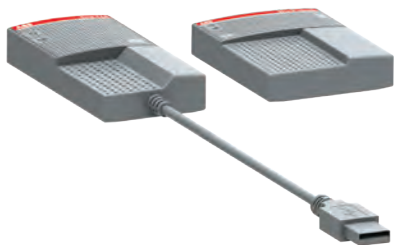

Fig. 5.1 Programming and bluetooth -modules

5.1 Using Ekip Connect -software

1

Ekip Connect is a free software for communication and testing of ABB automatic transfer switches. The software is compatible with ZTX 30-1200 A, 200-480 Vac automatic transfer switches. It can be installed on PCs equipped with the Microsoft Windows® operating system. To download it, see the address below: <http://www.abb.com/abblibrary/DownloadCenter/>

With its communication function, it allows you to:

- Monitor the state of the automatic transfer switches connected and record information.
- Configure the automatic transfer switches with customized parameters.
- Create communication reports.
- Reset configurations.

Further information on the Ekip Connect application is available from the web site, see the address below, particularly the manual 1SDH000891R0002.

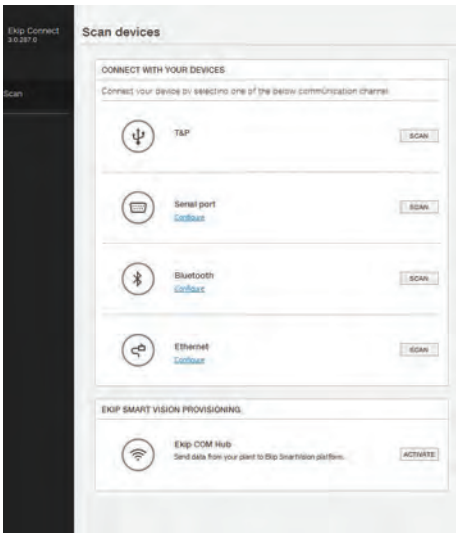

Fig. 5.2 Ekip Connect -software

5.2 Using Ekip Bluetooth-module

The Ekip Bluetooth module allows connection via Bluetooth between the automatic transfer switch and a support device (PC, tablet, or smart phone) with the Ekip Connect software installed. Ekip Bluetooth -module is suitable to use with all ZTX 30-1200 A, 200-480 Vac automatic transfer switches.

The Ekip bluetooth module draws its power from a rechargeable lithium-polymer battery supplied with the unit. It is connected directly to the programming port (see Fig. 5.6) powers the controller without the need for auxiliary voltage supply. The programming port is only compatible for use with Ekip Bluetooth and Ekip Programming -modules.

5.2.1 LED indications

Ekip Bluetooth -module is switched on by pressing the power button on the side, and is equipped with two LEDs:

- The first LED illuminates in green with the device on and the battery charge, red with the device turned on and low battery.
- The second LED flashes blue with active Bluetooth communication.

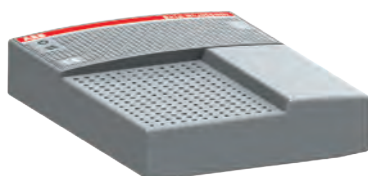

Fig. 5.3 Ekip Bluetooth-module

5.3 Using Ekip Programming -module

The Ekip Programming -module is suitable to use with all ZTX 30-1200 A, 200-480 Vac automatic transfer switches. You can connect the module via the programming port, see Fig. 5.5. The programming port is only compatible for use with Ekip Programming and Ekip Bluetooth -modules.

Ekip Programming -module allows you to:

- With Ekip Connect software update the software and load, set and read the parameters

The Ekip Programming -module draws its power from the PC and connects one side directly to the programming port (see Fig. 5.6) and on the other to the USB port of the PC with the cable supplied.

5.3.1 LED indications

Ekip Programming -module turns on after connecting to the PC, and is equipped with two LEDs. The first, illuminates green indicating that the module is on, and the second, illuminates yellow indicating active communication.



Fig. 5.4 Ekip Programming -module



Fig. 5.5 Programming port (USB port) is situated in the front of the HMI, on left side

6. Troubleshooting



Warning

Any troubleshooting should be conducted by trained and authorized personnel only. Appropriate personal protective equipment (PPE) shall be used when troubleshooting the ATS panel. Hazardous voltage may be present. Disconnect all power sources before performing work inside the ATS panel. Failure to do so may result in serious injury or death.



Notice

Alarms, warnings, and information are directly viewable only via Ekip Programming or Bluetooth modules

6.1 Alarms

Alarm condition	Fault	Action
Locked, Alarm LED on	Lock input activated	Unlock
Switch not in AUTO mode, Alarm LED on	Slide switch is in handle or lock position	Turn slide switch into the AUTO position
Phases crossed	Phase rotation of sources 1 and 2 are different	Connect the phases of both sources in the same order
S1 undervoltage	Voltage of source 1 is under the threshold level set in parameter "Dropout voltage, lower threshold"	Check the correlation between power source and device configuration
S1 overvoltage	Voltage of source 1 is over the threshold level set in parameter "Dropout voltage, upper threshold"	Check the correlation between power source and device configuration
S1 phase missing	One or two phases of source 1 are missing	Check the power source and connections
S1 unbalance	Phases of source 1 are not symmetric	Check the power source
S1 phase rotation	Phase rotation of source 1 is different from the value of parameter "Phase sequence"	Connect the phases according to the configuration

Table 6.1 Alarms-list in ZTX via Ekip Connect

Alarm condition	Fault	Action
S1 invalid frequency	Frequency of source 1 is out of range set in parameters "Drop-out frequency, upper threshold" and "Drop-out frequency, lower threshold"	Check the correlation between power source and device configuration
S2 undervoltage	Voltage of source 2 is under the threshold level set in parameter "Dropout voltage, lower threshold"	Check the correlation between power source and device configuration
S2 overvoltage	Voltage of source 2 is over the threshold level set in parameter "Dropout voltage, upper threshold"	Check the correlation between power source and device configuration
S2 phase missing	One or two phases of source 2 are missing	Check the power source and connections
S2 unbalance	Phases of source 2 are not symmetric	Check the power source
S2 phase rotation	Phase rotation of source 2 is different from the value of parameter "Phase sequence"	Connect the phases according to the configuration
Frequency Difference	Frequency difference of voltage sources is greater than 3 Hz while inphase monitor is on	Alarm is active and transfer operations disabled as long as the frequency difference is above the accepted level
S2 invalid frequency	Frequency of source 2 is out of range set in parameters "Drop-out frequency, upper threshold" and "Drop-out frequency, lower threshold"	Check the correlation between power source and device configuration
Open I failure, Alarm LED blinking	Switch transfer from position I to O or II failed	Reset alarm by pressing Auto button or via menu page Operation / Alarm Reset
Close I failure, Alarm LED blinking	Switch transfer to position I failed	Reset alarm by pressing Auto button or via menu page Operation / Alarm Reset
Open II failure, Alarm LED blinking	Switch transfer from position II to O or I failed	Reset alarm by pressing Auto button or via menu page Operation / Alarm Reset
Close II failure, Alarm LED blinking	Switch transfer to position II failed	Reset alarm by pressing Auto button or via menu page Operation / Alarm Reset
Switch position alarm, Alarm LED on	More than one switch position indication inputs are activated	Switch service needed, contact ABB
Local bus	Communication between HMI and switch controller is off	Check connection
Control Voltage Failure	Control voltage dropped during switch control	Check power source
Control Voltage Low	Switch control voltage is below the minimum	Check power source
Configuration Error	Invalid configuration	Check parameter values

Table 6.1 Alarms-list in ZTX via Ekip Connect

6.2 Warnings

Message	Reason
S1 and S2 not in sync	Voltage sources are not synchronized
Voltage Not Calibrated	Calibration data in power module is invalid or unavailable, contact ABB
Current Not Calibrated	Calibration data in current measurement module is invalid or unavailable, contact ABB
Pole temperature warning	Measured pole temperature is near the alarm level
Control Retry	Failed transfer sequence retry activated
Auto Control Disabled	Device is in manual operating mode
Local Bus	Module heartbeat error
Configuration	Configuration session ports are open
RTC capacitor charging	Real time clock is not yet operational, date & time setting is disabled as long as this warning is active. RTC capacitor is charged from source voltage (not AUX) and takes about 10 minutes.

Table 6.2 Warnings-list in ZTX via Ekip Connect

6.3 Information

1

Message	Description
Invalid Date	Date not set
Test on Load	Test on load sequence active
Test off Load	Test off load sequence active
Alarm/Product Availability	Digital output function activated
In Position I	Digital output function activated
In Position II	Digital output function activated
Source 1 Available	Digital output function activated
Source 2 Available	Digital output function activated

Table 6.3 Info statements in ZTX via Ekip Connect

7. Technical data

7.1 General technical data

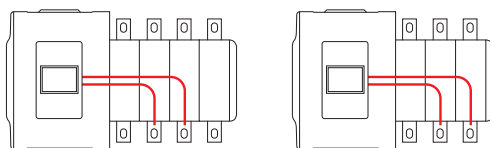
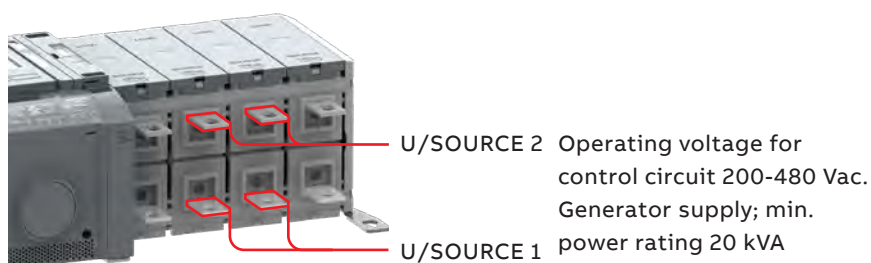
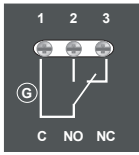
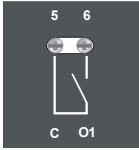

Fig. 7.1 Power supply for control and power switching circuits

Automatic transfer switch, power circuit	Value	
Rated operational voltage U	200-480 Vac	
Rated frequency f	50 / 60 Hz	
Rated impulse withstand voltage U_{imp}	12 / 8 kV	
Operating times	See Table 7.2	
Automatic transfer switch, control circuit	Value	Remark
Voltage supply	200-480 Vac	Integrated, see Fig. 7.1
Operating voltage range	±20%	
Voltage measurement accuracy		
Rated frequency f	50 / 60 Hz	
Operating frequency range	±20%	
Frequency measurement accuracy		
Rated impulse withstand voltage U_{imp}	6 kV	

Automatic transfer switch, I/O contacts	Cabling / Terminal	Rating / Remark
Generator start/stop	24-14 AWG	Stripping length; 0.255"
 Common, voltage supply	1	5 A@250 Vac (AC-1), 5 A@30 Vdc
Generator start/stop NO	2	
Generator start/stop NC	3	
Output relay features	24-14 AWG	
 Common, voltage supply	5	5 A@250 Vac (AC-1), 5 A@30 Vdc
Programmable output (default; Product available)	6	

AC15		AC12			AC13	
Ue/[V]	Ie/[A]	Ue/[V]	Ie/[A]	P/[W]	Ie/[A]	P/[W]
230	6	24	10	240	2	50
400	4	72	4	290	0.8	60
415	4	125	2	250	0.55	70
690	2	250	0.55	140	0.27	
		440	0.1	44		

Table 7.1 Technical data for auxiliary contacts according to IEC 60947-5-1, for OA1G_, OA3G_

Recommended Operating / Storage Temperature

Do not store the automatic transfer switch in corrosive environments above LC1 (sea salt mist) and G1 as per ANSI/ ISA-S71.04-1985. Failure to comply with these instructions may result in product damage. Store the automatic transfer switch and related accessories in a clean, dry location in their original packaging.

Environmental	Value
Environments category	E
EMC environment	Environment A
Operating temperature (without derating)	-20 - +40 °C
Operating temperature (with derating)	-25 - +70 °C
Transportation and storage temperature	-40 - +70 °C
Altitude (without derating)	Up to 2000 m

Table 7.2 General technical data of automatic transfer switch

Type	Voltage [Vac]	Nominal current* [A]	Operating transfer time ^{1, 2} AUTO mode I-II or II-I [ms]	Contact transfer time ¹ I-II or II-I [ms]
ZTX 30 - 260A	200 - 480	37	< 500	< 50
ZTX 400 - 600A	200 - 480	40	< 500	< 50
ZTX 800 - 1200A	200 - 480	40	< 500	< 50

¹Under nominal conditions

²Time from source fail detection to contact closing on already-available secondary source

³All times consider that all timers are set to "0"

Table 7.3 Specified technical data of operating times

7.2 Circuit diagrams

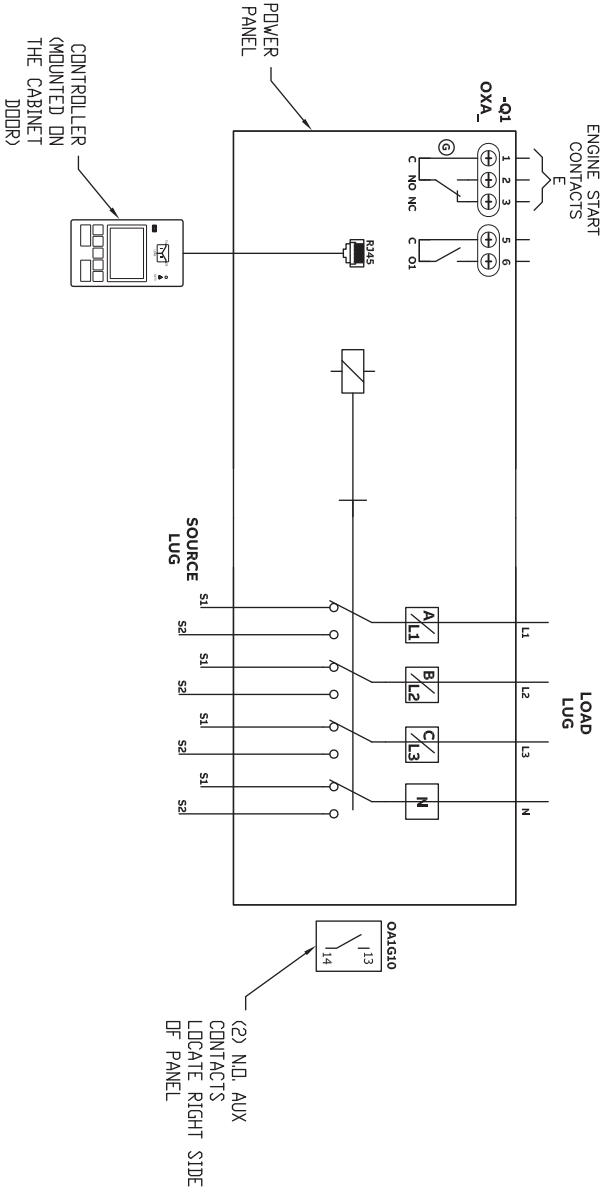

- NOTES:
1. ATS SHOWN IN SOURCE 1 POSITION WITH NO POWER AVAILABLE.
 2. REFER TO OPERATION AND MAINTENANCE MANUAL TO CONFIGURE THE OPTIONS.

Fig. 7.2 ZTX, open transition circuit diagram

7.3 Overall Dimensions

ZTX series dimensions and weights, UL Type 1 Enclosure

Model	ATS Rating (A)	Poles	Ref. Figure	Weight ¹ lb (kg)	Dimensions ² in (mm)		
					Height	Width	Depth
ZTX	30 - 200	2	A	89 (40)	32 (813)	24 (610)	12 (305)
		3	A	93 (42)	32 (813)	24 (610)	12 (305)
		4	A	98 (44)	32 (813)	24 (610)	12 (305)
	260	2	A	145 (66)	46 (1168)	24 (610)	14 (356)
		3	A	150 (68)	46 (1168)	24 (610)	14 (356)
		4	A	155 (70)	46 (1168)	24 (610)	14 (356)
	400	2	A	153 (69)	46 (1168)	24 (610)	14 (356)
		3	A	159 (72)	46 (1168)	24 (610)	14 (356)
		4	A	290 (131)	54 (1372)	28 (711)	19.5 (495)
	600	2	B	278 (126)	54 (1372)	28 (711)	19.5 (495)
		3	B	284 (129)	54 (1372)	28 (711)	19.5 (495)
		4	B	290 (131)	54 (1372)	28 (711)	19.5 (495)
800 - 1200	3	C	482 (219)	74 (1880)	40 (1016)	19.5 (495)	
	4	C	515 (234)	74 (1880)	40 (1016)	19.5 (495)	

¹Enclosures Type 3R weights are up to 22% greater than Type 1 Enclosures.

²Enclosures Type 3R dimensions differ. Consult Tech Support for details.

³All dimensions and weights are approximate and subject to change without notice.

⁴Packing materials must be added to weights shown. Allow 15% additional weight for cartons, skids, crates, etc.

1

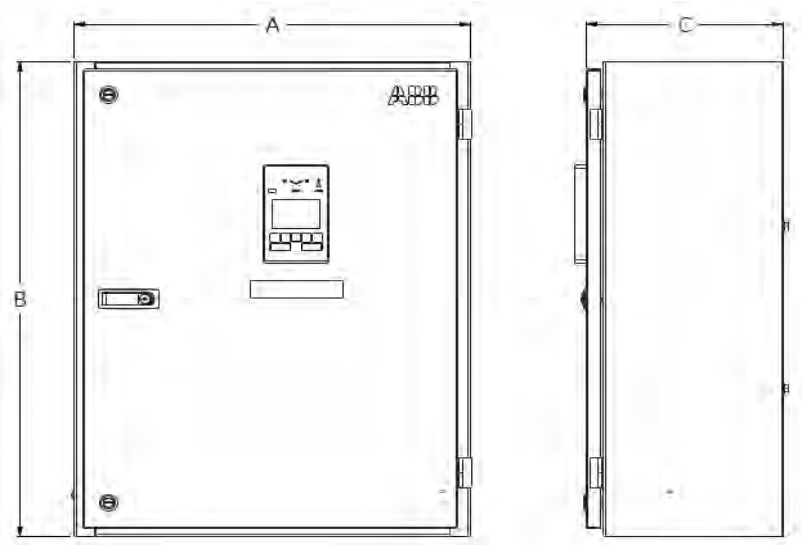

Figure A

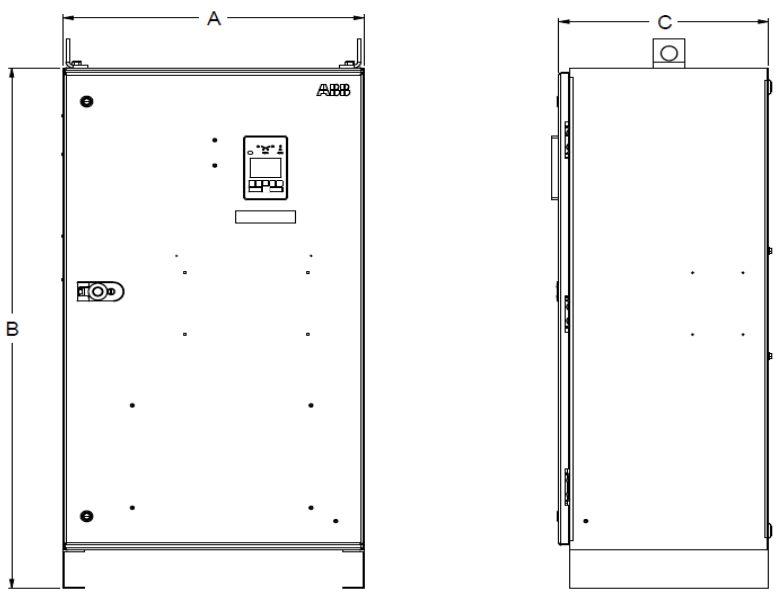

Figure B

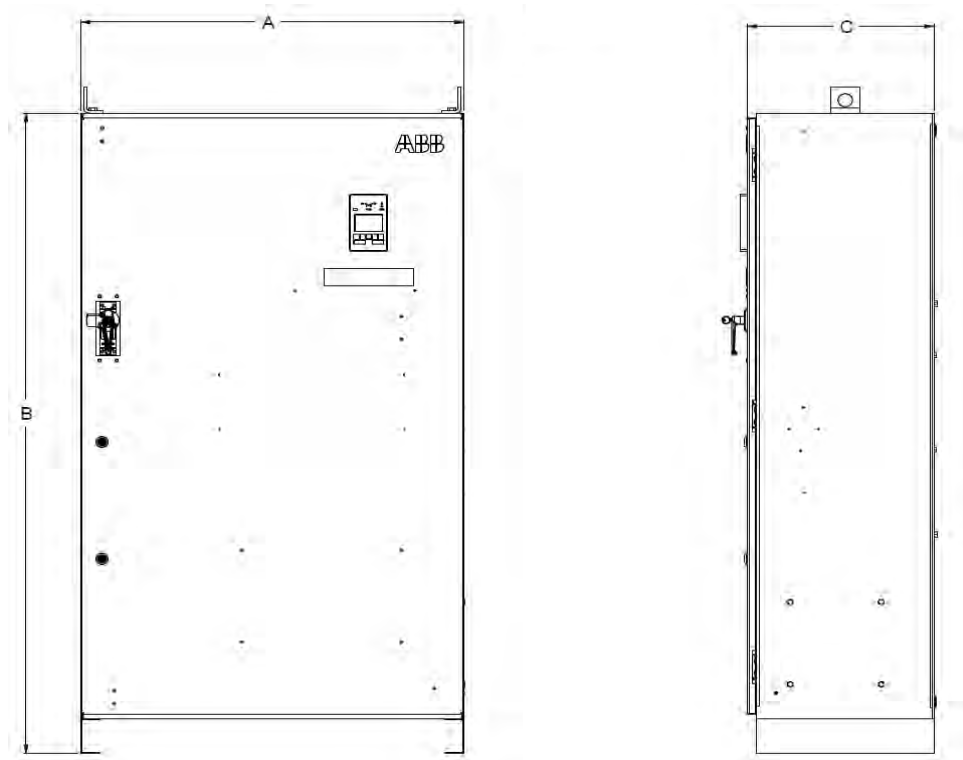

Figure C



8. Maintenance



Warning

Any maintenance should be conducted by trained and authorized personnel only. Appropriate personal protective equipment (PPE) shall be used when performing maintenance on the ATS panel. Hazardous voltage may be present. Disconnect all power sources before performing work inside the ATS panel. Failure to do so may result in serious injury or death.

Maintenance Principle

The Zenith ZTX series 30-1200 A, 200-480 Vac automatic transfer switches, powered by TruONE, are designed so that the contacts last their designed lifetime without any routine maintenance needs. If there are abnormal conditions such as a fault or overload without adequate protection, or extreme environment conditions, a failure of ATS components may occur. Fortunately, all critical modules, including controller, power module, HMI, and solenoid mechanism, as well as accessories are readily replaceable. Refer to section 11 for replacement parts.

On the other hand, when the contacts have seen a damaging fault event, or have met the end of their endurance lifetime, the whole switch should be replaced – which can be done easily by replacing the complete TruONE power panel within the enclosure.

In the case you suspect a failure may be due to manufacturer defect and covered under warranty, see section 1.3.

Refer to section 7 technical data for ATS contact endurance and note that the number of operations can be viewed using Ekip Connect software.

Routine Inspection

ABB recommends a routine (such as annual) inspection to, e.g. , check electrical termination temperatures, ensure unit is clean, check voltage levels, test transfers, # of operations, etc. to ensure everything is in proper working order.

Recommended annual inspection includes:

- Visual inspection both inside and outside of enclosure for damage or debris
- Test transfer of load
- Observe voltage levels of both sources within expected range
- Cable lug torque verification

Installation instruction

Automatic transfer switches

9. Panel installation	57
9.1 Basic Tools for Installation and Maintenance	58
9.2 Equipment Inspection and Storage	58
9.3 Lifting and mounting the panel	59
9.4 Mounting the automatic transfer switch	60
9.4.1 Mounting hole dimensions	60
9.5 Mounting of the handle	61
9.5.1 Mounting of the handle to operation position, manual mode	62
9.5.2 Mounting of the Handle, automatic mode	62
9.5.3 HMI Installation	63
9.6 Wire Connection	64
9.7 Final Equipment Inspection	64
9.8 Initial Energizing	65

10. Accessories	67
10.1 Phase barriers	67
10.2 Auxiliary contact blocks	68
10.3 HMI protective cover	69
11. Replacement parts	71

9. Panel installation

Before mounting the product, please, check the product identification from the product identification label, which is located on the front panel under the control interface unit (HMI). This label indicates the product model (type number), some important technical data information, suitable wire information, etc.



Notice

Final inspection of the equipment should be performed prior to energizing the automatic transfer.

Remove any dirt or debris that may have collected during shipment or installation. NEVER use compressed air. Doing so could drive dirt or other foreign objects into electrical or mechanical components, which could cause damage. Use an industrial-quality vacuum cleaner to remove any dirt or foreign objects.

Be certain all cable connections are correct and that the phase rotation of both sources match.

Inspect the engine start connections and verify the correct connection of all control wires.

Check all programmable set points and adjust as necessary. In addition, adjust any optional accessories as required.

Be certain that the actual lug torque values are in keeping with the requirements outlined in the instruction book to ensure the integrity of power connections.

Check to be sure that all covers and barriers are properly installed and fastened.

If any damage is found or suspected, file a claim as soon as possible with the carrier, and notify the nearest ABB Zenith representative, or call 1-800-637-1738.

9.1 Basic Tools for Installation and Maintenance

Tool	Task
1/4" to 1/2" Allen head socket driver	Power cable connection
Torque wrench	Torquing of the lugs and other hardware as required. Range of device to be 50 - 500 in-lbs (5-57 N-m)
Torque screwdriver	Torquing of control wire terminations, auxiliary contact input terminals. 5 - 25 in-lbs (0.5 - 2.8 N-m)
Wire cutters/wire crimpers	Auxiliary contacts wire installation, Options installation
Voltmeter	Trouble shooting tool for measuring incoming voltage, frequency, continuity and control signal transmission.

Table 9.1 Required tools for common installation and maintenance tasks

9.2 Equipment Inspection and Storage



Warning

When performing a hi-pot or dielectric test on the power section of the ATS panel, DISCONNECT the complete electronics, controller, and mechanism section of the ATS from the power section to avoid potential damage to the electronics.

Before installation, if it is necessary, store the transfer switch in a clean dry place, protected from dirt and water. Provide ample air circulation and heat, if necessary, to prevent condensation.

See table 7.1 for recommended storage and ambient operating temperatures.

Once you have received the transfer switch, inspect it for any damage. This includes damage to the enclosure, power panel, control panel and wiring harness. If any damage is found or suspected, file a claim as soon as possible with the carrier and notify the nearest ABB Zenith representative.

9.3 Lifting and Mounting the Panel

Lifting guidelines

Adequate lifting means must be used to mount the transfer switch into place. The recommended method for moving the ATS, up to 1200A, is with lifting strap and lifting equipment rated for the equipment weight.

Lifting, Mounting and Installation

The safe operation of your switch at all times is paramount to ABB. Please recognize that hazardous voltages and currents can exist during normal operation, and any maintenance on the transfer switch must be performed utilizing appropriate safety measures. Installation, adjustment, maintenance or removal of the switch must only be carried out by qualified personnel and with all power to the switch turned off. It is recommended that only qualified electricians be allowed to install or provide maintenance on the switch.

Prior to installation, store the transfer switch in a clean dry location, protected from dirt and water. Provide ample air circulation and heat if necessary to prevent condensation. See table 7.1 for recommended storage and ambient operating temperatures.

ABB Zenith automatic transfer switches are packaged as per the standard packaging regulatory standards requirement suitable for domestic and international shipment through all modes of transportation (air, sea and road). Once you unpack the units, please make sure all the components are received as per the BOM. For any missing items, contact your local ABB Zenith service representative.



Danger
Hazardous Voltage can Cause Severe Injury or Death

Turn OFF all power before installation, adjustment, or removal of transfer switch or any of its components.



Warning

Due to hazardous voltages and currents, ABB recommends that an ABB Certified technician or a qualified electrician perform the installation & maintenance of the switch.



Danger
Hazardous Voltage can Cause Severe Injury or Death

Automatic Transfer Switch Equipment must be electrically grounded. Failure to do so may result in malfunction of the switch and possible damage to surrounding equipment.



Warning

Before drilling conduit entry holes or any accessory mounting holes, cover and protect the switch and control panel to prevent dirt and metal fragments from entering the mechanical and electrical components.

9.4 Mounting the automatic transfer switch

9.4.1 Mounting hole dimensions

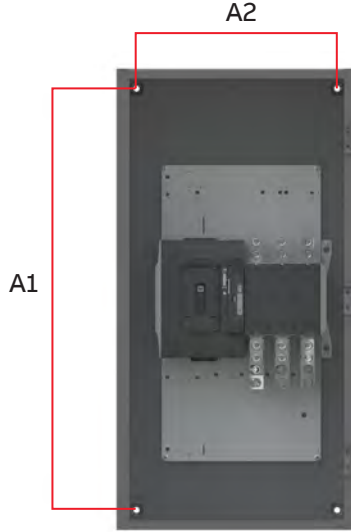

Fig. 9.1 Automatic transfer switches, Mounting hole dimensions, refer to Table 9.2 for A1 and A2 values

ZTX series enclosure mounting dimensions

Model	ATS Rating (A)	Poles	Type 1, in (mm)		Type 3R/4/4X/12, in (mm)	
			Height (A1)	Width (A2)	Height (A1)	Width (A2)
ZTX	30 - 200	2	28.0 (711)	20.0 (508)	33.3 (845)	18.0 (457)
		3	28.0 (711)	20.0 (508)	33.3 (845)	18.0 (457)
		4	28.0 (711)	20.0 (508)	33.3 (845)	18.0 (457)
	260	2	42.0 (1067)	20.0 (508)	47.25 (1200) ¹	18.0 (457)
		3	42.0 (1067)	20.0 (508)	47.25 (1200) ¹	18.0 (457)
		4	42.0 (1067)	20.0 (508)	47.25 (1200) ¹	18.0 (457)
	400	2	42.0 (1067)	20.0 (508)	47.25 (1200) ¹	18.0 (457)
		3	42.0 (1067)	20.0 (508)	47.25 (1200)	18.0 (457)
		4	46.0 (1168)	24.0 (610)	51.25 (1302)	22.0 (559)
	600	2	46.0 (1168)	24.0 (610)	51.25 (1302)	22.0 (559)
		3	46.0 (1168)	24.0 (610)	51.25 (1302) ¹	22.0 (559)
		4	46.0 (1168)	24.0 (610)	51.25 (1302) ¹	22.0 (559)
800 - 1200	3	66.0 (1676)	35.0 (889)	71.3 (1810) ¹	34.0 (864)	
	4	66.0 (1676)	35.0 (889)	71.3 (1810) ¹	34.0 (864)	

1) 4X enclosures add 0.05 inches to dimension.

Table 9.2 Zenith ZTX panel mounting dimensions

9.5 Mounting of the handle

For more information of operating, position indication and the selection of the operating mode, see the Chapter 3.2 Operating and locking.

More information, see animation: Manual and automatic operation - TruONE® ATS (<https://youtu.be/bosvSPVi2sM>).



Warning

Verify the condition of power source prior to manually transferring. Manual operation may result in out-of-phase transfer when both sources are energized.

9.5.1 Mounting of the handle to operation position, manual mode

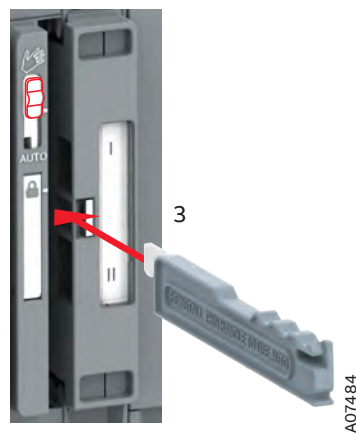
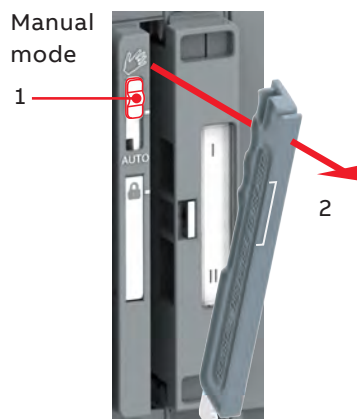

A07484

Fig. 9.2 Mounting the handle to the operating position; turn the side switch to the Manual mode (Hand), lift the handle and place it to the operating position

9.5.2 Mounting of the Handle, automatic mode

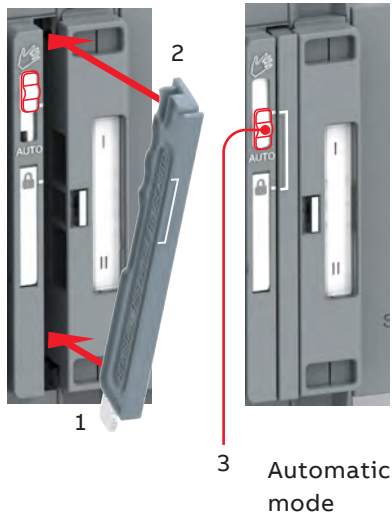
**Notice**

When the slide switch is moved to the AUTO position, the ATS is functioning immediately in the automatic control mode.

Fig. 9.3 Before moving to the Automatic mode, the operating handle must set to its place. When the handle is in its place properly, the slide switch will move to the Locking mode automatically and the switch is allowed to be padlocked, if needed. From the Locking mode the slide switch can be moved to the Automatic mode

9.5.3 HMI Installation



Max. 3 m,
HMI (RJ45) cable

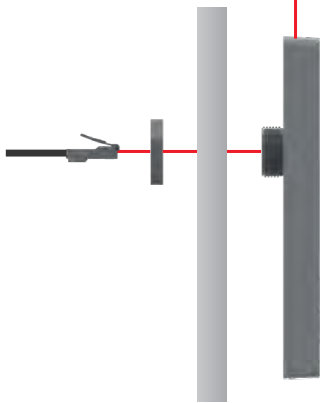

A07490

Fig. 9.4 HMI can be mounted on the switch or the door, door drilling. HMI protective cover available as accessory, type OXEC21, provides protection against accidental contact, see Chapter 10.3., Mounting of accessories

9.6 Wire Connection



Notice
Lugs come pre-installed and torqued

ZTX series AL/CU UL Listed Solderless Screw-Type Terminals for External Power Connections

Model	ATS Rating (A)	Source/Load	Lug Type	Wire Range	Cables per pole	Cables - Tightening Torque ¹ , lb-in (N-m)
ZTX	30 - 60	Source 1	OZXA-24	14 - 2/0 AWG	1	50/5.7
		Source 2 / Load	OZXA-100	12 - 2/0 AWG	1	132/15.0
	100 - 200	Source 1	OZXA-25	6 AWG - 300 KCMIL	1	275 / 31.1
		Source 2 / Load	OZXA-200	4 AWG - 300 KCMIL	1	200 / 22.6
	260 - 400	Source 1	OZXA-26	2 AWG - 600 KCMIL	1	375 / 42.4
		Source 2 / Load	OZXA-400	2 AWG - 600 KCMIL	1	375 / 42.4
	600	Source 1	OZXA-800L	2 AWG - 600 KCMIL	2	500/56.5
		Source 2 / Load	OZXA-800E	2 AWG - 600 KCMIL	2	500/56.5
	800 - 1200	Source 1	OZXA-1200	2 AWG - 600 KCMIL	4	500/56.5
		Source 2 Load	OZXA-800S OZXA-1200	2 AWG - 600 KCMIL 2 AWG - 600 KCMIL	4 4	500/56.5 500/56.5

¹Do not exceed this value - may cause damage to switch, voiding warranty

Table 9.3 Power Cable Torque Requirements

9.7 Final Equipment Inspection

Prior to energizing the transfer switch:

1. Remove any debris incurred, with a vacuum, due to shipment or installation.
2. Verify that all cabled connections are correct and that phase rotation of both sources match.
3. Check engine start connections.
4. Verify the correct connection of all control wires.
5. Check settings of all timers and adjust as necessary.
6. Adjust any optional accessories as required.
7. Check the lug torque values of the power connections.
8. Make sure that all covers and barriers are installed and properly fastened.

For simple details on start-up refer to ZTX Quick start guide document number 1SCC303022K0201.

Each ABB Zenith transfer switch is factory wired and tested. A complete information package is furnished with each switch which includes:

- Sequence of operation.
- Description and operation of all accessories supplied.
- Power panel connection diagram and schematic.
- Description and identification of all customer field connections.

Installation of ABB Zenith transfer switches includes:

- Mounting the transfer switch cabinet.
- Connection of Source 1, Source 2, and Load cables or bus bars.
- Connection of external control circuits as required.

9.8 Initial Energizing

Before proceeding, refer to the information package supplied with the ATS and read and understand the information on all accessories provided, including this complete document.

Before energizing the panel

1. Confirm that installation has been performed by a qualified person and in accordance with NFPA 70 (NEC).



Notice

Ensure this installation is properly operated and maintained in accordance with the safety practices of NFPA 70E.

2. Confirm rating label matches the installed application. Rating label is located inside the panel enclosure.
3. Confirm that cables are connected properly and torqued according to label the ATS labeling.
4. Verify that the enclosure ground connection is properly terminated.
5. Confirm that control wiring for engine start is properly terminated to the engine start contact (located in Figure 2.1, number 8). Additionally, connect all applicable digital I/O and auxiliary contact wiring.
6. Flip slide switch (Figure 2.1, number 4) to AUTO.
7. Ensure that all objects and debris are removed from enclosure, and enclosure is closed and latched.

Energizing the panel

1. Close Source 1 circuit breaker.

NOTE: The HMI should illuminate if line voltage is present and S1 LED should light up.

2. Verify the phase to phase voltages at the Source 1 terminals.
3. Initiate auto configure from HMI DIP-switch and allow a few seconds for system parameters to set before returning the switch to off.
4. Close the Source 2 circuit breaker.
5. Start the generator engine.

NOTE: If generator voltage is present at Source 2 terminals, S2 LED should light up.

6. Verify phase rotation of S1 matches that of S2.

NOTE: The ATS will not allow transfer if phase rotation does not match.

7. Shut down the generator engine.
8. Place the ATS in AUTO mode from the HMI by pressing AUTO key.
9. For additional start-up guidance for the ATS, please refer to ZTX Quick Start Guide, document number 1SCC303022K0201.

10. Accessories



Warning

Any installation or maintaining of accessories should be conducted by trained and authorized personnel only.

Appropriate personal protective equipment (PPE) shall be used when troubleshooting the ATS panel.

Hazardous voltage may be present. Disconnect all power sources before performing work inside the ATS panel.

Failure to do so may result in serious injury or death.

More information, see animation: Installation of accessories - TruONE® ATS (<https://youtu.be/qV2KolV38GY>).



10.1 Phase barriers

Phase barriers must be used to maintain a clearance of 1 inch on the automatic transfer switch types. They are included with the shipment of ZTX series ATS Panel.

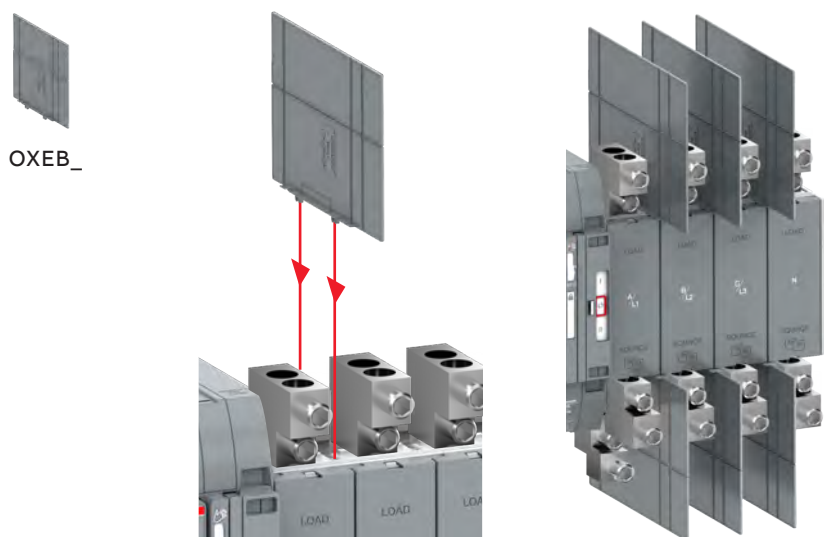

Fig. 10.1 Mounting of phase barriers, type OXEB_

10.2 Auxiliary contact blocks

Position	OA1G10	OA3G01
SOURCE 1 (S1), max 2+2		
I		
O		
II		
SOURCE 2 (S2), max 2+2		
I		
O		
II		

Table 10.1 Contact positions

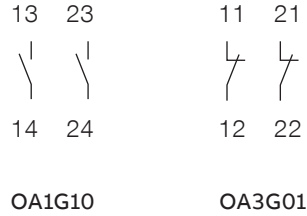

Fig. 10.3 Labels for contact numbering

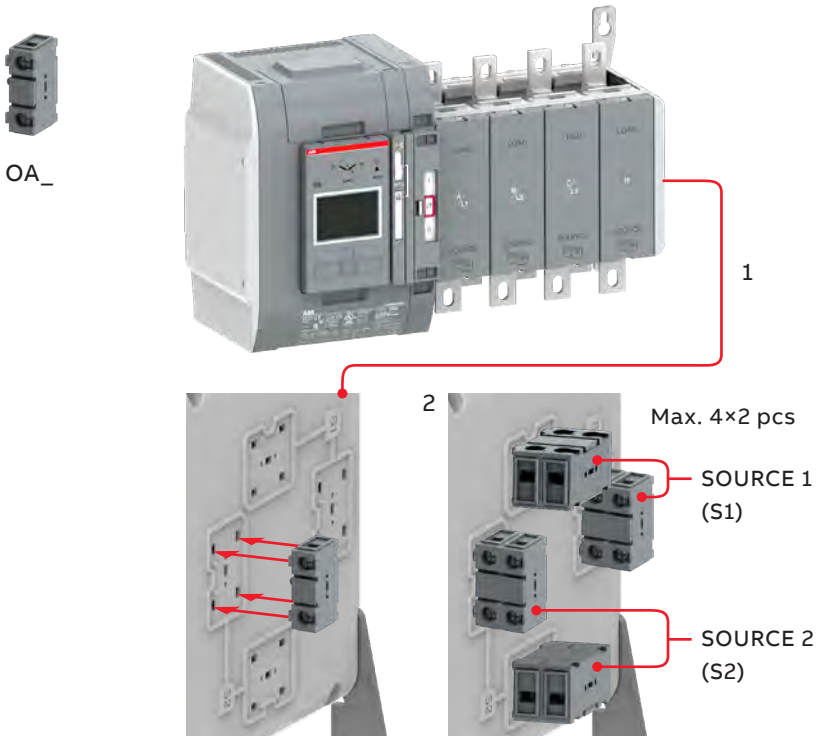
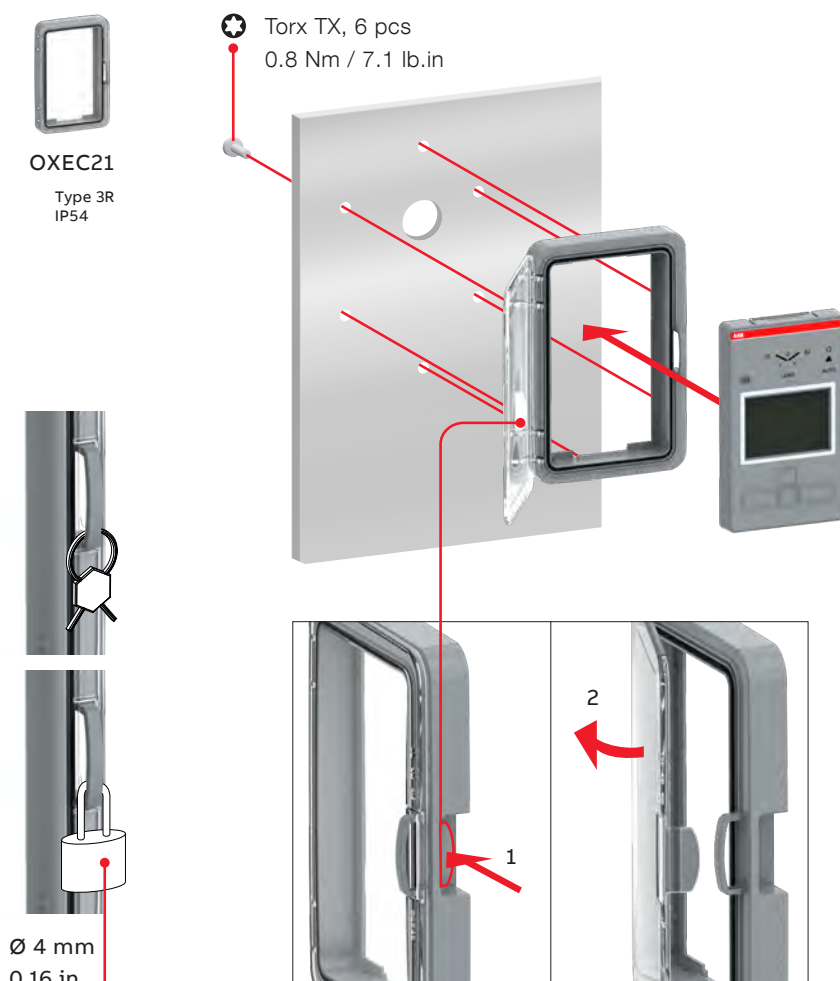

Fig. 10.2 Mounting of the auxiliary contact blocks, type OA_

10.3 HMI protective cover

UL Type 3R HMI protective cover, type OXEC21, provides protection against water ingress. It comes standard with NEMA 3R enclosures, and is available as a replacement part.

Fig. 10.4 Mounting of HMI protective cover, type OXEC21



11. Replacement Parts

ZTX series replacement parts			
Type	Suitable for Switches	Order code	Weight (lb)
HMI module	Open transition (ZTX 30-1200 A, 200-480 Vac)	OXAHMI-L2	0.42
Manual handle	Open transition and delayed transition (ZTX 30-1200 A, 200-480 Vac)	OXHANDLE-1600	0.18
	Open transition (ZTX, 200-480 Vac)		
Complete ¹ mechanism with electronics	30-260 Amps	OXAMECH-2-L2	16.28
	400-600 Amps	OXAMECH-3-L2	21.12
	800-1200 Amps	OXAMECH-4-L2	23.32
Phase barrier	30-1200 Amps, 3 pole	OXEB1600/4	1.10
	30-1200 Amps, 4 pole	OXEB1600/6	1.54

¹Includes the tested, field replaceable module complete with operating mechanism, power module, and controller

Fig. 11.1 Replacement parts, available in Empower



Contact us

ABB Zenith Controls, Inc.

305 Gregson Drive
Cary, NC 27511

24-hour support:

ABB Technical Services
+1 (800) 637-1738
epis.pqs-service@abb.com

abb.com/lowvoltage