

FOR INDIVIDUAL GEN SET MODEL TYPES & ENGINE DATA SHEETS SEE [WWW.BROADCROWN.COM](http://WWW.BROADCROWN.COM)  
 ENGINE TYPE : VOLVO TAD 1350 SERIES - 1800 TIER 3  
 GENERATOR IS TO BE PLACED ON A FLAT FLOOR OF CONCRETE BASE

GEN SET MODEL	ENGINE	ALTERNATOR	WEIGHT (DRY)	WEIGHT (WET)
BCV 250 - 60	TAD 1350 GE	HCI 444 C	4490 Kg's	5430 Kg's
BCV 300 - 60	TAD 1351 GE	HCI 444 D	4580 Kg's	5520 Kg's
BCV 350 - 60	TAD 1352 GE	HCI 444 E	4665 Kg's	5605 Kg's
BCV 400 - 60	TAD 1353 GE	HCI 444 F	4800 Kg's	5740 Kg's

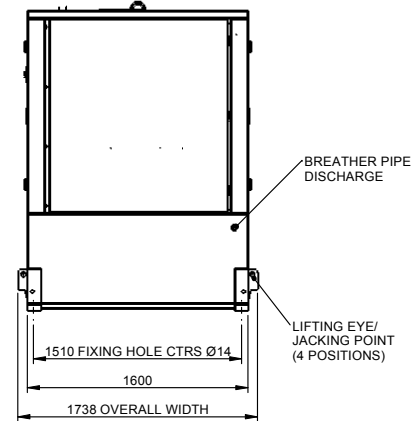
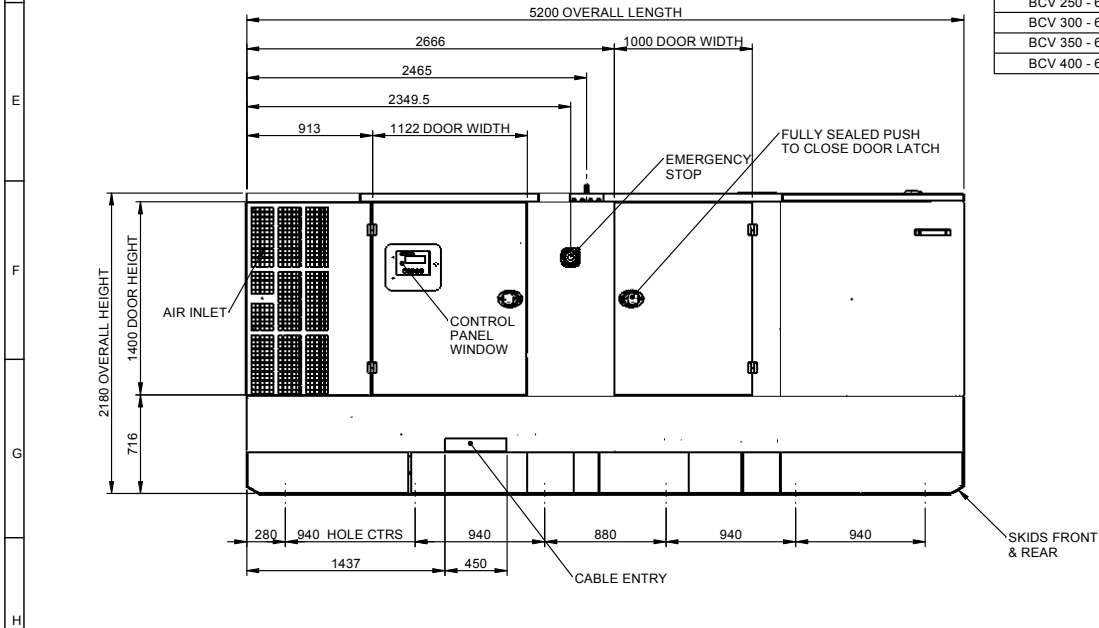

MATERIAL:	
FINISH:	

B	GENERATOR WEIGHTS ADDED.	11/11/09 P.R
C	FRONT AND REAR ACCESS DOOR DETAIL ADDED.	16/06/10 P.R
D	Drawing Template Updated	21/06/10 SJB

REV	DETAILS	APP'D	DATE

NOTES - MECHANICAL  
 TOLERANCES:  
 GENERAL TOLERANCES: +/- 5mm  
 FABRICATION: +/- 3mm  
 HOLE CENTRES: +/- 1mm  
 OTHER TOLERANCES AS OTHERWISE STATED WHERE REQUIRED  
 GEOMETRICAL AND OTHER TOLERANCES AS STATED.  

 THIRD ANGLE PROJECTION

DESCRIPTION	
C5R TAD1350 Series Sales GA	
SHEET 1 of 1	
CREATED BY:	P RUTTER
DATE:	29/09/09
MODIFIED BY:	S BEAN
DATE:	21/06/10
CHECKED BY:	P RUTTER
DATE:	21/06/10
ISSUE:	D

DRAWING No:  
**VGA013**  
  
 Broadcrown Limited (Group Headquarters)  
 Airfield Industrial Estate, Hixon, Stafford,  
 ST18 0PF, United Kingdom.  
 tel: +44 (0) 1889 272200  
[www.broadcrown.com](http://www.broadcrown.com)