

STAMFORD[®]

MX342 Automatic Voltage Regulator (AVR) Specification Installation and Adjustments

General description

The MX342 is a two phase sensed Automatic Voltage Regulator (AVR) and forms part of the excitation system for a STAMFORD brushless ac generator.

This AVR features a linear volts / Hz slope down to 18Hz, and current limiting (when fitted with an additional CT).

Excitation power is derived from a three-phase permanent magnet generator (PMG), to isolate the AVR control circuits from the effects of non-linear loads and to reduce radio frequency interference on the generator terminals. Sustained generator short circuit current is another feature of the PMG system.

The AVR senses the voltage in the main generator winding and controls the power fed to the exciter stator and hence the main rotor to maintain the generator output voltage within the specified limits, compensating for load, speed, temperature and power factor of the generator.

A frequency measuring circuit continually monitors the shaft speed of the generator and provides under-speed protection of the excitation system by reducing the generator output voltage linearly with speed below a pre-settable threshold.

Soft start circuitry is included to provide a smooth controlled build up of generator output voltage.

Uncontrolled excitation is limited to a safe period by internal shutdown of the AVR output device. This condition remains latched until the generator has stopped.

Provision is made for the connection of a remote voltage trimmer, allowing the user fine control of the generator's output.

An analogue input is provided allowing connection to a STAMFORD Power Factor controller or other external devices with compatible output.

The AVR has the facility for droop CT connection, to allow parallel running with other similarly equipped generators.

An additional CT input is provided for stator current limiting.

STAMFORD-AVK part number: E000-23422

Technical specification

SENSING INPUT AT RATED SPEED

Voltage 190-264 Vac max, 1 phase, 2 wire
Frequency 50-60 Hz

POWER INPUT (PMG) AT RATED SPEED

Voltage 170-220 Vac max, 3 phase, 3 wire
Current 3A/phase
Frequency 100-120 Hz

OUTPUT

Voltage max 120V dc
Current continuous 2.7 A
Intermittent 6A for 10 secs.
Resistance 15 ohms minimum

REGULATION

+/- 1% average sensing (see note 1)

THERMAL DRIFT

0.03% per deg. C change in AVR ambient (note 2)

SOFT START RAMP TIME

3 seconds

TYPICAL SYSTEM RESPONSE

AVR Response 10ms
Filed current to 90% 80 ms
Machine Volts to 97% 300ms

EXTERNAL VOLTAGE ADJUSTMENT

+/-10% with 1 k ohm 1 watt trimmer (see note 3)

UNDER FREQUENCY PROTECTION

Set point 59.5 Hz (see note 4)
Slope linear down to 18 Hz

UNIT POWER DISSIPATION

12 watts maximum

ANALOGUE INPUT

Maximum input +/- 5 Vdc (see note 5)
Sensitivity 1v for 5% Generator Volts (adjustable)
Input resistance 1k ohm

QUADRATURE DROOP INPUT

10 ohms burden
Max. sensitivity: 0.07 A for 5% droop OPF
Max. input: 0.33 A

CURRENT LIMIT INPUT

27 ohms burden
Max. sensitivity: 0.28 A (see note 6)
Max. input: 0.33 A

OVER EXCITATION PROTECTION

Set point 75 V dc
Time delay 10 seconds (fixed)

ENVIRONMENTAL

Vibration 20-100 Hz 50mm/sec
100Hz - 2kHz 3.3g
Operating temperature -40 to +70°C
Relative Humidity 0-70°C 95% (see note 7)
Storage temperature -55 to +80°C

NOTES

1. With 4% engine governing.
2. After 10 minutes.
3. Generator de-rate may apply. Check with factory.
4. User adjustable.
5. Any device connected to the analogue input must be fully floating (galvanically isolated from ground), with an insulation strength of 500V ac.
6. The CT phase position should be the same as the droop CT.
7. Non condensing.

Design Detail

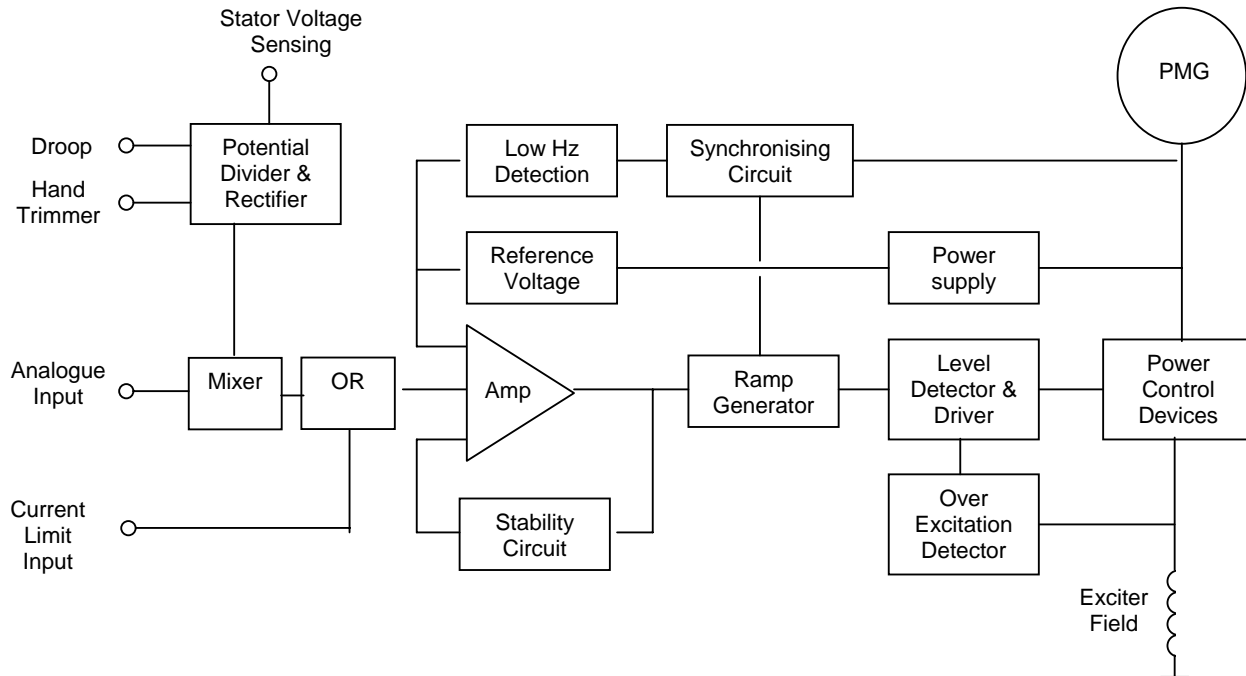

The main functions of the AVR are:

The Potential Divider and Rectifier takes a proportion of the generator output voltage and attenuates it. The potential divider is adjustable by the AVR Volts potentiometer and external hand trimmer (when fitted). The output from the droop CT is also added to this signal. An isolating transformer is included allowing connection to various winding configurations. A rectifier converts the a.c. input signal into d.c. for further processing.

The Mixer adds the Analogue input signal to the Sensing signal.

The Current Limit input and the output from the Stator Voltage Sensing circuit are applied to the OR circuit. This determines which sensed input should be used for control. The highest input takes priority.

The Amplifier (Amp) compares the sensing voltage to the Reference Voltage and amplifies the difference (error) to provide a controlling signal for the power devices. The Ramp Generator and Level Detector and Driver infinitely control the conduction period of the Power Control Devices, and hence provide the excitation system with the required power to maintain the generator voltage within specified limits.

The Stability Circuit provides adjustable negative ac feedback to ensure good steady state and transient performance of the control system.

The Low Hz Detector measures the period of each electrical cycle and causes the reference voltage to be reduced approximately linearly with speed below a pre-settable threshold. A Light Emitting Diode gives indication of under-speed running.

A further enhancement of this feature is the variable DIP adjustment, which provides greater voltage roll off to aid the recovery of turbo charge engines taking large impact loads.

The Synchronising circuit is used to keep the Ramp Generator and Low Hz Detector locked to the Permanent Magnet Generator waveform period.

Power Control Devices vary the amount of exciter field current in response to the error signal produced by the Amplifier.

The Over Excitation Detector continuously monitors the exciter field voltage and provides signals to shut down the power device if an over excitation condition persists for the specified time period.

The Power Supply provides the required voltages for the AVR circuitry.

Fitting and Operating

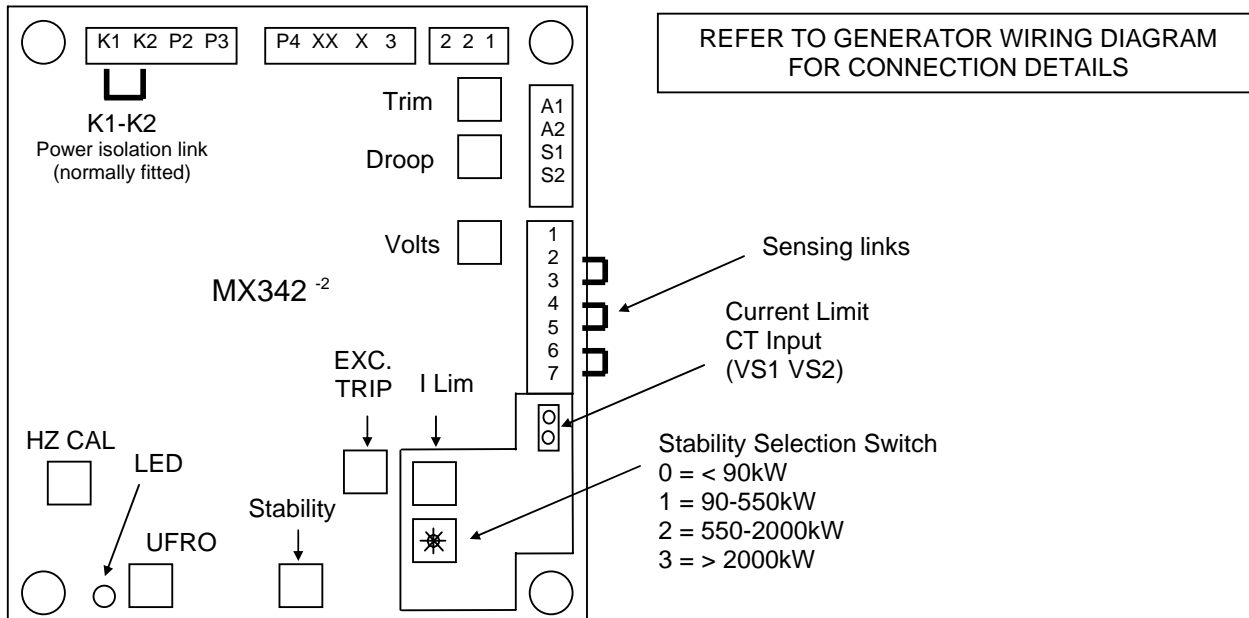

SUMMARY OF AVR CONTROLS

CONTROL	FUNCTION	DIRECTION
VOLTS	TO ADJUST GENERATOR OUTPUT VOLTAGE	CLOCKWISE INCREASES OUTPUT VOLTAGE
STABILITY	TO PREVENT VOLTAGE HUNTING	CLOCKWISE INCREASE THE DAMPING EFFECT
UFRO	TO SET THE UFRO KNEE POINT	CLOCKWISE REDUCES THE KNEE POINT FREQUENCY
DROOP	TO SET THE GENERATOR DROOP TO 5% AT 0PF	CLOCKWISE INCREASES THE DROOP
VTRIM	TO OPTIMISE ANALOGUE INPUT SENSITIVITY	CLOCKWISE INCREASES THE GAIN OR SENSITIVITY
EXC TRIP	TO SET THE OVER EXCITATION CUT OFF LEVEL	CLOCKWISE INCREASE THE CUT OFF LEVEL
I LIM	TO SET THE GENERATOR CURRENT LIMIT	CLOCKWISE INCREASES THE CURRENT
HZ CAL	TO CALIBRATE THE UFRO CIRCUIT	NOT FOR USER ADJUSTMENT

ADJUSTMENT OF AVR CONTROLS

VOLTAGE ADJUSTMENT

The generator output voltage is set at the factory, but can be altered by careful adjustment of the VOLTS control on the AVR board, or by the external hand trimmer if fitted. Terminals 1 and 2 on the AVR should be fitted with a shorting link if no hand trimmer is required.

WARNING! Do not increase the voltage above the rated generator voltage. If in doubt, refer to the rating plate mounted on the generator case.

WARNING! Do not ground any of the hand trimmer terminals, as these could be above earth potential. Failure to observe this could cause equipment damage.

If a replacement AVR has been fitted or re-setting of the VOLTS adjustment is required, proceed as follows:

WARNING!

1. Before running generator, turn the VOLTS control fully anti-clockwise.
2. Turn remote volts trimmer (if fitted) to midway position.
3. Turn STABILITY control to midway position.
4. Connect a suitable voltmeter (0-300V ac) across line to neutral of the generator.
5. Start generator set, and run on no load at nominal frequency e.g. 50-53Hz or 60-63Hz.
6. If the red Light Emitting Diode (LED) is illuminated, refer to the Under Frequency Roll Off (UFRO) adjustment.
7. Carefully turn VOLTS control clockwise until rated voltage is reached.
8. If instability is present at rated voltage, refer to stability adjustment, then re-adjust voltage if necessary.
9. Voltage adjustment is now completed.

STABILITY ADJUSTMENT

The AVR includes a stability or damping circuit to provide good steady state and transient performance of the generator.

The correct setting can be found by running the generator at no load and slowly turning the stability control anti-clockwise until the generator voltage starts to become unstable.

The optimum or critically damped position is slightly clockwise from this point (i.e. where the machine volts are stable but close to the unstable region).

OPTIMUM RESPONSE SELECTION

The stability selection switch should be correctly adjusted, according to the frame size of the generator, (see drawing on previous page).

UNDER FREQUENCY ROLL OFF (UFRO) ADJUSTMENT

The AVR incorporates an under-speed protection circuit which gives a linear volts / Hz characteristic when the generator speed falls below a pre-settable threshold known as the "knee" point.

The red Light Emitting Diode (LED) gives indication that the UFRO circuit is operating.

The 'knee point' adjustment on this AVR should be set by the user to give the required characteristics. Over excitation conditions must be avoided.

For optimum setting, the LED should illuminate as the frequency falls just below nominal, i.e. 47-49Hz on a 50Hz system or 57-59Hz on a 60Hz system. Please consult the factory for special requirements.

DROOP ADJUSTMENT

Generators intended for parallel operation are fitted with a quadrature droop C.T. which provides a power factor dependent signal for the AVR. The C.T. is connected to S1, S2 on the AVR.

When the AVR is supplied fitted to a generator, the DROOP adjustment is normally preset in the works to give 5% voltage droop at full load zero power factor. AVR's supplied loose will require adjustment.

Clockwise increases the amount of C.T. signal injected into the AVR and increases the droop with lagging power factor ($\cos \phi$). With the control fully anti-clockwise there is no droop.

TRIM ADJUSTMENT

An analogue input (A1 A2) is provided to connect to the STAMFORD Power Factor Controller or other devices. It is designed to accept dc signals up to +/- 5 volts.

WARNING! Any devices connected to this input must be fully floating and galvanically isolated from ground, with an insulation capability of 500 Vac. Failure to observe this could result in equipment damage.

The dc signal applied to this input adds to the AVR sensing circuit. A1 is connected to the AVR 0 volts. Positive on A2 increases excitation. Negative on A2 decreases excitation.

The TRIM control allows the user to adjust the sensitivity of the input. With TRIM fully anti-clockwise the externally applied signal has no effect. Clockwise it has maximum effect.

Normal setting is fully clockwise when used with a STAMFORD Power Factor Controller.

OVER EXCITATION (EXC TRIP) ADJUSTMENT

The adjustment is set and sealed in the works and should not be altered.

An over excitation condition is indicated on the common LED which also indicates under speed running.

The generator must be stopped to reset an over excitation condition.

I LIMIT ADJUSTMENT

The AVR incorporates a generator stator current limit feature. This is commonly used to assist engine recovery when starting very large motors. To use this feature, a suitable C.T. should be fitted to the generator output leads. The secondary terminals of the C.T. should be connected to VS1, VS2 on the AVR auxiliary board. Clockwise adjustment of the ILIM potentiometer increases the current level.

HZ CAL ADJUSTMENT

The adjustment is set and sealed in the works and should not be altered.

STAMFORD®

Barnack Road • Stamford • Lincolnshire • PE9 2NB
Tel: 00 44 (0)1780 484000 • Fax: 00 44 (0)1780 484100