

OUTLINE FOR ASCO® 300 SERIES 800-1000 AMPERE "H" FRAME (H3ATS,H3NTS,H3ADTS,H3NDTS) FRONT CONNECTED TRANSFER SWITCHES TYPE 1 ENCLOSURE

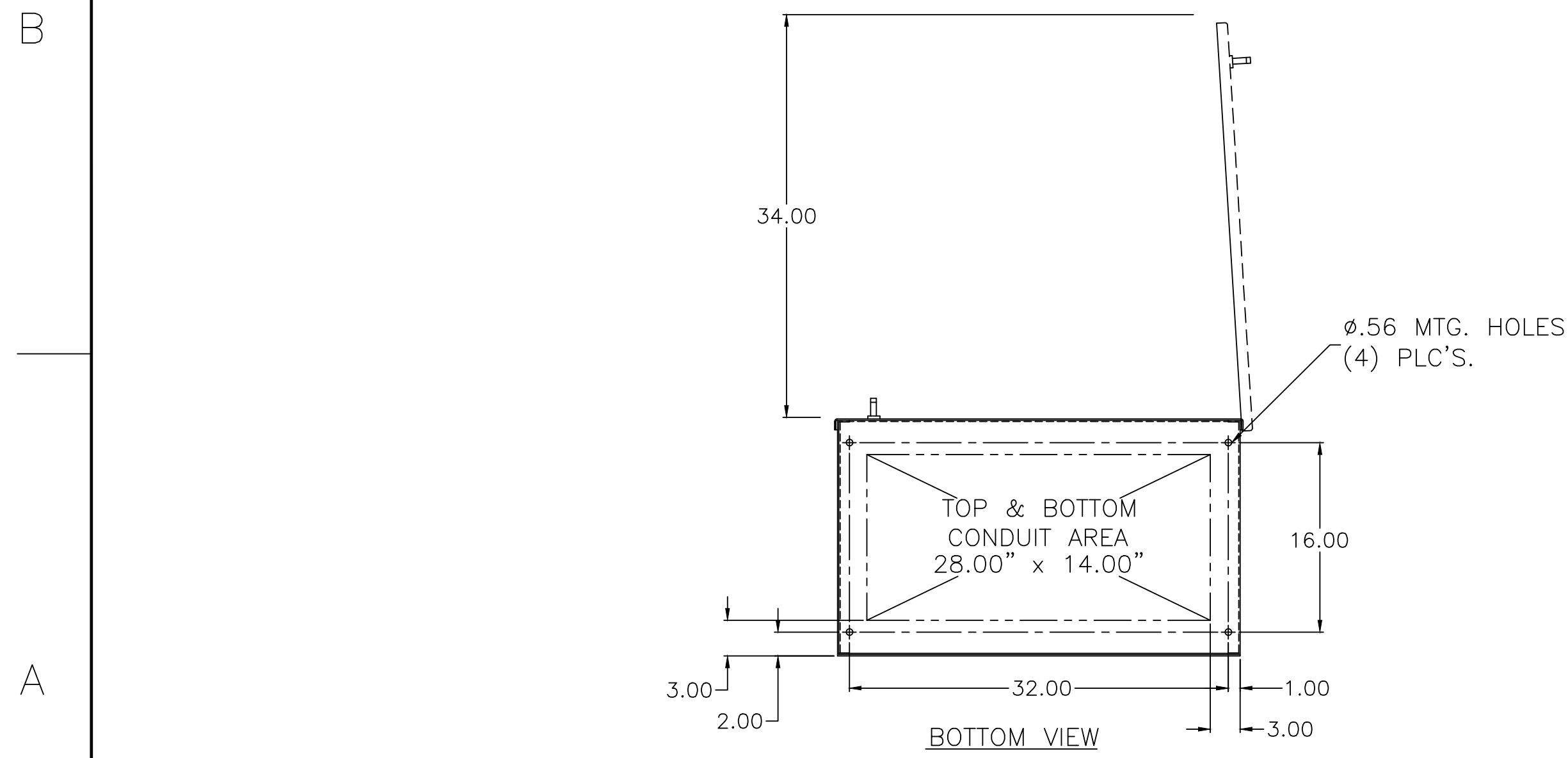
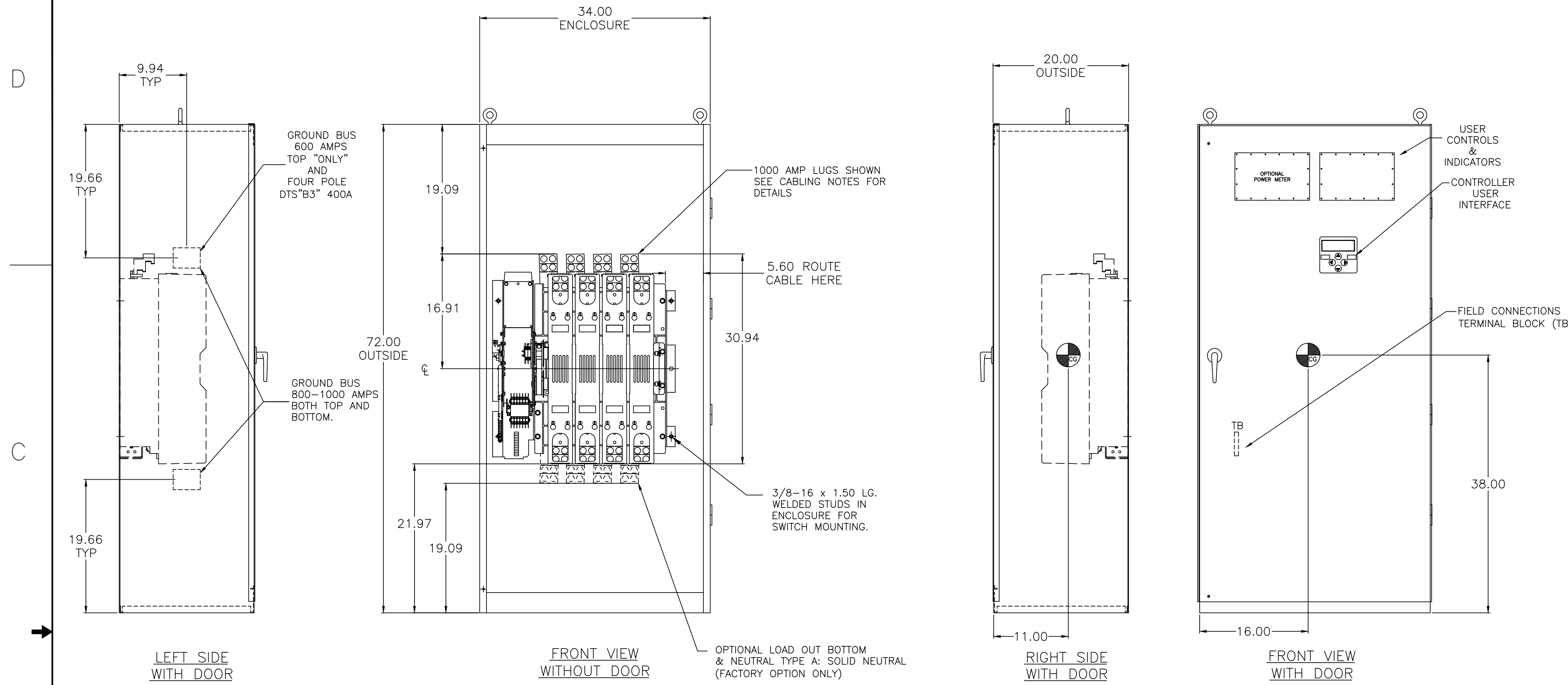

- ### GENERAL NOTES
- TYPE 1 ENCLOSURE. FREE STANDING. FLOOR MOUNTED. CODE GAUGE FORMED FRAME CONSTRUCTION.
 - NEC STANDARD GAUGE PAN TYPE DOOR WITH LOCKABLE HANDLE.
 - FINISH: ANSI 61 GRAY, POLYESTER POWDER STANDARD. OTHER ANSI COLORS AVAILABLE CONSULT FACTORY UL RECOGNIZED.
 - RECOMMENDED CLEARANCES: FRONT: 36 INCHES
 - A 20% RATED GROUND BUS IS PROVIDED.
 - UNIT IS DESIGNED FOR COMBINATION TOP AND BOTTOM CABLE ENTRY. THE STANDARD SWITCH CONFIGURATION IS FOR TOP LUGS EMERGENCY AND LOAD AND BOTTOM LUGS NORMAL. OPTIONALLY, THE SWITCH MAY BE SUPPLIED WITH REVERSE NORMAL & EMERGENCY LUGS. (REFER TO THE WIRING DIAGRAM FURNISHED WITH EACH TRANSFER SWITCH TO DETERMINE TERMINATION POSITIONS).
 - NEUTRAL CONFIGURATIONS:
 AN OPTIONAL FULL RATED NEUTRAL CONFIGURATION FOR EACH SOURCE AND THE LOAD MAY BE PROVIDED. WHEN EQUIPPED IT IS IN ONE OF THE FOLLOWING FORMATS AS SPECIFIED BY THE CATALOG NUMBER NO. NEUTRAL TYPE:
 (A) SOLID (COPPER BUS) NEUTRAL
 (B) SWITCHED NEUTRAL POLE
 - CENTER OF GRAVITY
 - NO KNOCKOUTS ARE PROVIDED.

- ### CABLING NOTES
- ALL SIZES SUPPLIED STANDARD WITH MECHANICAL (SCREW TYPE) LUGS. (SEE AMP SIZE BELOW)
 A. LUG MATERIAL: ALUMINUM ALLOY 6061-T6 WITH ELECTRO TIN PLATED FINISH.
 B. SCREW MATERIAL: ALUMINUM ALLOY 6262-T9 WITH ELECTRO TIN PLATED FINISH.
 C. UL LISTED, CSA CERTIFIED.
 D. LUG SCREW TIGHTENING TORQUE PER UL 486B: 19 FT-LBS.
 E. SUITABLE WIRE BENDING SPACE IS PROVIDED. (SEE AMP SIZE BELOW)
 - OPTIONAL COPPER CRIMP LUGS MAY BE SUPPLIED. (SEE AMP SIZE BELOW)
 A. LUG MATERIAL: HIGH CONDUCTIVITY WROUGHT COPPER FINISH, ELECTRO TIN PLATED.
 B. UL LISTED, CSA CERTIFIED.
 C. LUG MOUNTING HARDWARE TIGHTENING TORQUE: (REFER TO WITHSTAND CURRENT RATING LABEL PROVIDED ON EACH TRANSFER SWITCH).
 D. SUITABLE WIRE BENDING SPACE IS PROVIDED. (SEE AMP SIZE BELOW)
 - CONSULT FACTORY FOR OTHER TERMINATION REQUIREMENTS.
 - GROUND LUGS ARE PROVIDED STANDARD AS FOLLOWS. (SEE AMP SIZE BELOW).

- ### NOTES 600 AMP SWITCHES
- SUPPLIED WITH STANDARD MECHANICAL (SCREW TYPE) LUGS ON THE NORMAL, EMERGENCY & LOAD BUS STABS. ONE (1) LUG PER PHASE AND NEUTRAL EACH SUITABLE FOR CONNECTION OF TWO (2) #2 -600MCM CU/AL CABLE (SEE NOTE "E" BELOW).
 A. SUITABLE WIRE BENDING SPACE IS PROVIDED FOR UP TO TWO (2) 600MCM CABLES PER TERMINAL PER NEC.
 - OPTIONAL COPPER CRIMP LUGS MAY BE SUPPLIED. UP TO TWO (2) TWO HOLE, LONG BARREL CU CRIMP LUGS RATED FOR UP TO 600MCM. (REFER TO CRIMP LUG INSTALLATION DATA PROVIDED WITH UNIT FOR FULL INSTALLATION DETAILS).
 A. SUITABLE WIRE BENDING SPACE IS PROVIDED FOR UP TO TWO (2) 600MCM CABLES PER TERMINAL PER NEC.
 - GROUND LUGS ARE PROVIDED STANDARD AS FOLLOWS;
 (6) 1/0 - 750MCM CU/AL CABLE CONNECTIONS.

- ### NOTES 800-1000 AMP SWITCHES
- SUPPLIED WITH STANDARD MECHANICAL (SCREW TYPE) LUGS ON THE NORMAL, EMERGENCY & LOAD BUS STABS. ONE (1) LUG PER PHASE AND NEUTRAL EACH SUITABLE FOR CONNECTION OF FOUR (4) 1/0 -750MCM CU/AL CABLE (SEE NOTE "E" BELOW).
 A. SUITABLE WIRE BENDING SPACE IS PROVIDED FOR UP TO FOUR (4) 600MCM CABLES PER TERMINAL PER NEC.
 - OPTIONAL COPPER CRIMP LUGS MAY BE SUPPLIED. UP TO FOUR (4) TWO HOLE, LONG BARREL CU CRIMP LUGS RATED FOR UP TO 600MCM. (REFER TO CRIMP LUG INSTALLATION DATA PROVIDED WITH UNIT FOR FULL INSTALLATION DETAILS).
 A. SUITABLE WIRE BENDING SPACE IS PROVIDED FOR UP TO FOUR (4) 600MCM CABLES PER TERMINAL PER NEC.
 - GROUND LUGS ARE PROVIDED STANDARD AS FOLLOWS;
 (12) 1/0 - 750MCM CU/AL CABLE CONNECTIONS.

- ### NOTES 400A (ADTS "B3" 4 POLE ONLY)
- GROUND LUGS ARE PROVIDED STANDARD AS FOLLOWS;
 (3) #6 - 250MCM CU/AL CABLE CONNECTIONS.

APPROXIMATE SHIPPING WEIGHT, LBS (KG)

SWITCH RATING (AMPS)	POLES	WEIGHTS LB (KG)
600,800	2	419 (190)
600,800	3	442 (201)
(400A 7ADTS) 600,800	4	465 (211)
1000	2	431 (196)
1000	3	460 (209)
1000	4	489 (222)

PROJECT NAME:		245452	WK	BK	11/20/13
REV. TO SHEET	ISSUED	ECN NO.	BY	APP.	DATE
OUTLINE					
300 SERIES					
600-1000 AMP. TYPE 1					
DRAWN BY	DJB	DATE	11/20/13	MANUFACTURING TOLERANCES TO BE IN ACCORDANCE WITH ASCO PROCEDURE MP-1-003. FOR PLASTIC PARTS SEE MP-1-055.	
CHECKED	BK	DATE	11/20/13	ASSEM. REF. NO.	
PROJECT APPROVAL	BK	DATE	11/20/13	PROPERTY OF ASCO POWER TECHNOLOGIES. USE PERMITTED FOR OUR WORK ONLY. ALL RIGHTS OF DESIGN OR INVENTION ARE RESERVED.	
FINAL APPROVAL				COMPUTER GENERATED DRAWING	
				SCALE	NONE
				SIZE	DS
				DWG. NO.	1001394
				DRAWING REV.	ECN NO. 245452 SHEET 1 OF 1

ASCOTM ASCO POWER TECHNOLOGIES, L.P.
 FLORHAM PARK, NEW JERSEY 07932 U.S.A.