

OUTLINE FOR ASCO® 300 SERIES 800-1000 AMPERE "H" FRAME (H3ATS,H3NTS,H3ADTS,H3NDTS) FRONT CONNECTED TRANSFER SWITCHES TYPE 3R, 4, 4X, 12 ENCLOSURE

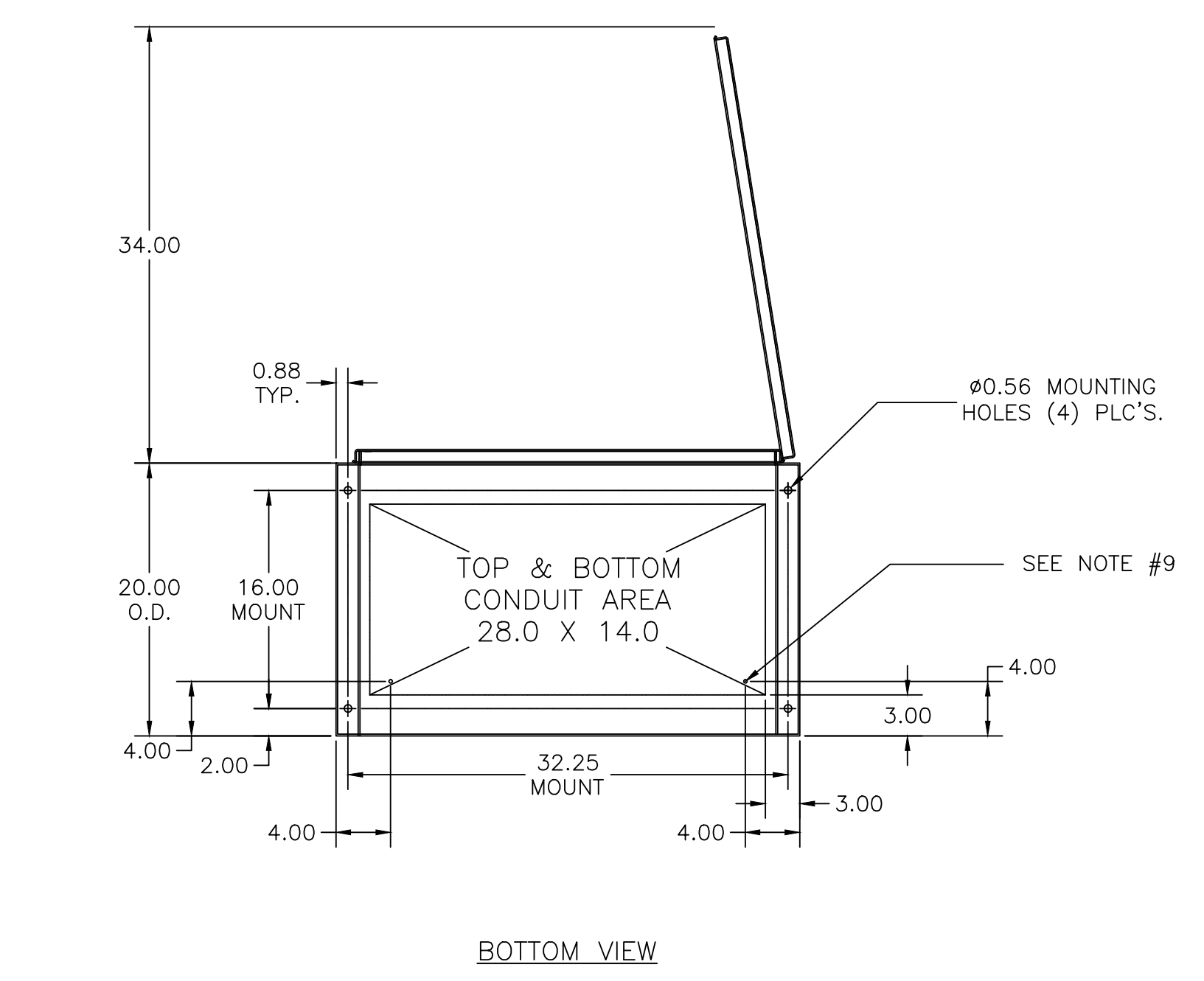
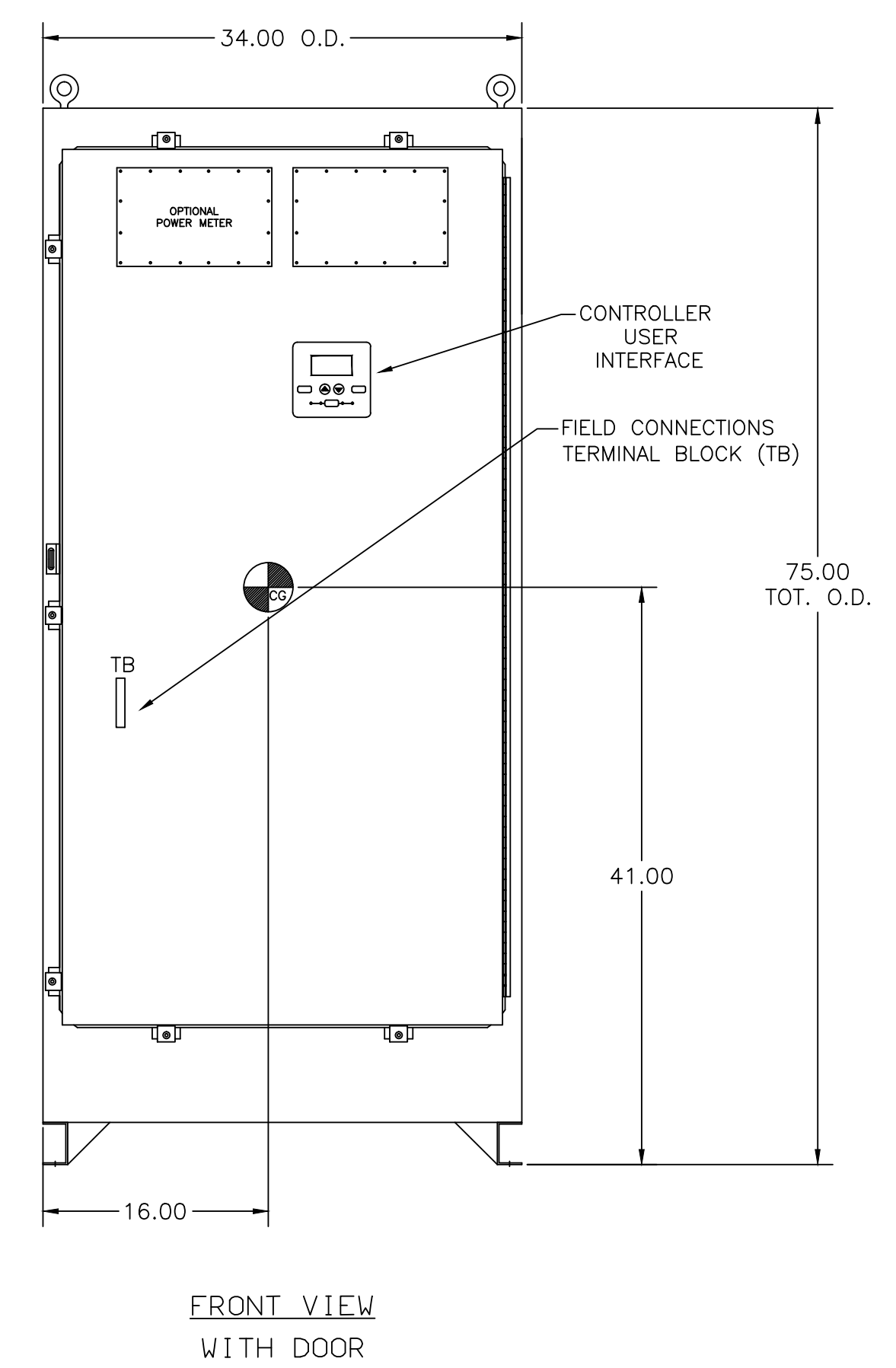
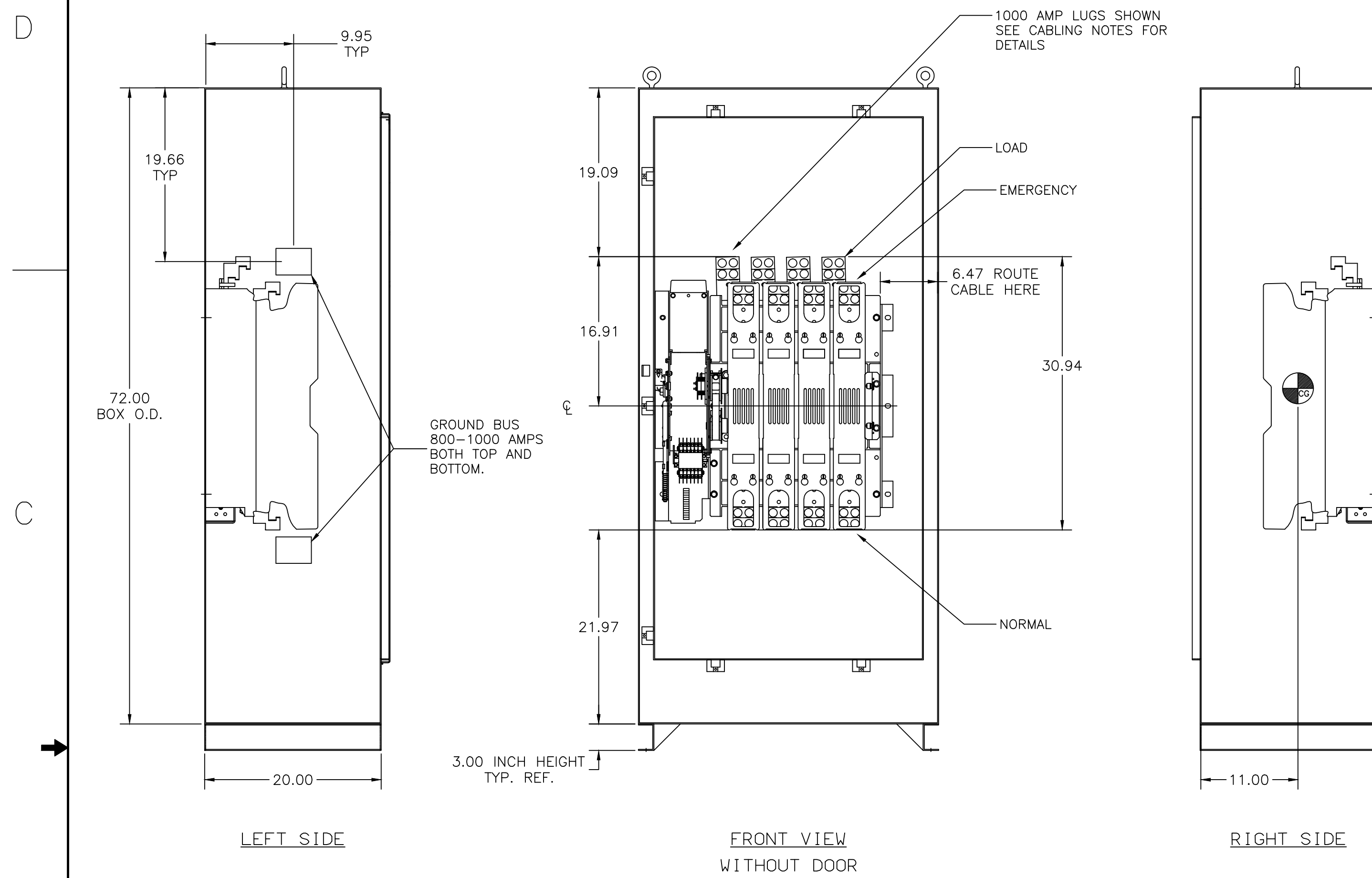

GENERAL NOTES

- TYPE 3R/4/4X/12 ENCLOSURE. FREE STANDING. FLOOR MOUNTED. CODE GAUGE CONSTRUCTION.
- DOOR HINGED ON RIGHT SIDE. LOCKABLE HASP ON LEFT SIDE, DOOR CLAMPS LEFT TOP AND BOTTOM.
- FINISH TYPE 3R/4/12: ANSI 61 GRAY, POLYESTER POWDER STANDARD. OTHER ANSI COLORS AVAILABLE CONSULT FACTORY
TYPE 4X CONSTRUCTED OF 12 GAUGE 304 STAINLESS STEEL.
- RECOMMENDED CLEARANCES:
FRONT: 36 INCHES
- A 20% RATED GROUND BUS IS PROVIDED.
- UNIT IS DESIGNED FOR COMBINATION TOP AND BOTTOM CABLE ENTRY.
- NEUTRAL CONFIGURATIONS:
AN OPTIONAL FULL RATED NEUTRAL CONFIGURATION FOR EACH SOURCE AND THE LOAD MAY BE PROVIDED. WHEN EQUIPPED IT IS IN ONE OF THE FOLLOWING FORMATS AS SPECIFIED BY THE CATALOG NUMBER NO. NEUTRAL TYPE:
(A) SOLID (COPPER BUS) NEUTRAL
(B) SWITCHED NEUTRAL POLE
- CENTER OF GRAVITY
- REMOVE BOTTOM KNOCKOUTS FOR TYPE 3R.

CABLING NOTES

- ALL SIZES SUPPLIED STANDARD WITH MECHANICAL (SCREW TYPE) LUGS. (SEE AMP SIZE BELOW)
A. LUG MATERIAL: ALUMINUM ALLOY 6061-T6 WITH ELECTRO TIN PLATED FINISH.
B. SCREW MATERIAL: ALUMINUM ALLOY 6262-T9 WITH ELECTRO TIN PLATED FINISH.
C. UL LISTED, CSA CERTIFIED.
D. LUG SCREW TIGHTENING TORQUE PER UL 486B: 19 FT.-LBS.
E. SUITABLE WIRE BENDING SPACE IS PROVIDED. (SEE AMP SIZE BELOW)
- GROUND LUGS ARE PROVIDED STANDARD AS FOLLOWS. (SEE AMP SIZE BELOW).

NOTES 800-1000 AMP SWITCHES

- SUPPLIED WITH STANDARD MECHANICAL (SCREW TYPE) LUGS ON THE NORMAL, EMERGENCY & LOAD BUS STABS. ONE (1) LUG PER PHASE AND NEUTRAL EACH SUITABLE FOR CONNECTION OF FOUR (4) 1/0 -750MCM CU/AL CABLE (SEE NOTE "E" BELOW).
A. SUITABLE WIRE BENDING SPACE IS PROVIDED FOR UP TO FOUR (4) 600MCM CABLES PER TERMINAL PER NEC.
- GROUND LUGS ARE PROVIDED STANDARD AS FOLLOWS;
(12) 1/0 - 750MCM CU/AL CABLE CONNECTIONS.

PROJECT NAME:		245213	BWM	SDH	11/4/13	
COMPOSITE OUTLINE		REV. TO SHEET	ECN NO.	BY	APP.	DATE
300 SERIES		NEW ISSUE				
800-1000 AMP, TYPE 3R/4/4X/12		THIRD ANGLE PROJECTION				
DRAWN BY	BY	DATE	MANUFACTURING TOLERANCES TO BE IN ACCORDANCE WITH ASCO PROCEDURE MP-1-003. FOR PLASTIC PARTS SEE MP-1-055.	ASSEM. REF. NO.	COMPUTER GENERATED DRAWING	
CHECKED	BWM	11/4/13	PROPERTY OF ASCO POWER TECHNOLOGIES. USE PERMITTED FOR OUR WORK ONLY. ALL RIGHTS OF DESIGN OR INVENTION ARE RESERVED.		SCALE 1:1 SIZE DS	
PROJECT APPROVAL					DWG. NO. 1001394-002	
FINAL APPROVAL	SDH	11/4/13			DRAWING REV. NO. 245213 SHEET 1 OF 1	

