

# THREE PHASE WIRING FOR ASCO® 300 SERIES TRANSFER SWITCHES (G3ATS/G3NTS) 1000-3000 AMPERES WITH GROUP G CONTROLS

## GENERAL INFORMATION

THIS WIRING APPLIES TO 300 SERIES TRANSFER SWITCHES THAT UTILIZE THE "G" FRAME POWER TRANSFER SWITCH RATED 1000 - 3000 AMPERES.

THE GROUP G CONTROLLER PROVIDES EITHER AUTOMATIC (D3ATS) OR NON-AUTOMATIC [MANUAL] (D3NTS) OPERATION BASED ON ITS FACTORY SETTING ACCORDING TO THE CUSTOMER ORDER REQUIREMENTS.

THE TYPE OF TRANSFER SWITCH PROVIDED CAN BE DETERMINED FROM THE PRODUCT IDENTIFICATION MARKINGS LOCATED ON BOTH THE POWER TRANSFER SWITCH AND THE COVER OF THE GROUP G CONTROLLER.

ALL OPERATIONAL SETTINGS AND SEQUENCES OF THE GROUP G CONTROLLER AND ITS RELATED OPTIONAL ACCESSORIES (1UP, 18RX, 23G) ARE PROVIDED IN THE USER'S GUIDE, ASCO GROUP G CONTROLLER FOR AUTOMATIC & NON-AUTOMATIC TRANSFER SWITCHES, PART NUMBER 381333-400.

INFORMATION FOR INSTALLATION AND TESTING OF THE TRANSFER SWITCH IS PROVIDED IN THE INSTALLATION MANUAL, ASCO 3ATS & 3NTS, D-DESIGN 1000-3000 A TRANSFER SWITCHES, PART NUMBER 381333-406.

### COMMON ALARM & NOT IN AUTO SIGNALING FEATURES

A SET OF FORM C CONTACTS IS PROVIDED ON THE GROUP G CONTROLLER AS "OP1". THE FEATURE SETTING OF "OP1" CAN BE SET TO OPERATE THE CONTACTS AS A "NOT IN AUTO" SIGNAL.

WHEN "OP1" IS SET FOR "NOT IN AUTO", THE OUTPUT CONTACTS CHANGE POSITION WHEN THE TRANSFER IS BEING INHIBITED FROM TRANSFERRING TO THE EMERGENCY SOURCE (FEATURE 34B) OR THE TRANSFER SWITCH HAS BEEN SET FOR NON-AUTOMATIC (MANUAL) OPERATION.

WHEN OPTIONAL ACCESSORY 11BE "SOFTWARE BUNDLE" IS PART OF THE TRANSFER SWITCH ASSEMBLY, "OP1" MAY ALTERNATIVELY SET FOR A "COMMON ALARM" SIGNAL. THE OUTPUT CONTACTS CHANGE POSITION WHEN A "COMMON ALARM" IS NOT PRESENT AND RESET WHEN A "COMMON ALARM" CONDITION IS PRESENT. THE "COMMON ALARM" SIGNAL CONDITIONS ARE SELECTABLE.

ADDITIONAL "COMMON ALARM" AND "NOT IN AUTO" CONTACTS ARE AVAILABLE WHEN OPTIONAL ACCESSORY 18RX (RELAY EXPANSION MODULE) IS INCLUDED IN THE TRANSFER SWITCH ASSEMBLY. OUTPUT CONTACTS "OP2 AND/OR "OP3" WILL PROVIDE SIGNAL FUNCTIONS WHEN THE FEATURE SETTING OF EACH IS SET TO OPERATE AS "COMMON ALARM" OR "NOT IN AUTO".

CONTACTS ARE RATED 5 AMPS RESISTIVE AT 30 VDC MAXIMUM, 100 mA AT 5 VDC MINIMUM.

REFER TO USER'S GUIDE, ASCO GROUP G CONTROLLER FOR AUTOMATIC & NON-AUTOMATIC TRANSFER SWITCHES, PART NUMBER 381333-400 FOR SETTING INFORMATION.

### NON-AUTOMATIC (MANUAL) OPERATION

TRANSFER SWITCH ASSEMBLIES FACTORY SET FOR NON-AUTOMATIC OPERATION PROVIDE USER INITIATED, ELECTRICAL OPERATION OF THE TRANSFER SWITCH TO EITHER AVAILABLE SOURCE. THE TRANSFER SWITCH ASSEMBLY IS PHYSICALLY IDENTICAL TO THAT OF THE AUTOMATIC TYPE.

WHEN THE TRANSFER SWITCH IS SET FOR NON-AUTOMATIC OPERATION, A CUSTOMER PROVIDED SELECTOR SWITCH MAY BE USED TO OPERATE IT FROM A REMOTE LOCATION.

### REMOTE CONTROL FEATURES

THE FOLLOWING CONTROL PANEL INPUTS PROVIDE REMOTE CONTROL FUNCTIONS FOR THE TRANSFER SWITCH. EACH FUNCTION CAN BE IMPLEMENTED BY THE CUSTOMER PROVIDING THE FORM OF CONTROL DESCRIBED. EACH CONTROL CONTACT MUST BE SUITABLE FOR A 5 VDC LOW ENERGY CIRCUIT.

EXTERNAL FEATURE 17: REMOTE TRANSFER TO EMERGENCY FEATURE (FOR AUTOMATIC TRANSFER TYPE ONLY) - REQUIRES A CUSTOMER SUPPLIED, NORMALLY CLOSED CONTACT. OPENING OF THE CONTACT CAUSES ENGINE START AND TRANSFER TO THE EMERGENCY SOURCE. RE-CLOSURE OF THE CONTACT ACTIVATES THE FEATURE 3A "RETRANSFER TO NORMAL (IF JUST TEST) TIME DELAY PRIOR TO RETRANSFER. IN THE EVENT THAT THE EMERGENCY SOURCE FAILS WHILE THE TRANSFER SWITCH IS CONNECTED TO EMERGENCY AND THE CUSTOMER SUPPLIED CONTACT IS OPEN, THE TRANSFER SWITCH WILL AUTOMATICALLY RETRANSFER TO THE NORMAL SOURCE.

EXTERNAL FEATURE 6B: REMOTE BYPASS OF RETRANSFER TO NORMAL TIME DELAY - REQUIRES A CUSTOMER SUPPLIED, NORMALLY CLOSED CONTACT. OPENING OF THE CONTACT BYPASSES FEATURE 3A RETRANSFER TO NORMAL DELAY IF ACTIVE.

REFER TO USER'S GUIDE, ASCO GROUP G CONTROLLER FOR AUTOMATIC & NON-AUTOMATIC TRANSFER SWITCHES, PART NUMBER 381333-400 FOR SETTING INFORMATION.

### ENGINE CONTROL CONTACTS

FEATURE 7 & FEATURE 8:  
ONE SET OF FORM C CONTACTS "NR" (FEAT. 7 N/C, FEAT. 8 N/O) THAT CHANGE POSITION ON EXPIRATION OF THE FEATURE 1C, OVERRIDE MOMENTARY NORMAL SOURCE OUTAGES TIME DELAY, AND RESET ON EXPIRATION OF THE FEATURE 2E ENGINE COOLDOWN TIME DELAY.

AN AUXILIARY CONTACT THAT IS CLOSED WHEN THE TRANSFER SWITCH IS CONNECTED TO THE EMERGENCY SOURCE, IS CONNECTED ACROSS THE N/C CONTACT (FEATURE 7).

AN ADDITIONAL SET OF ENGINE STARTING CONTACTS ARE AVAILABLE ON THE GROUP G CONTROLLER WHEN THE FEATURE SETTING OF THE CONTROLLER OUTPUT CONTACTS "OP1" IS SET TO OPERATE AS "NR2".

ADDITIONAL, OPTIONAL ENGINE STARTING CONTACTS "NR2" ARE AVAILABLE WHEN OPTIONAL ACCESSORY 18RX (RELAY EXPANSION MODULE) IS INCLUDED IN THE TRANSFER SWITCH ASSEMBLY. OUTPUT CONTACTS "OP2" AND/OR "OP3" PROVIDE THE ENGINE STARTING FUNCTION WHEN THE FEATURE SETTING OF EACH IS SET TO OPERATE AS "NR2".

CONTACTS ARE RATED 5 AMPS RESISTIVE AT 30 VDC MAXIMUM, 100 mA AT 5 VDC MINIMUM.

REFER TO USER'S GUIDE, ASCO GROUP G CONTROLLER FOR AUTOMATIC & NON-AUTOMATIC TRANSFER SWITCHES, PART NUMBER 381333-400 FOR SETTING INFORMATION.

### EXTERNAL POWER SUPPLY COMPATIBILITY

USE OF AN EXTERNAL POWER SUPPLY IS USEFUL WHEN REQUIRED TO EXTEND THE FOLLOWING CONTROLLER TIME DELAYS BEYOND 6 SECONDS:

FEATURE 1C - OVERRIDE MOMENTARY NORMAL SOURCE OUTAGES  
FEATURE 1F - OVERRIDE MOMENTARY EMERGENCY SOURCE OUTAGES

AN EXTERNAL POWER SUPPLY IS ALSO USEFUL WHEN THE TRANSFER SWITCH IS USED WITH COMMUNICATIONS FEATURES BY ENABLING THE CONTROLLER TO CONTINUE COMMUNICATING.

AN EXTERNAL POWER SOURCE MAY BE PROVIDED TO THE CONTROLLER, UNTIL THE NORMAL SOURCE OR EMERGENCY SOURCE IS AVAILABLE, BY USE OF:

- AN EXTERNAL 24 VDC POWER SUPPLY WITH ACCESSORY 18RX (RELAY EXPANSION MODULE) OR
- OPTIONAL ACCESSORY 1UP (UNINTERRUPTIBLE POWER SUPPLY MODULE)

### LOAD DISCONNECT FEATURE

FEATURE 31: INCLUDES SUB-FEATURES 31F, 31G, 31M, 31N  
A SET OF FORM C CONTACTS ARE PROVIDED ON THE GROUP G CONTROLLER AS "OP1". WHEN THE FEATURE SETTING OF "OP1" IS SET TO OPERATE THE CONTACTS AS "FEATURE 31", THE TIME DELAY SETTINGS OF THE SUB-FEATURES ARE AVAILABLE.

"OP1" CAN BE SET TO OPERATE TO PROVIDE THE FOLLOWING FUNCTIONS USING THE TIME DELAY SETTINGS ASSOCIATED WITH EACH SUB-FEATURE:

31F - NORMAL TO EMERGENCY PRE-TRANSFER SIGNAL  
31G - EMERGENCY TO NORMAL PRE-TRANSFER SIGNAL  
31M - NORMAL TO EMERGENCY POST-TRANSFER SIGNAL  
31N - EMERGENCY TO NORMAL POST-TRANSFER SIGNAL

THE "OP1" OUTPUT CONTACTS CHANGE POSITION FOLLOWING EACH OF THE ABOVE TIME DELAYS.

ADDITIONAL LOAD DISCONNECT CONTACTS, "FEATURE 31" ARE AVAILABLE WHEN OPTIONAL ACCESSORY 18RX (RELAY EXPANSION MODULE) IS INCLUDED IN THE TRANSFER SWITCH ASSEMBLY. OUTPUT CONTACTS "OP2 AND/OR "OP3" WILL PROVIDE LOAD DISCONNECT FUNCTIONS WHEN THE FEATURE SETTING OF EACH IS SET TO OPERATE AS "FEATURE 31".

ALL OUTPUT CONTACTS ("OP1", "OP2", "OP3") SET TO OPERATE AS "FEATURE 31", SHARE THE COMMON TIME DELAY SETTINGS OF SUB-FEATURES 31F, 31G, 31M, AND 31N.

CONTACTS ARE RATED 5 AMPS RESISTIVE AT 30 VDC MAXIMUM, 100 mA AT 5 VDC MINIMUM.

REFER TO USER'S GUIDE, ASCO GROUP G CONTROLLER FOR AUTOMATIC & NON-AUTOMATIC TRANSFER SWITCHES, PART NUMBER 381333-400 FOR SETTING INFORMATION.

### LOAD CURRENT METERING

WHEN OPTIONAL ACCESSORY 23GB IS PART OF THE TRANSFER SWITCH ASSEMBLY, THREE PHASE CURRENT MEASUREMENTS ARE AVAILABLE FOR DISPLAY ON THE GROUP G CONTROLLER.

REFER TO USER'S GUIDE, ASCO GROUP G CONTROLLER FOR AUTOMATIC & NON-AUTOMATIC TRANSFER SWITCHES, PART NUMBER 381333-400 FOR INFORMATION ON USE.

### FOUR-FUNCTION SOFTWARE BUNDLE

WHEN OPTIONAL ACCESSORY 11BE IS PART OF THE TRANSFER SWITCH ASSEMBLY, A FOUR-FUNCTION SOFTWARE BUNDLE IS AVAILABLE TO PERFORM THE FOLLOWING FUNCTIONS:

- SERIAL COMMUNICATIONS (RS-485)
- PROGRAMMABLE ENGINE EXERCISER
- EVENT LOG
- COMMON ALARM SIGNAL CAPABILITY ON GROUP G CONTROLLER "OP1" OUTPUT.

REFER TO USER'S GUIDE, ASCO GROUP G CONTROLLER FOR AUTOMATIC & NON-AUTOMATIC TRANSFER SWITCHES, PART NUMBER 381333-400 FOR INFORMATION ON THESE FUNCTIONS.

### LOAD DISCONNECT FEATURE

FEATURE 31: INCLUDES SUB-FEATURES 31F, 31G, 31M, 31N  
A SET OF FORM C CONTACTS ARE PROVIDED ON THE GROUP G CONTROLLER AS "OP1". WHEN THE FEATURE SETTING OF "OP1" IS SET TO OPERATE THE CONTACTS AS "FEATURE 31", THE TIME DELAY SETTINGS OF THE SUB-FEATURES ARE AVAILABLE.

"OP1" CAN BE SET TO OPERATE TO PROVIDE THE FOLLOWING FUNCTIONS USING THE TIME DELAY SETTINGS ASSOCIATED WITH EACH SUB-FEATURE:

31F - NORMAL TO EMERGENCY PRE-TRANSFER SIGNAL  
31G - EMERGENCY TO NORMAL PRE-TRANSFER SIGNAL  
31M - NORMAL TO EMERGENCY POST-TRANSFER SIGNAL  
31N - EMERGENCY TO NORMAL POST-TRANSFER SIGNAL

THE "OP1" OUTPUT CONTACTS CHANGE POSITION FOLLOWING EACH OF THE ABOVE TIME DELAYS.

ADDITIONAL LOAD DISCONNECT CONTACTS, "FEATURE 31" ARE AVAILABLE WHEN OPTIONAL ACCESSORY 18RX (RELAY EXPANSION MODULE) IS INCLUDED IN THE TRANSFER SWITCH ASSEMBLY. OUTPUT CONTACTS "OP2 AND/OR "OP3" WILL PROVIDE LOAD DISCONNECT FUNCTIONS WHEN THE FEATURE SETTING OF EACH IS SET TO OPERATE AS "FEATURE 31".

ALL OUTPUT CONTACTS ("OP1", "OP2", "OP3") SET TO OPERATE AS "FEATURE 31", SHARE THE COMMON TIME DELAY SETTINGS OF SUB-FEATURES 31F, 31G, 31M, AND 31N.

CONTACTS ARE RATED 5 AMPS RESISTIVE AT 30 VDC MAXIMUM, 100 mA AT 5 VDC MINIMUM.

REFER TO USER'S GUIDE, ASCO GROUP G CONTROLLER FOR AUTOMATIC & NON-AUTOMATIC TRANSFER SWITCHES, PART NUMBER 381333-400 FOR SETTING INFORMATION.

### INPHASE TRANSFER FEATURE FOR LOAD TRANSFER

INPHASE TRANSFER CONTROL INITIATES AN INPHASE TRANSFER OF LOADS BETWEEN LIVE SOURCES. THIS IS USED TO PREVENT NUISANCE TRIPPING OF DISTRIBUTION CIRCUIT BREAKERS AND POSSIBLE DAMAGE TO MECHANICAL LOADS ASSOCIATED WITH OUT OF PHASE TRANSFER.

REFER TO USER'S GUIDE, ASCO GROUP G CONTROLLER FOR AUTOMATIC & NON-AUTOMATIC TRANSFER SWITCHES, PART NUMBER 381333-400 FOR SETTING INFORMATION.

### SOURCE AVAILABILITY SIGNALS

SIGNALS INDICATING THE AVAILABILITY OF THE NORMAL & EMERGENCY SOURCES IS PROVIDED WHEN OPTIONAL ACCESSORY 18RX (RELAY EXPANSION MODULE) IS INCLUDED IN THE TRANSFER SWITCH ASSEMBLY. OUTPUT CONTACTS "RL5" (EMERGENCY SOURCE AVAILABLE) AND "RL6" (NORMAL SOURCE AVAILABLE) CHANGE POSITION WHEN THE SOURCE IS ACCEPTABLE.

CONTACTS ARE RATED 5 AMPS RESISTIVE AT 30 VDC MAXIMUM, 100 mA AT 5 VDC MINIMUM.

## NOTES

1. SWITCH SHOWN DE-ENERGIZED CONNECTED TO NORMAL SOURCE.
2. DEVICE SYMBOLS AND DESIGNATIONS WITH NEMA PUB. ICS 1, PART 1-101A.
3. ALL WIRING IS #16 AWG, TINNED, STRANDED COPPER UNLESS OTHERWISE INDICATED.
4. O INDICATES CUSTOMER CONNECTION POINTS.
5. ● INDICATES FACTORY CONNECTION POINTS.
6. CONNECTION POINTS THAT HAVE BOTH CUSTOMER CONNECTIONS AND FACTORY CONNECTIONS ARE SHOWN OPEN AS CUSTOMER CONNECTION POINTS.
7. THE TRANSFER UNIT IS MOUNTED ON THE BACK INSIDE SURFACE OF THE ENCLOSURE. THE CONTROL PANEL AND ANY OPTIONAL ACCESSORIES ARE MOUNTED ON THE INSIDE SURFACE OF THE DOOR.
8. AN OPERATOR'S MANUAL IS FURNISHED WITH EACH AUTOMATIC TRANSFER SWITCH. REFER TO THIS PUBLICATION PRIOR TO INSTALLATION AND OPERATION OF THE SWITCH.
9. GROUND STRAP ON CONTROL PANEL IS AFFIXED TO CHASSIS (ENCLOSURE) AT LOWER LEFT CONTROL PANEL MOUNTING STUD.

CATALOG NUMBER SUFFIXES										EXPLANATION OF CATALOG NUMBER CODES													
TS FRAME	CATALOG TYPE	NEUTRAL TYPE	PHASE POLES	AMPS	VOLT CODE	CONTROLLER	OPTIONAL ACCESSORY	ENCLOSURE CODE		NEUTRAL TYPE	VOLTAGE CODES	ENCLOSURE CODES											
										CODE	DESCRIPTION	CODE	NOMINAL VOLTAGE	CODE	TYPE	DESCRIPTION							
G	3ATS	A	3	1000	C	G	X	C		A	SOLID SWITCHING	C	208	BLANK	1	OPEN TYPE (NO ENCLOSURE) GENERAL PURPOSE, INDOOR							
		B		1200	D			D		B		E	220	F	3R	OUTDOOR, RAINPROOF, SLEET & ICE RESISTANT							
				1600	E			E		G		F	230	G	4	INDOOR/OUTDOOR, WATERTIGHT & DUSTTIGHT							
				2000	F			F		H		G	240	H	4X	TYPE 4 PLUS CORROSION RESISTANCE (STAINLESS STEEL)							
				2600	G			G		L		H	277	L	12	INDOOR, INDUSTRIAL ENVIRONMENTS, OILTIGHT & DUSTTIGHT							
				3000	H			H				J	380			(SECURE ENCLOSURES)							
					I			I				K	400			OUTDOOR, RAINPROOF, SLEET & ICE RESISTANT							
					J			J				L	415	M	3R	INDOOR/OUTDOOR, WATERTIGHT & DUSTTIGHT							
					K			K				M	440	N	4	TYPE 4 PLUS CORROSION RESISTANCE (STAINLESS STEEL)							
					L			L				N	460	P	4X	INDOOR, INDUSTRIAL ENVIRONMENTS, OILTIGHT & DUSTTIGHT							
					M			M				P	480	Q	12								
					N			N				Q	550										
					O			O					575										
					P			P					600										
					Q			Q															

CATALOG NUMBER \_\_\_\_\_  
 ASCO® S.O. \_\_\_\_\_  
 BY \_\_\_\_\_  
 DATE \_\_\_\_\_

FORM REV - \_\_\_\_\_  
 ISSUE \_\_\_\_\_  
 ECN NO. \_\_\_\_\_ BY APP. \_\_\_\_\_ DATE \_\_\_\_\_

PROJECT NAME: \_\_\_\_\_  
 WIRING \_\_\_\_\_  
 300 SERIES (G3A/NTS) 3PH 1000-3000 AMPS  
 "G" FRAME, GROUP G CONTROLS

SCALE NONE SIZE DS  
 DWG. NO. 1001662  
 DRAWING REV. \_\_\_\_\_ ECN NO. 245072 SHEET 1 OF 7

ASCO® ASCO POWER TECHNOLOGIES, L.P.  
 FLORENCE PARK, NEW JERSEY 07932 U.S.A.



# FIELD CONNECTIONS

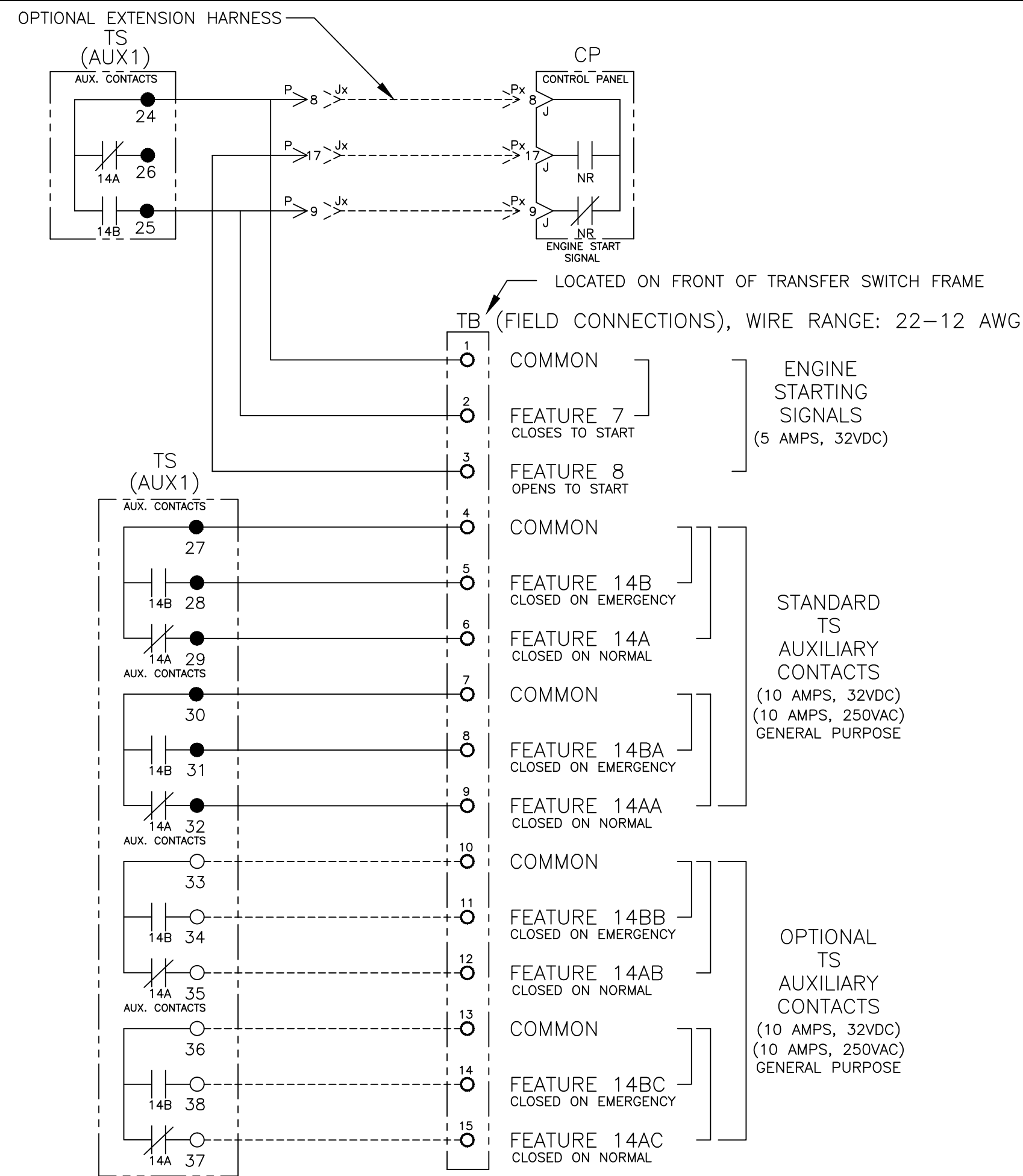

**CONTROLLER OPTION RELAY "OP1" (STANDARD)**

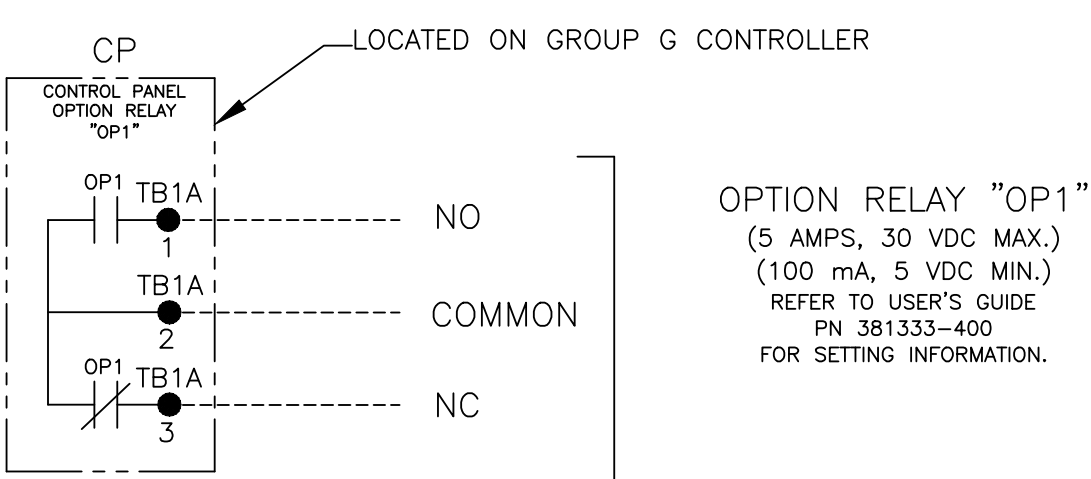

**CONTROLLER REMOTE CONTROL FEATURES**

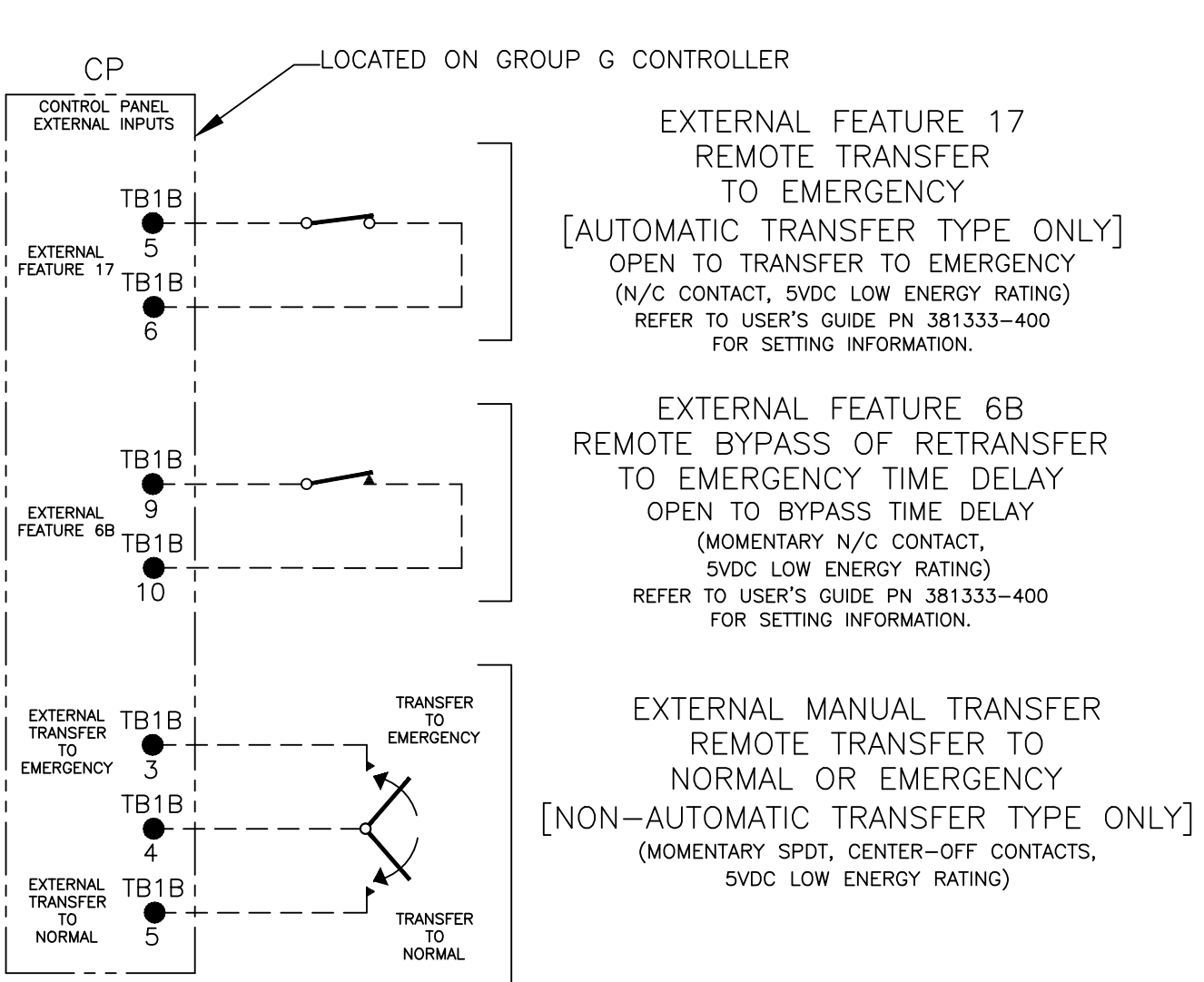

**OPTIONAL ACCESSORY 18RX (RELAY EXPANSION MODULE)**

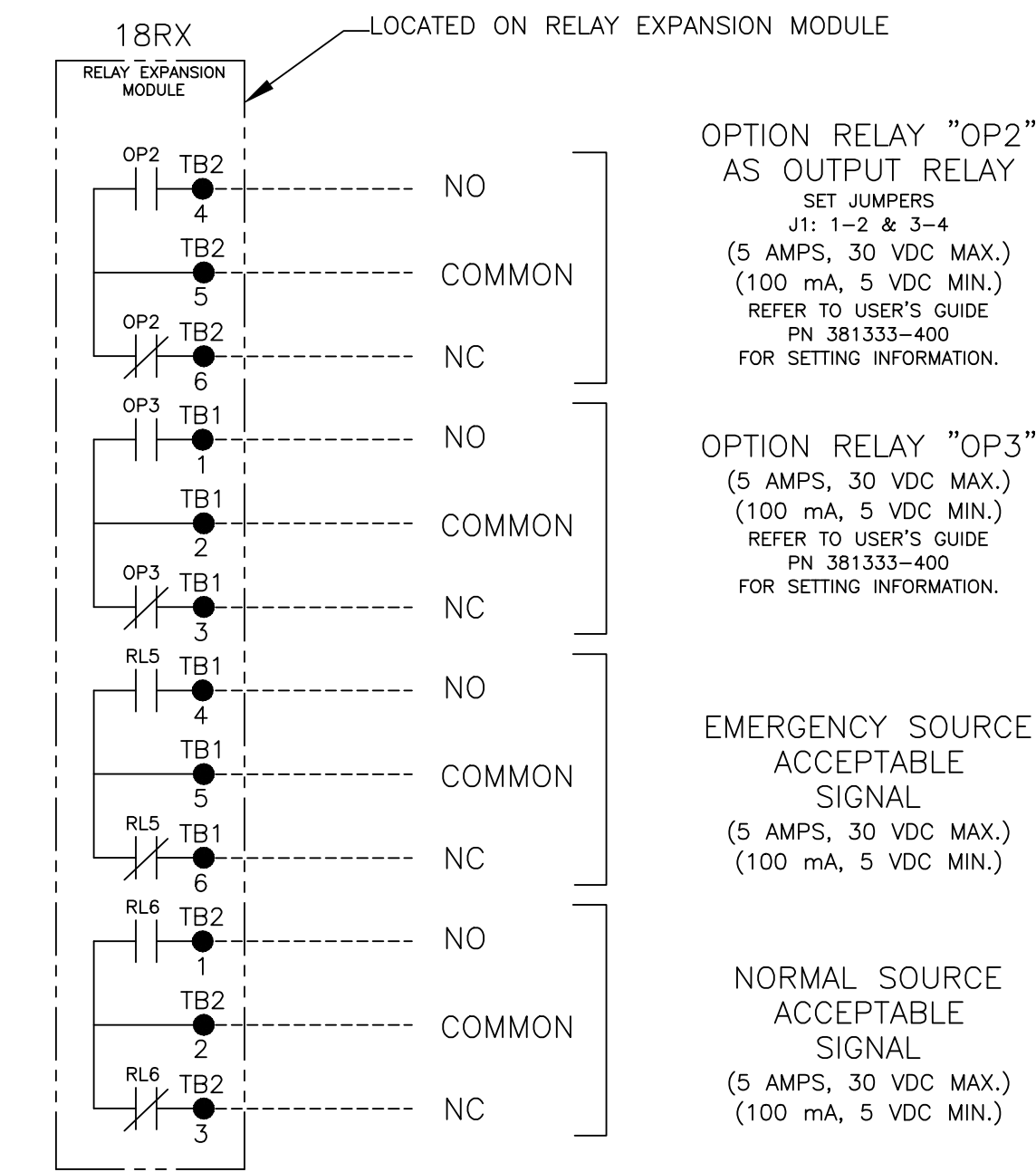

"OP2" OPTIONAL USES

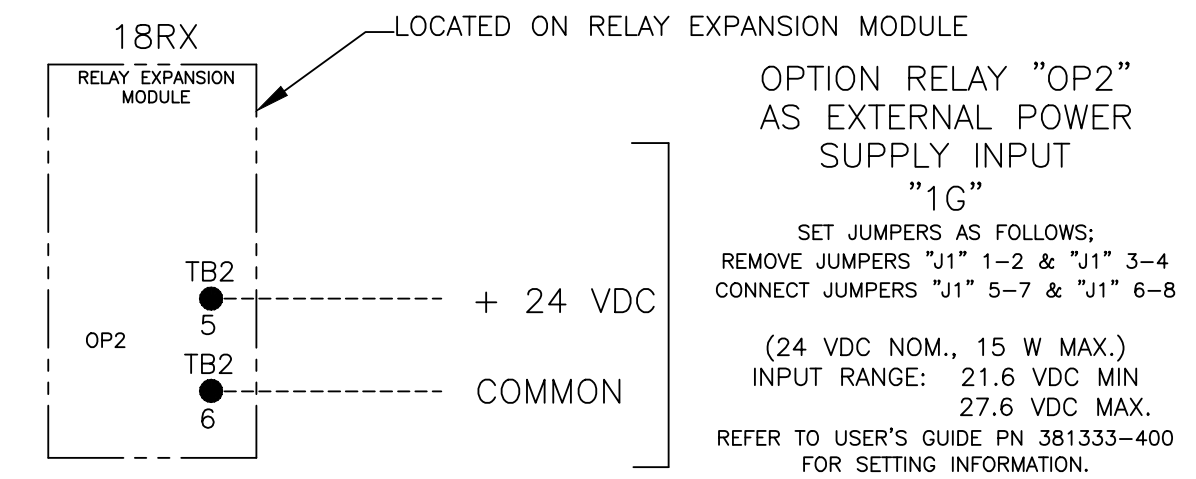

**OPTIONAL ACCESSORY 18RX1 (SECOND RELAY EXPANSION MODULE)**

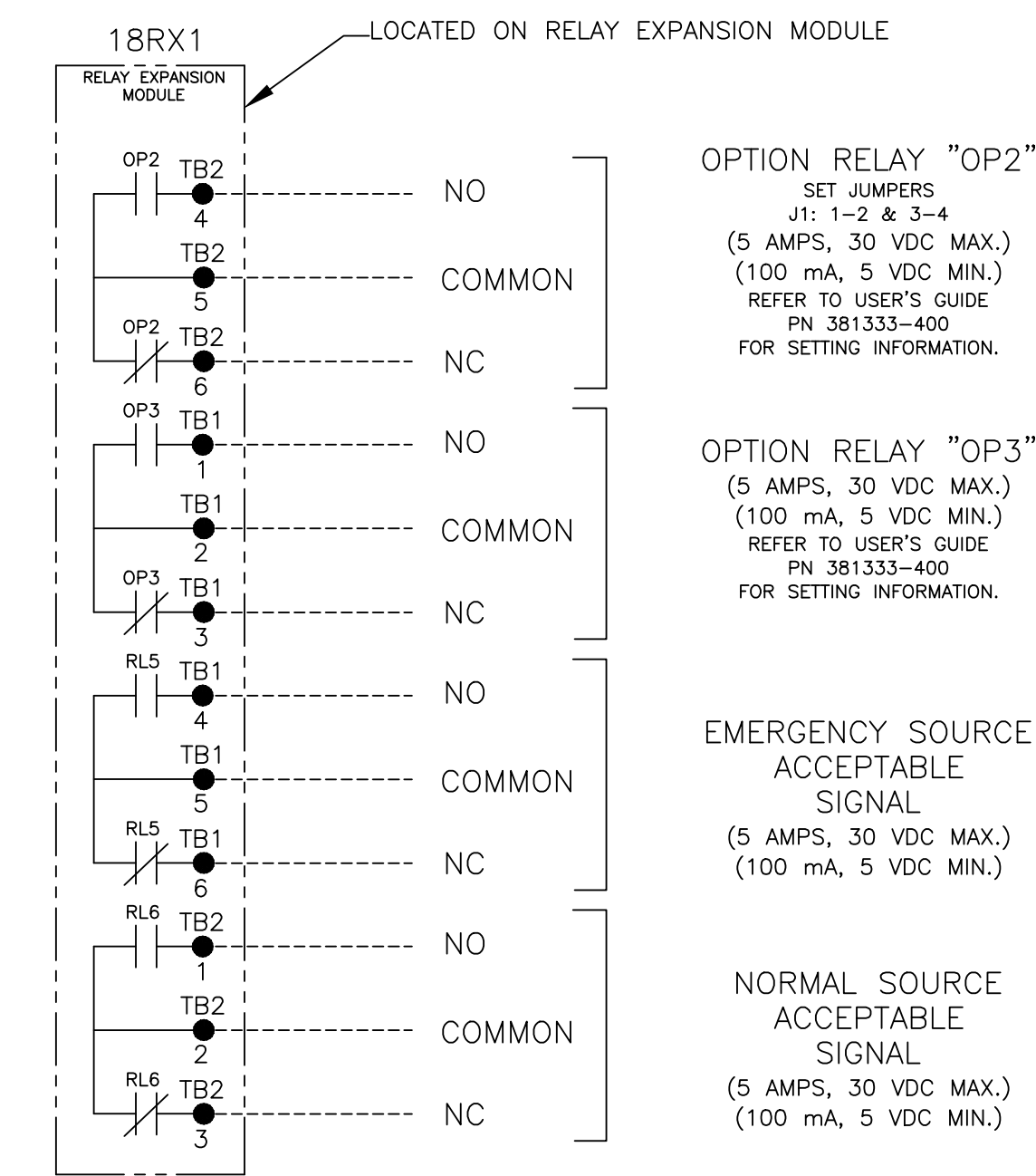

PROJECT NAME:		245072	BK	BK	10/28/13
WIRING DIAGRAM		ISSUE	BY	APP.	DATE
300 SERIES (G3A/NTS) 3PH 1000-3000 AMPS "G" FRAME, GROUP G CONTROLS		THIRD ANGLE PROJECTION			
DRAWN BY	DJB	DATE	10/28/13	ASSEMBLY REF. NO.	
CHECKED	BK	DATE	10/28/13	PROPERTY OF ASCO POWER TECHNOLOGIES. USE PERMITTED FOR OUR WORK ONLY. ALL RIGHTS OF DESIGN OR INVENTION ARE RESERVED.	SCALE NONE SIZE DS
PROJECT APPROVAL	BK	DATE	10/28/13	COMPUTER GENERATED DRAWING	DWG. NO. 1001662
FINAL APPROVAL		DATE		ASCO® ASCO POWER TECHNOLOGIES, L.P. FLORHAM PARK, NEW JERSEY 07932 U.S.A.	DRAWING NO. 245072 SHEET 2 OF 7

MAIN POWER POLES

TS OPERATOR CIRCUIT

EMERGENCY

NORMAL

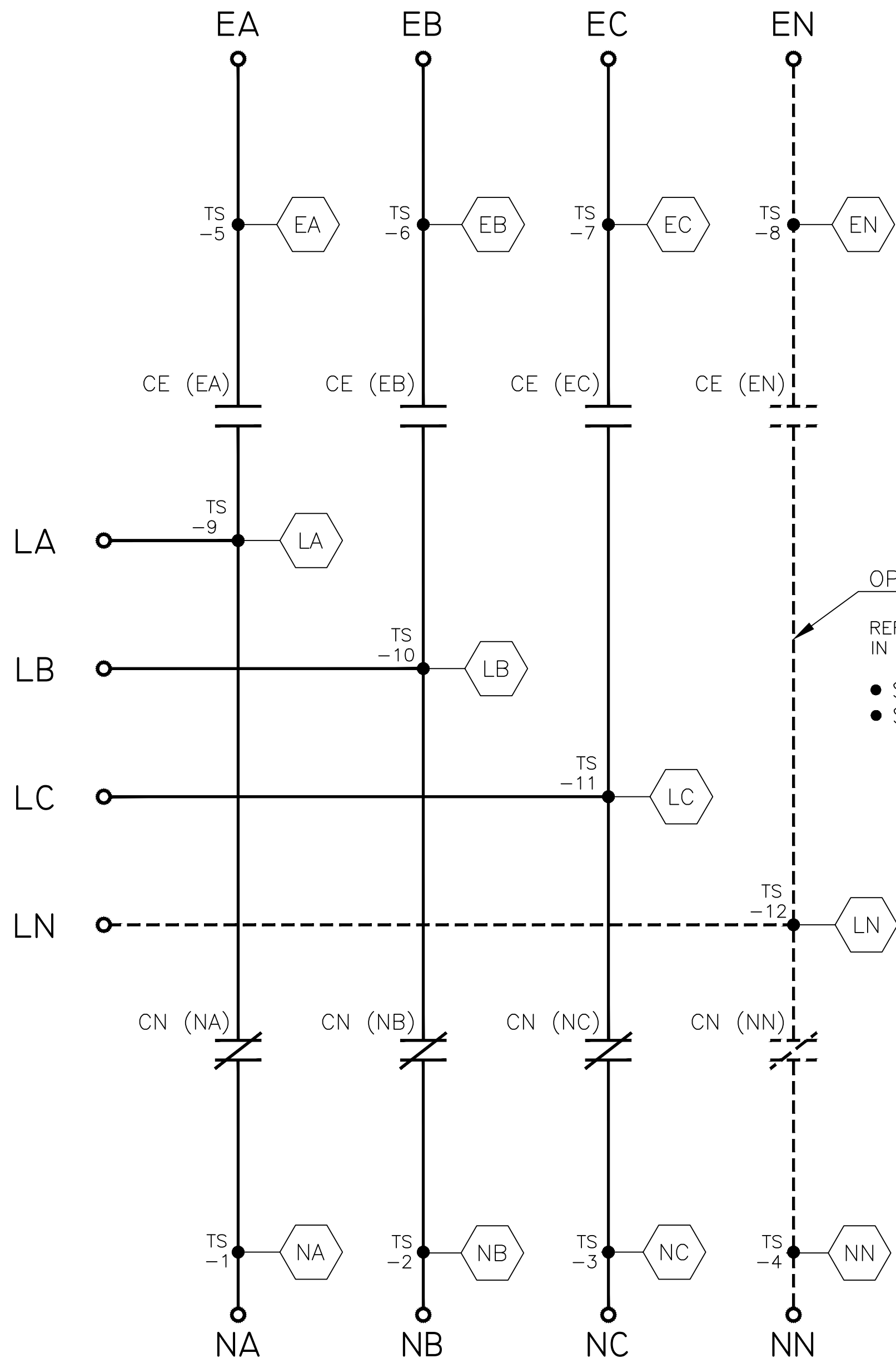

OPTIONAL NEUTRAL TYPES  
 REFER TO "EXPLANATION OF CATALOG NUMBER CODES"  
 IN CATALOG NUMBER CHART ON SHEET 1.

- SOLID BUS PLATE
- SWITCHING

NOTE:  
 ATS/NTS SHOWN CLOSED ON NORMAL SOURCE.

LOAD

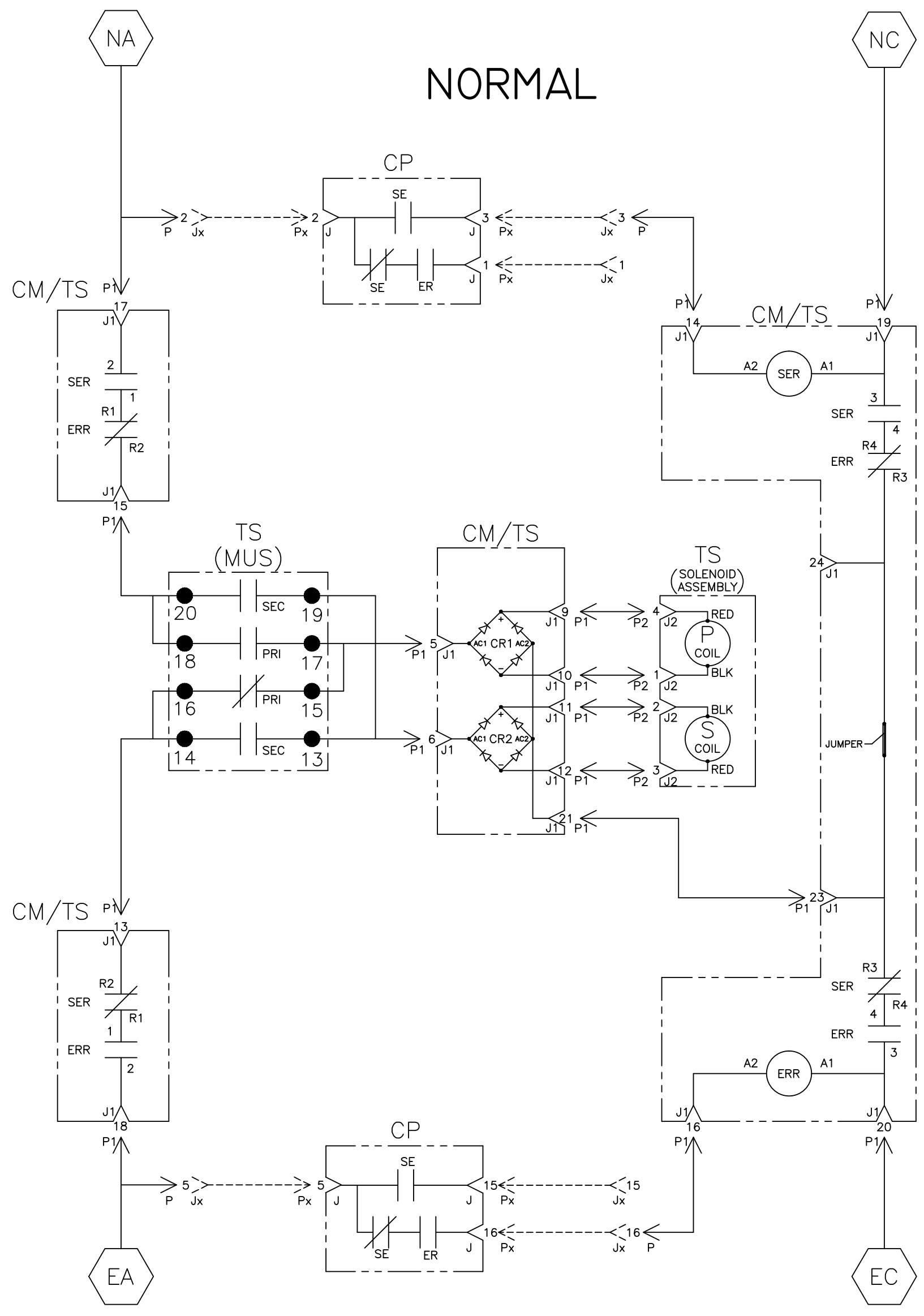

EMERGENCY

TS (MUS) CONTACTS		SOLENOID POSITION			
MUS	NORM	>	AFTER TDC	<	EMER
13-14					
15-16					
17-18					
19-20					

\* AFTER SOLENOID PASSES THROUGH TOP DEAD CENTER POSITION.

PROJECT NAME: \_\_\_\_\_

WIRING \_\_\_\_\_ DIAGRAM \_\_\_\_\_

300 SERIES (G3A/NTS) 3PH 1000-3000 AMPS  
 "G" FRAME, GROUP G CONTROLS

BY	DATE	MANUFACTURING TOLERANCES TO BE IN ACCORDANCE WITH ASCO PROCEDURE MP-1-003. FOR PLASTIC PARTS SEE MP-1-055.	ASSEM. REF. NO.
DRAWN BY	DJB 10/28/13		
CHECKED	BK 10/28/13	PROPERTY OF ASCO POWER TECHNOLOGIES. USE PERMITTED FOR OUR WORK ONLY. ALL RIGHTS OF DESIGN OR INVENTION ARE RESERVED.	
PROJECT APPROVAL	BK 10/28/13		
FINAL APPROVAL			

SCALE NONE SIZE DS

COMPUTER GENERATED DRAWING

DWG. NO. 1001662

ASCO POWER TECHNOLOGIES, L.P.  
 FLORHAM PARK, NEW JERSEY 07932 U.S.A.

DRAWING REV. NO. 245072 SHEET 3 OF 7

EMERGENCY SOURCE CIRCUITS

NORMAL

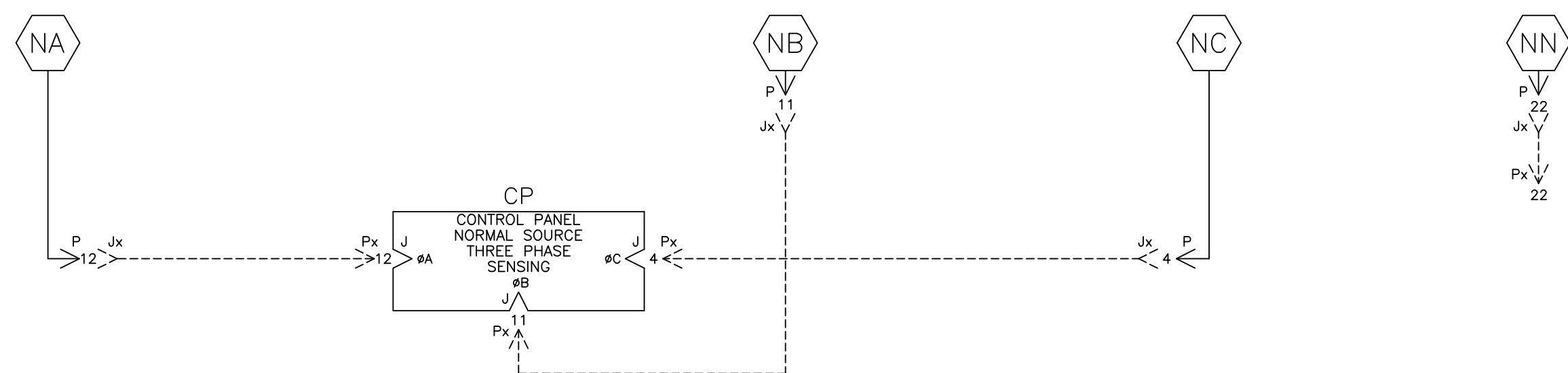

EMERGENCY SOURCE CIRCUITS

EMERGENCY

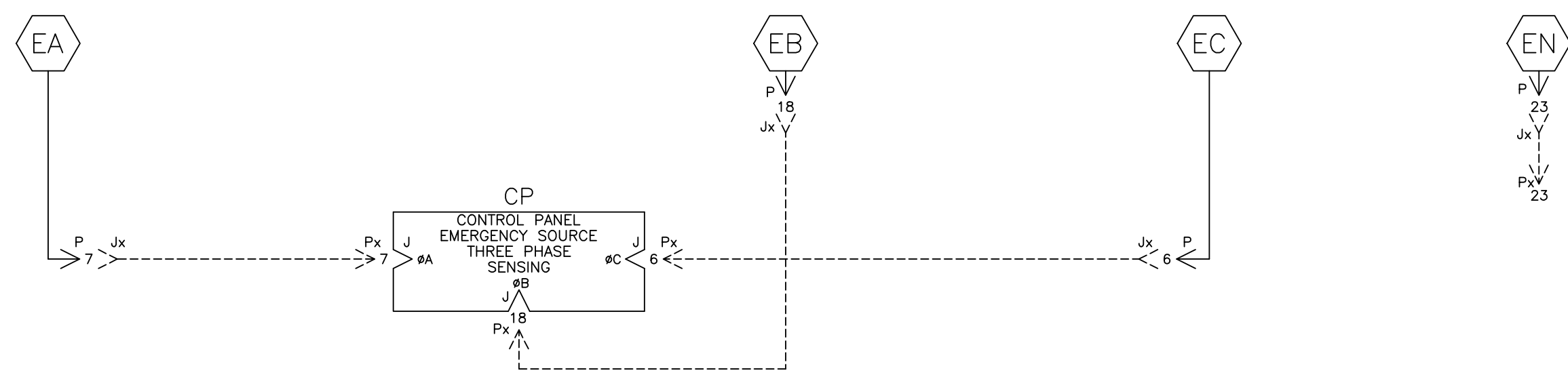

LOAD TERMINAL CIRCUITS

LOAD



CONTROL SIGNALS & INDICATION

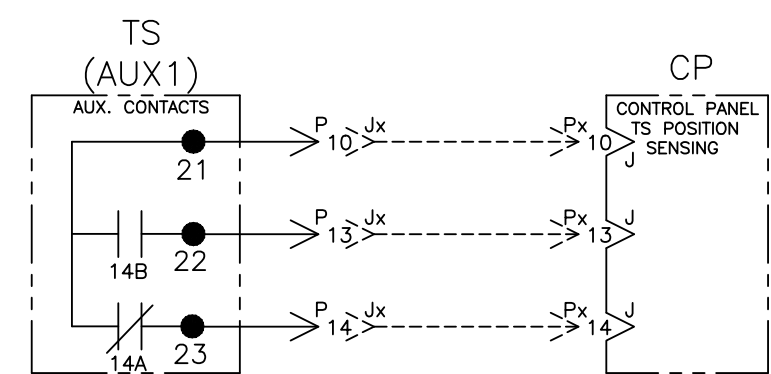

ADDITIONAL CIRCUITS

OPTIONAL ACCESSORY 23GB (LOAD CURRENT METERING)

SWITCH RATING	CT RATIO
1000A	1200:5A
1200A	1200:5A
1600A	2000:5A
2000A	2000:5A
2600A	3000:5A
3000A	3000:5A

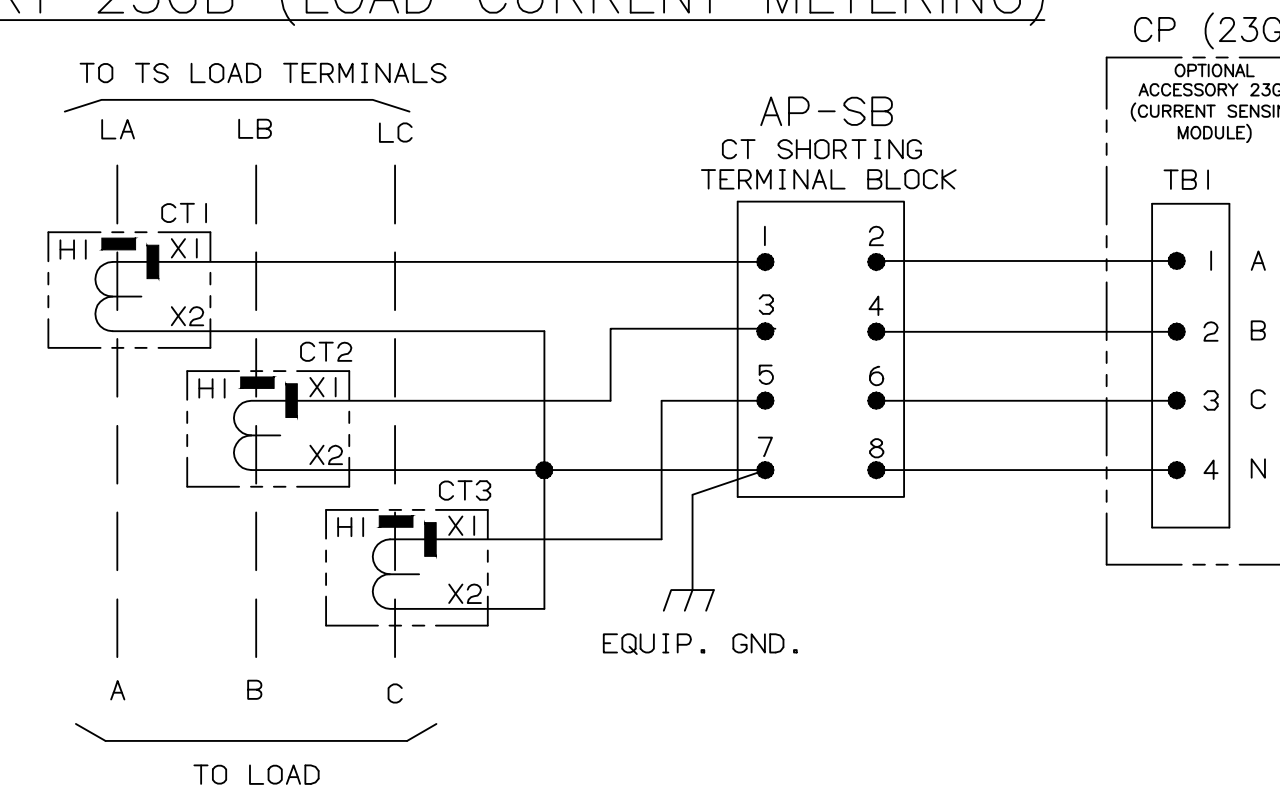

PROJECT NAME:		245072	BK	BK	10/28/13
WIRING		ISSUE	ECN NO.	BY	APP.
300 SERIES (G3A/NTS) 3PH 1000-3000 AMPS		SCALE	NONE	SIZE	DS
"G" FRAME, GROUP G CONTROLS		DWG. NO.	1001662		
BY	DATE	ASSEMBLY REF. NO.	COMPUTER GENERATED DRAWING		
DJB	10/28/13	PROPERTY OF ASCO POWER TECHNOLOGIES, L.P. USE PERMITTED FOR OUR WORK ONLY. ALL RIGHTS OF DESIGN OR INVENTION ARE RESERVED.	DRAWING NO. 245072		
CHECKED	BK	10/28/13	SHEET 4 OF 7		
PROJECT APPROVAL	BK	10/28/13	REV. NO. 245072		
FINAL APPROVAL			REV. NO. 245072		

ASCO POWER TECHNOLOGIES, L.P.  
FLORHAM PARK, NEW JERSEY 07932 U.S.A.



PHYSICAL DIAGRAM

ENCLOSURE

DOOR, INSIDE

TS (TRANSFER SWITCH)

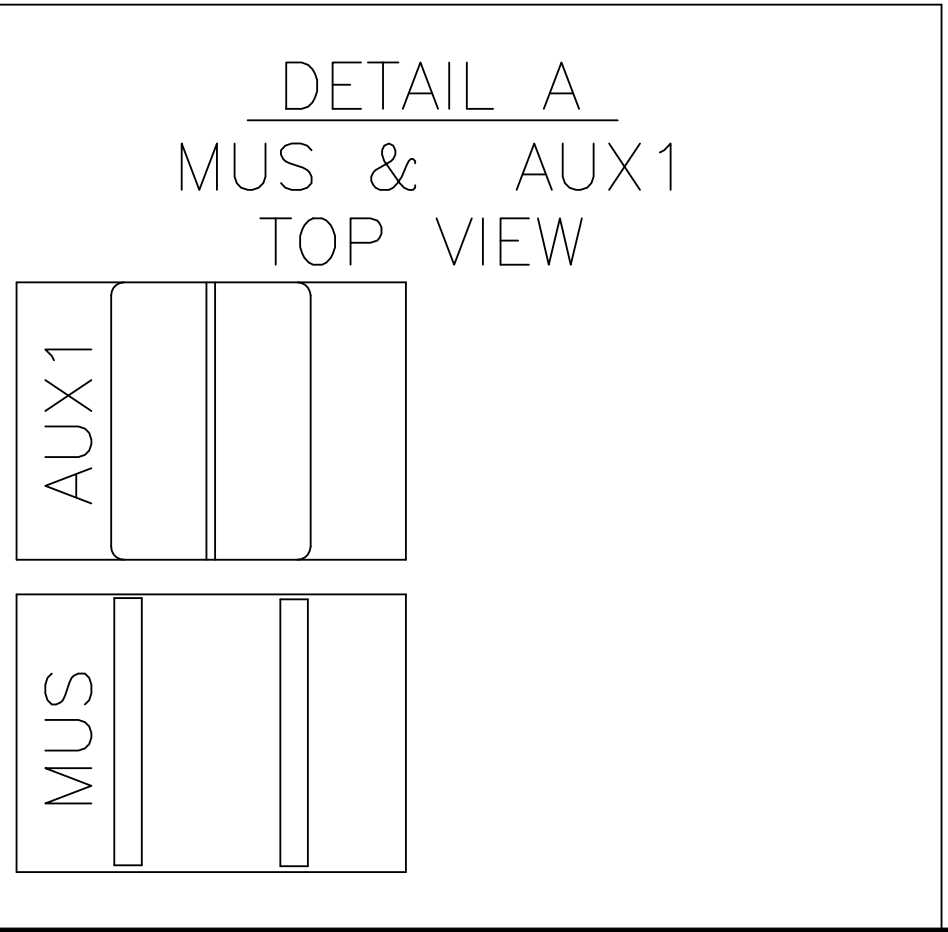
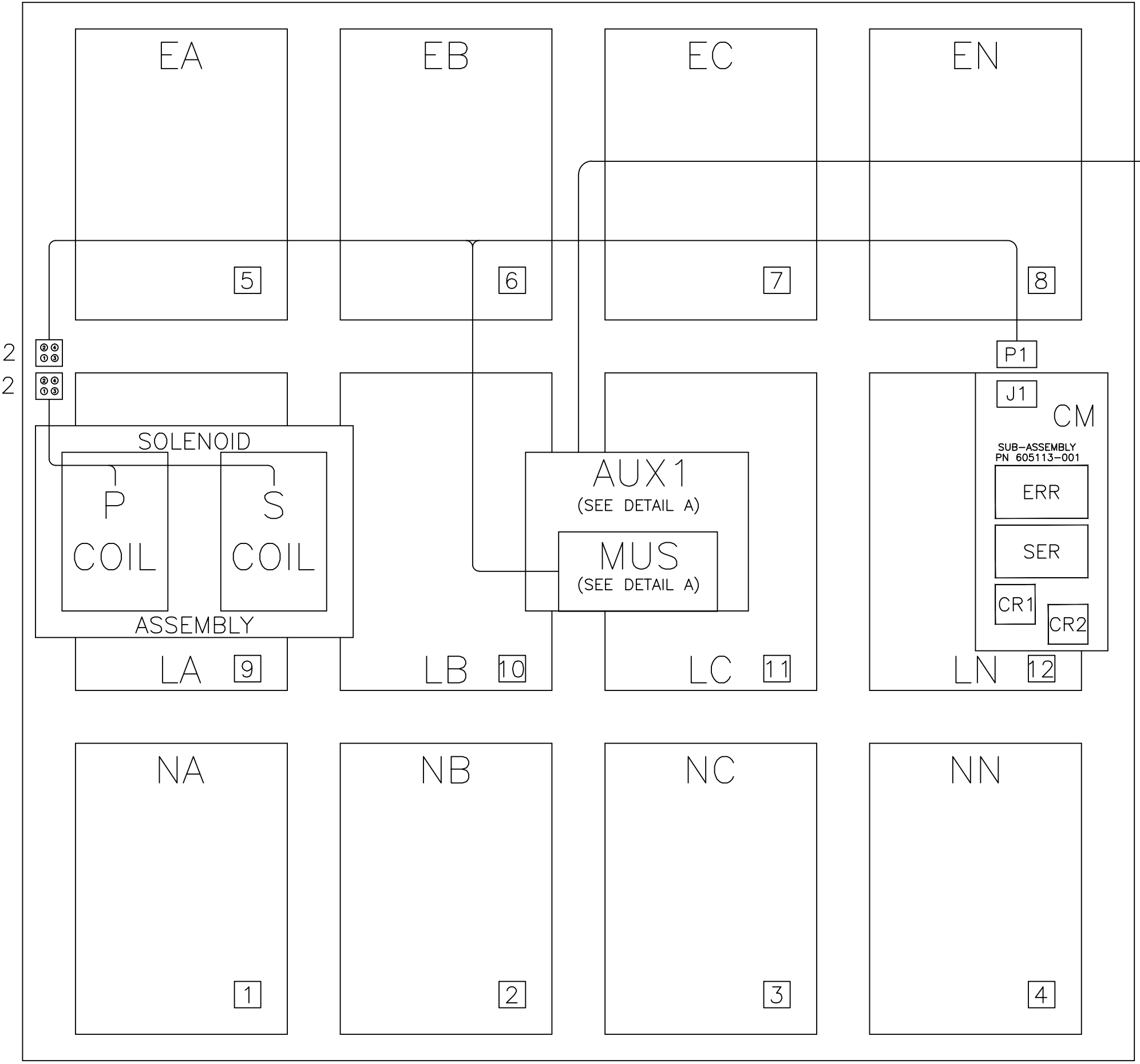
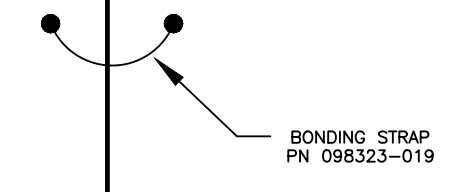
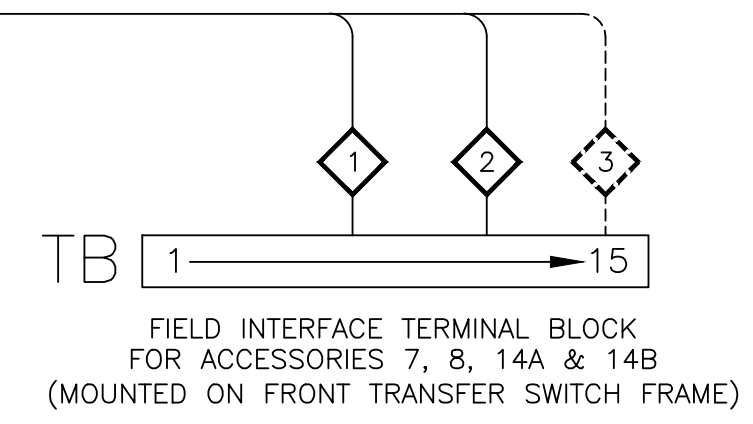
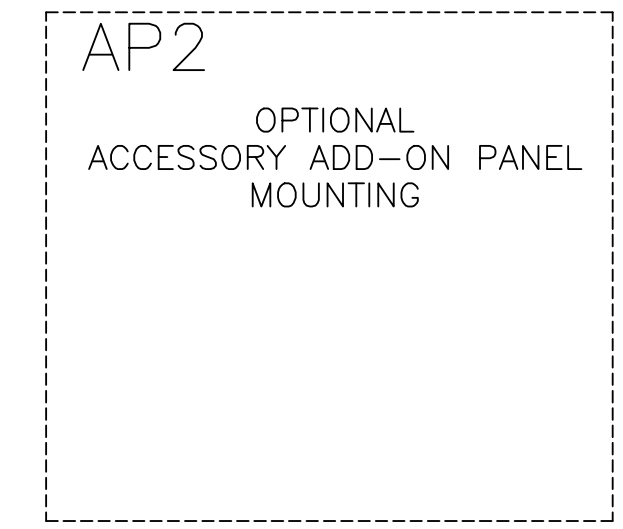
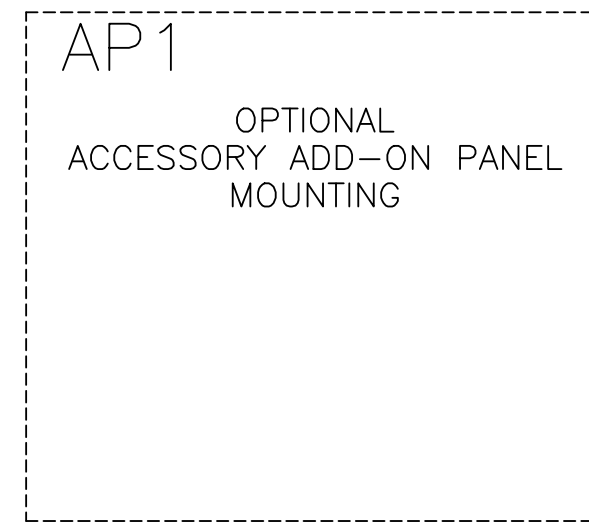
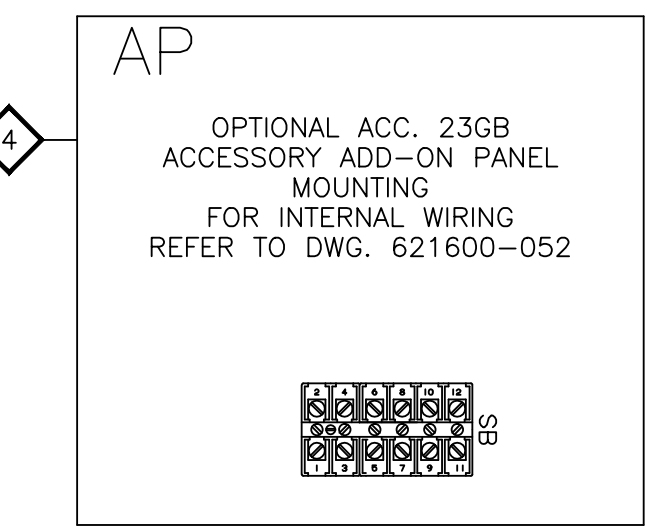
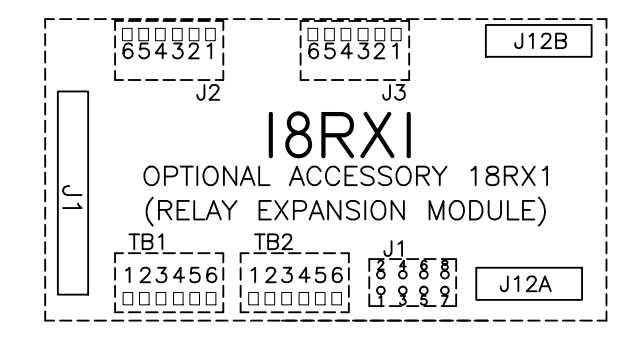
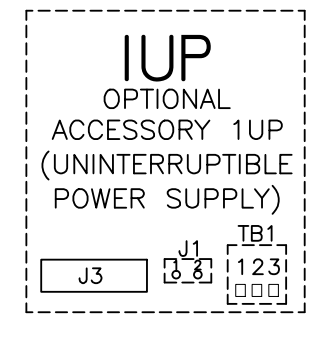
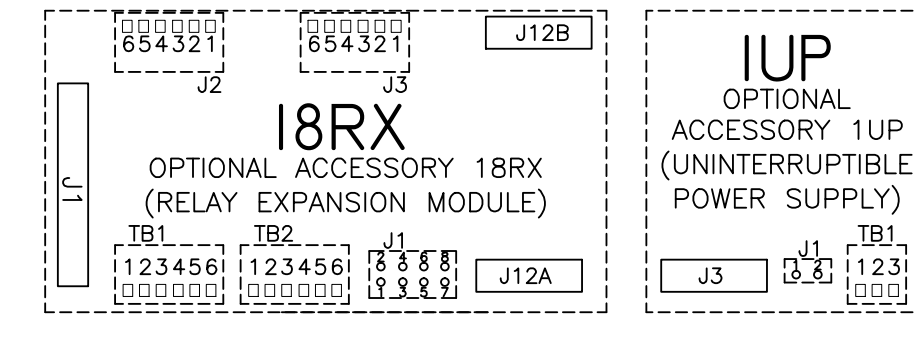
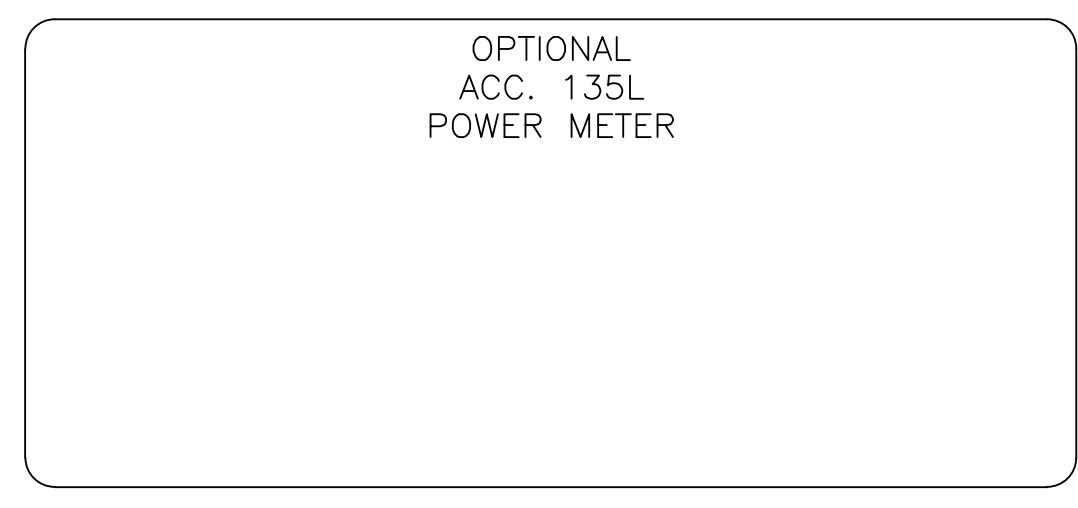
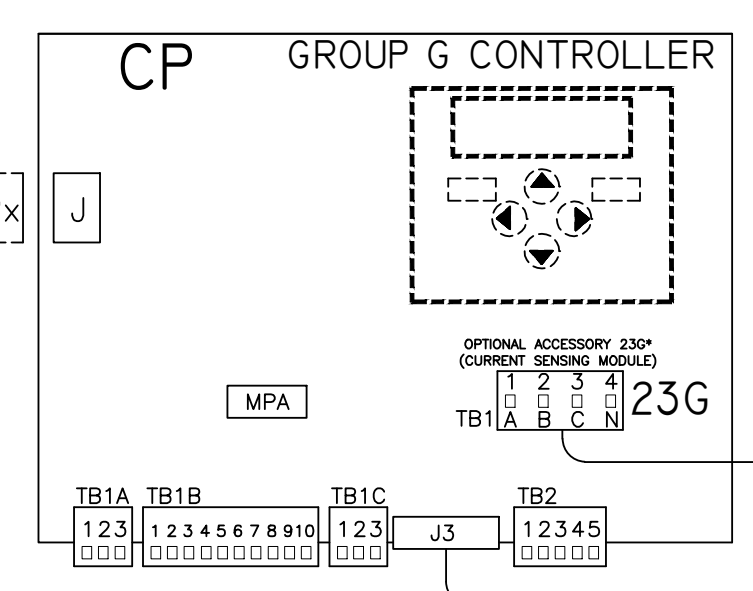

PROJECT NAME:		245072	BK	BK	10/28/13
WIRING DIAGRAM		ISSUE	BY	APP.	DATE
300 SERIES (G3A/NTS) 3PH 1000-3000 AMPS		REV. TO SHEET	ECN NO.	BY	APP.
"G" FRAME, GROUP G CONTROLS		COMPUTER GENERATED DRAWING		THIRD ANGLE PROJECTION	
DRAWN BY	DJB	DATE	10/28/13	ASSEM. REF. NO.	
CHECKED	BK	DATE	10/28/13	SCALE	NONE
PROJECT APPROVAL	BK	DATE	10/28/13	SIZE	DS
FINAL APPROVAL		DATE		DWG. NO.	1001662
ASCO Power Technologies, L.P.		DRAWING REV.	245072	SHEET	5 OF 7
FLORHAM PARK, NEW JERSEY 07932 U.S.A.					

8 7 6 5 4 3 2 1

PHYSICAL DIAGRAM (CONTINUED)

FRONT CONNECTED SWITCH  
1000 - 2000 AMP. TS TOP VIEW

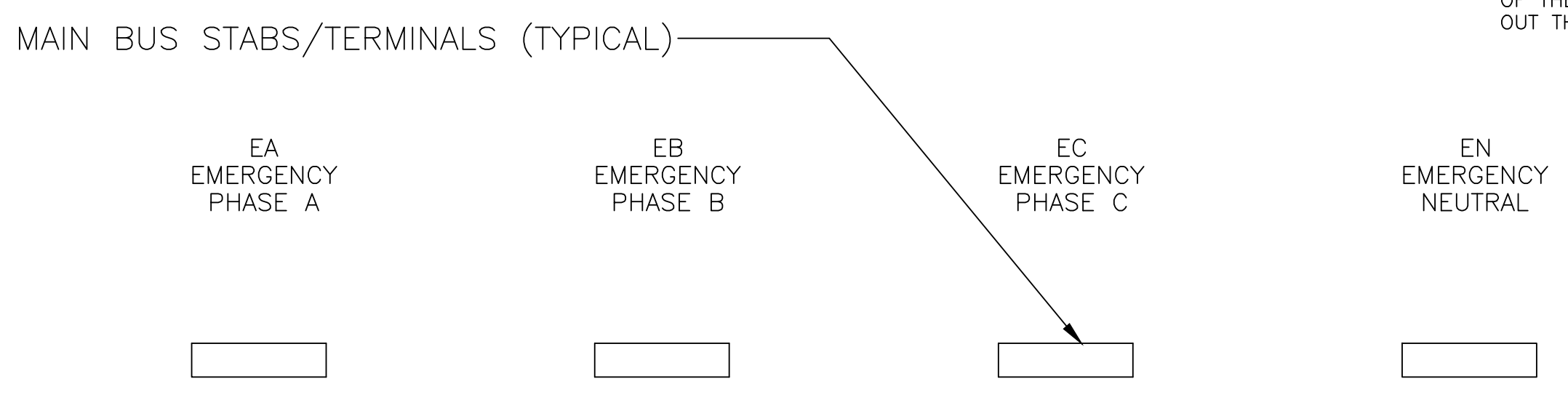
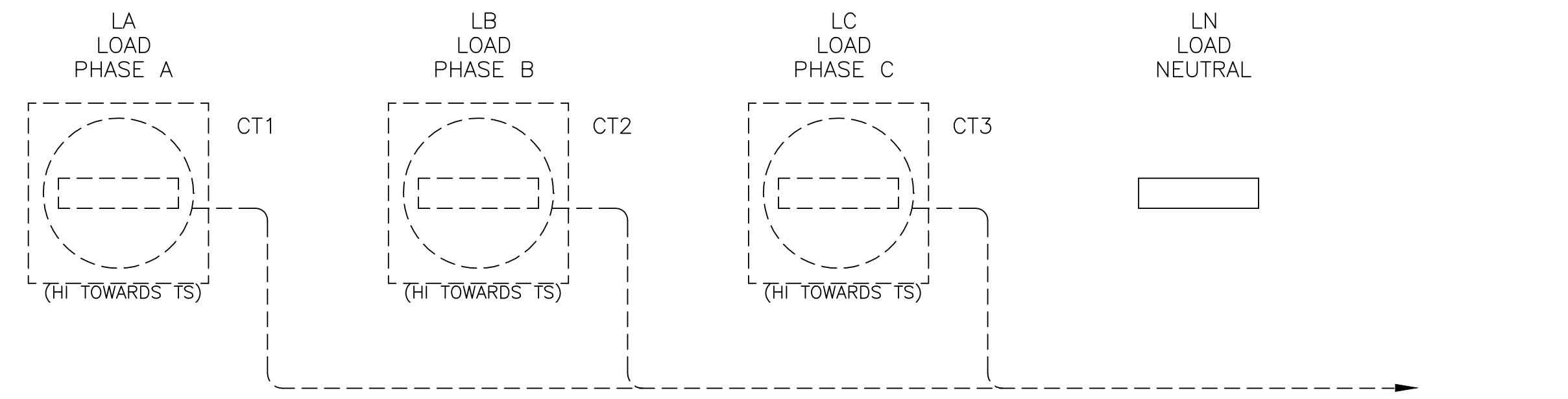

OPTIONAL ACCESSORY 23GB (LOAD CURRENT METERING)

BOTTOM VIEW

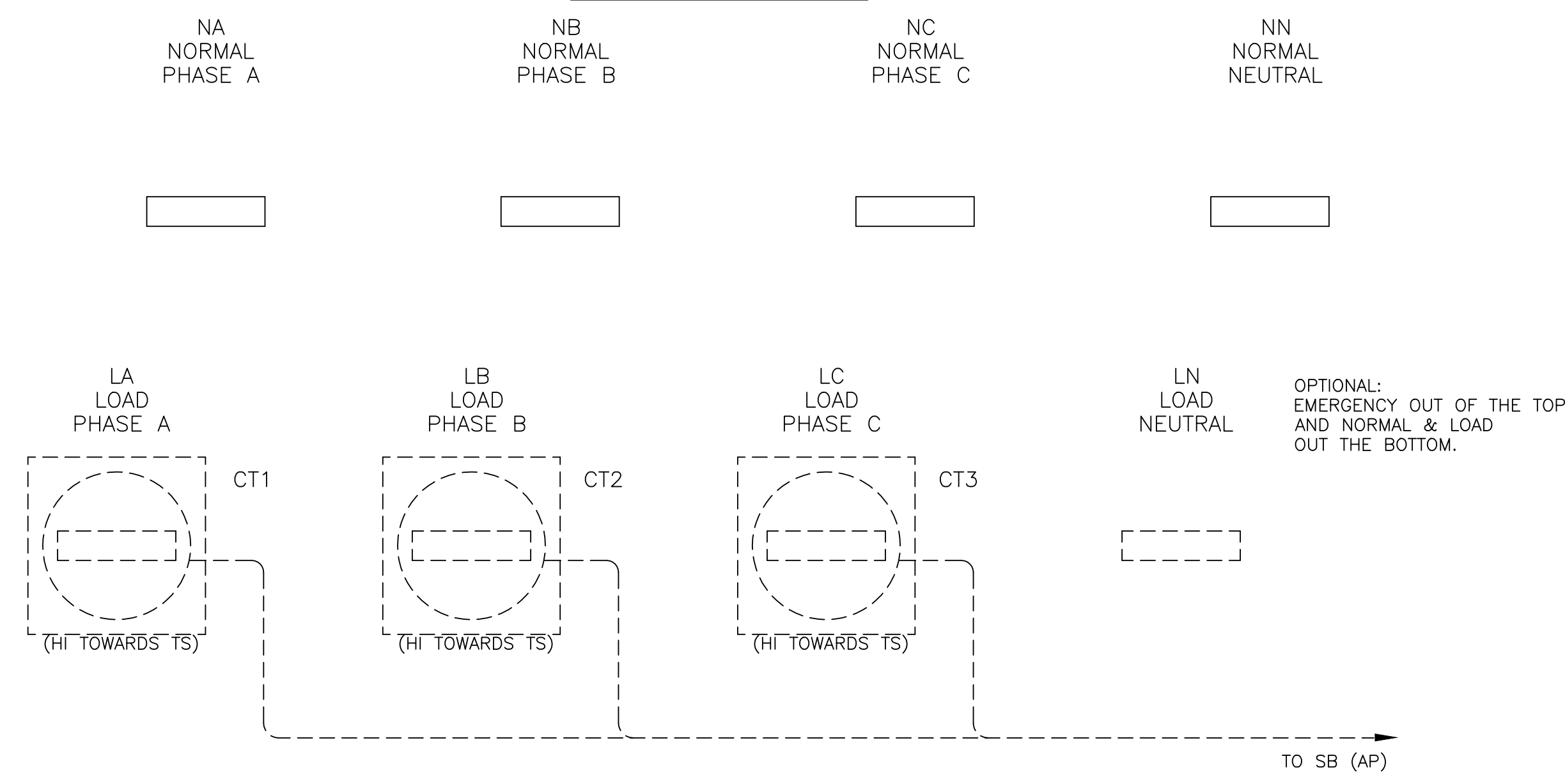

PROJECT NAME:		REV. TO SHEET	ECN NO.	BY	APP.	DATE
WIRING DIAGRAM		245072	BK	BK		10/28/13
300 SERIES (G3A/NTS) 3PH 1000-3000 AMPS "G" FRAME, GROUP G CONTROLS		COMPUTER GENERATED DRAWING				
DRAWN BY	DATE	MANUFACTURING TOLERANCES TO BE IN ACCORDANCE WITH ASCO PROCEDURE MP-1-003. FOR PLASTIC PARTS SEE MP-1-055.		ASSEM. REF. NO.		
CHECKED	DATE	PROPERTY OF ASCO POWER TECHNOLOGIES. USE PERMITTED FOR OUR WORK ONLY. ALL RIGHTS OF DESIGN OR INVENTION ARE RESERVED.		SCALE NONE SIZE DS		
PROJECT APPROVAL	DATE	ASCO® ASCO POWER TECHNOLOGIES, L.P. FLORHAM PARK, NEW JERSEY 07932 U.S.A.		DWG. NO. 1001662		
FINAL APPROVAL		DRAWING REV.		EZN NO. 245072 SHEET 6 OF 7		

8 7 6 5 4 3 2 1

WIRE RUN LISTING

1 ← HARNESS LOCATOR		BOX CHECKED IF HARNESS IS MODIFIED	
WIRE No.	HARNESS 605454 (P,P1,P2,J3) MAIN TS	CLR	AWG
1	P-2,TS-1		16
2	P-3,P1-14		
3	P-4,TS-3		
4	P-5,TS-5		
5	P-6,TS-7		
4	P-7,TS-5		
6	P-8,TS(AUX1)-24		
6	TS(AUX1)-24,J3-1		
7	P-9,TS(AUX1)-25		
7	TS(AUX1)-25,J3-2		
8	P-10,TS(AUX1)-21		
9	P-11,TS-2		
10	P-12,TS-1		
11	P-13,TS(AUX1)-22		
12	P-14,TS(AUX1)-23		
13	P-16,P1-16		
14	P-17,J3-3		
15	P-18,TS-6		
16	P-19,TS-9		
17	P-20,TS-10		
18	P-21,TS-11		
19	P-22,TS-4		
20	P-23,TS-8		
21	P-24,TS-12		
22	P1-5,TS(MUS)-17		
22	TS(MUS)-17,TS(MUS)-15		
23	P1-6,TS(MUS)-19		
23	TS(MUS)-19,TS(MUS)-13		
24	P1-9,P2-4		
25	P1-10,P2-1		
26	P1-11,P2-2		
27	P1-12,P2-3		
28	P1-13,TS(MUS)-16		
28	TS(MUS)-16,TS(MUS)-14		
29	P1-15,TS(MUS)-20		
29	TS(MUS)-20,TS(MUS)-18		
11	P1-17,TS-1		
4	P1-18,TS-5		
3	P1-19,TS-3		
5	P1-20,TS-7		
30	P1-21,P1-23		
REMOVE WIRES			
6	TS(AUX1)-24,J3-1		
7	TS(AUX1)-25,J3-2		
14	P-17,J3-3		
ADD WIRES			
6	TS(AUX1)-24,TB-1		
7	TS(AUX1)-25,TB-2		
200	P-1		
14	P-17,TB-3		
222	P-15		

2 ← HARNESS LOCATOR		BOX CHECKED IF HARNESS IS MODIFIED	
WIRE No.	TS STD. AUX. CONTACTS	CLR	AWG
40	TB-4,TS(AUX1)-27		16
41	TB-5,TS(AUX1)-28		
42	TB-6,TS(AUX1)-29		
43	TB-7,TS(AUX1)-30		
44	TB-8,TS(AUX1)-31		
45	TB-9,TS(AUX1)-32		

3 ← HARNESS LOCATOR		BOX CHECKED IF HARNESS IS MODIFIED	
WIRE No.	OPTIONAL AUX. CONTACTS	CLR	AWG
46	TB-10,TS(AUX1)-33		16
47	TB-11,TS(AUX1)-34		
48	TB-12,TS(AUX1)-35		
49	TB-13,TS(AUX1)-36		
50	TB-14,TS(AUX1)-38		
51	TB-15,TS(AUX1)-37		

4 ← HARNESS LOCATOR		BOX CHECKED IF HARNESS IS MODIFIED	
WIRE No.	OPTIONAL ACCESSORY 23GB (CT*AP-SB,CP(23G)-TB1)	CLR	AWG
230	CT1-X1,AP-SB-1		16
230	AP-SB-2,CP(23G)-TB1-1		
231	CT2-X1,AP-SB-3		
231	AP-SB-4,CP(23G)-TB1-2		
232	CT3-X1,AP-SB-5		
232	AP-SB-6,CP(23G)-TB1-3		
233	CT1-X2,CT2-X2	GRN	
233	CT2-X2,CT3-X2	GRN	
233	CT3-X2,AP-SB-7	GRN	
233	AP-SB-7,EQUIP. GRD.	GRN	
233	AP-SB-8,CP(23G)-TB1-4	GRN	

5 ← HARNESS LOCATOR		BOX CHECKED IF HARNESS IS MODIFIED	
WIRE No.	HARNESS 309320-005 OPTIONAL 8 IN. EXTENSION HARNESS	CLR	AWG
200	Jx-1,Px-1		16
1	Jx-2,Px-2		
2	Jx-3,Px-3		
3	Jx-4,Px-4		
4	Jx-5,Px-5		
5	Jx-6,Px-6		
4	Jx-7,Px-7		
6	Jx-8,Px-8		
7	Jx-9,Px-9		
8	Jx-10,Px-10		
9	Jx-11,Px-11		
10	Jx-12,Px-12		
11	Jx-13,Px-13		
12	Jx-14,Px-14		
222	Jx-15,Px-15		
13	Jx-16,Px-16		
14	Jx-17,Px-17		
15	Jx-18,Px-18		
16	Jx-19,Px-19		
17	Jx-20,Px-20		
18	Jx-21,Px-21		
19	Jx-22,Px-22		
20	Jx-23,Px-23		
21	Jx-24,Px-24		

WIRE No.	ADDITIONAL WIRING	CLR	AWG
			16

PROJECT NAME:		REV. TO SHEET	ECN NO.	BY	APP.	DATE
WIRING		245072 BK BK 10/28/13		ISSUE		
300 SERIES (G3A/NTS) 3PH 1000-3000 AMPS		DIAGRAM		THIRD ANGLE PROJECTION		
"G" FRAME, GROUP G CONTROLS		COMPUTER GENERATED DRAWING		SCALE NONE SIZE DS		
DRAWN BY	DJB	DATE	10/28/13	PROPERTY OF ASCO POWER TECHNOLOGIES. USE PERMITTED FOR OUR WORK ONLY. ALL RIGHTS OF DESIGN OR INVENTION ARE RESERVED.	DWG. NO. 1001662	
CHECKED	BK	DATE	10/28/13	ASCO® ASCO POWER TECHNOLOGIES, L.P. FLOHAM PARK, NEW JERSEY 07932 U.S.A.	DRAWING REV. ECN NO. 245072 SHEET 7 OF 7	
FINAL APPROVAL						