

SINGLE PHASE WIRING FOR ASCO® 300 SERIES TRANSFER SWITCHES (E3ATS/E3NTS) 260 & 400 AMPERES WITH GROUP G CONTROLS

GENERAL INFORMATION

THIS WIRING APPLIES TO 300 SERIES TRANSFER SWITCHES THAT UTILIZE THE "E" FRAME POWER TRANSFER SWITCH RATED 260 & 400 AMPERES.

THE GROUP G CONTROLLER PROVIDES EITHER AUTOMATIC (E3ATS) OR NON-AUTOMATIC [MANUAL] (E3NTS) OPERATION BASED ON ITS FACTORY SETTING ACCORDING TO THE CUSTOMER ORDER REQUIREMENTS.

THE TYPE OF TRANSFER SWITCH PROVIDED CAN BE DETERMINED FROM THE PRODUCT IDENTIFICATION MARKINGS LOCATED ON BOTH THE POWER TRANSFER SWITCH AND THE COVER OF THE GROUP G CONTROLLER.

ALL OPERATIONAL SETTINGS AND SEQUENCES OF THE GROUP G CONTROLLER AND ITS RELATED OPTIONAL ACCESSORIES (1UP, 18RX, 23G) ARE PROVIDED IN THE USER'S GUIDE, ASCO GROUP G CONTROLLER FOR AUTOMATIC & NON-AUTOMATIC TRANSFER SWITCHES, PART NUMBER 381333-400.

INFORMATION FOR INSTALLATION AND TESTING OF THE TRANSFER SWITCH IS PROVIDED IN THE INSTALLATION MANUAL, ASCO 3ATS & 3NTS, E-DESIGN 260 & 400 A TRANSFER SWITCHES, PART NUMBER 381333-403.

ENGINE CONTROL CONTACTS

FEATURE 7 & FEATURE 8:
ONE SET OF FORM C CONTACTS "NR" (FEAT. 7 N/C, FEAT. 8 N/O) THAT CHANGE POSITION ON EXPIRATION OF THE FEATURE 1C, OVERRIDE MOMENTARY NORMAL SOURCE OUTAGES TIME DELAY, AND RESET ON EXPIRATION OF THE FEATURE 2E ENGINE COOLDOWN TIME DELAY.
AN AUXILIARY CONTACT THAT IS CLOSED WHEN THE TRANSFER SWITCH IS CONNECTED TO THE EMERGENCY SOURCE, IS CONNECTED ACROSS THE N/C CONTACT (FEATURE 7).

AN ADDITIONAL SET OF ENGINE STARTING CONTACTS ARE AVAILABLE ON THE GROUP G CONTROLLER WHEN THE FEATURE SETTING OF THE CONTROLLER OUTPUT CONTACTS "OP1" IS SET TO OPERATE AS "NR2".

ADDITIONAL OPTIONAL ENGINE STARTING CONTACTS "NR2" ARE AVAILABLE WHEN OPTIONAL ACCESSORY 18RX (RELAY EXPANSION MODULE) IS INCLUDED IN THE TRANSFER SWITCH ASSEMBLY. OUTPUT CONTACTS "OP2" AND/OR "OP3" PROVIDE THE ENGINE STARTING FUNCTION WHEN THE FEATURE SETTING OF EACH IS SET TO OPERATE AS "NR2".

CONTACTS ARE RATED 5 AMPS RESISTIVE AT 30 VDC MAXIMUM, 100 mA AT 5 VDC MINIMUM.

REFER TO USER'S GUIDE, ASCO GROUP G CONTROLLER FOR AUTOMATIC & NON-AUTOMATIC TRANSFER SWITCHES, PART NUMBER 381333-400 FOR SETTING INFORMATION.

LOAD DISCONNECT FEATURE

FEATURE 31: INCLUDES SUB-FEATURES 31F, 31G, 31M, 31N
A SET OF FORM C CONTACTS ARE PROVIDED ON THE GROUP G CONTROLLER AS "OP1". WHEN THE FEATURE SETTING OF "OP1" IS SET TO OPERATE THE CONTACTS AS "FEATURE 31", THE TIME DELAY SETTINGS OF THE SUB-FEATURES ARE AVAILABLE.

"OP1" CAN BE SET TO OPERATE TO PROVIDE THE FOLLOWING FUNCTIONS USING THE TIME DELAY SETTINGS ASSOCIATED WITH EACH SUB-FEATURE:

31F - NORMAL TO EMERGENCY PRE-TRANSFER SIGNAL
31G - EMERGENCY TO NORMAL PRE-TRANSFER SIGNAL
31M - NORMAL TO EMERGENCY POST-TRANSFER SIGNAL
31N - EMERGENCY TO NORMAL POST-TRANSFER SIGNAL

THE "OP1" OUTPUT CONTACTS CHANGE POSITION FOLLOWING EACH OF THE ABOVE TIME DELAYS.

ADDITIONAL LOAD DISCONNECT CONTACTS, "FEATURE 31" ARE AVAILABLE WHEN OPTIONAL ACCESSORY 18RX (RELAY EXPANSION MODULE) IS INCLUDED IN THE TRANSFER SWITCH ASSEMBLY. OUTPUT CONTACTS "OP2" AND/OR "OP3" WILL PROVIDE LOAD DISCONNECT FUNCTIONS WHEN THE FEATURE SETTING OF EACH IS SET TO OPERATE AS "FEATURE 31".

ALL OUTPUT CONTACTS ("OP1", "OP2", "OP3") SET TO OPERATE AS "FEATURE 31", SHARE THE COMMON TIME DELAY SETTINGS OF SUB-FEATURES 31F, 31G, 31M, AND 31N.

CONTACTS ARE RATED 5 AMPS RESISTIVE AT 30 VDC MAXIMUM, 100 mA AT 5 VDC MINIMUM.

REFER TO USER'S GUIDE, ASCO GROUP G CONTROLLER FOR AUTOMATIC & NON-AUTOMATIC TRANSFER SWITCHES, PART NUMBER 381333-400 FOR SETTING INFORMATION.

INPHASE TRANSFER FEATURE FOR LOAD TRANSFER

INPHASE TRANSFER CONTROL INITIATES AN INPHASE TRANSFER OF LOADS BETWEEN LIVE SOURCES. THIS IS USED TO PREVENT NUISANCE TRIPPING OF DISTRIBUTION CIRCUIT BREAKERS AND POSSIBLE DAMAGE TO MECHANICAL LOADS ASSOCIATED WITH OUT OF PHASE TRANSFER.

REFER TO USER'S GUIDE, ASCO GROUP G CONTROLLER FOR AUTOMATIC & NON-AUTOMATIC TRANSFER SWITCHES, PART NUMBER 381333-400 FOR SETTING INFORMATION.

SOURCE AVAILABILITY SIGNALS

SIGNALS INDICATING THE AVAILABILITY OF THE NORMAL & EMERGENCY SOURCES IS PROVIDED WHEN OPTIONAL ACCESSORY 18RX (RELAY EXPANSION MODULE) IS INCLUDED IN THE TRANSFER SWITCH ASSEMBLY. OUTPUT CONTACTS "RL5" (EMERGENCY SOURCE AVAILABLE) AND "RL6" (NORMAL SOURCE AVAILABLE) CHANGE POSITION WHEN THE SOURCE IS ACCEPTABLE.

CONTACTS ARE RATED 5 AMPS RESISTIVE AT 30 VDC MAXIMUM, 100 mA AT 5 VDC MINIMUM.

COMMON ALARM & NOT IN AUTO SIGNALING FEATURES

A SET OF FORM C CONTACTS IS PROVIDED ON THE GROUP G CONTROLLER AS "OP1". THE FEATURE SETTING OF "OP1" CAN BE SET TO OPERATE THE CONTACTS AS A "NOT IN AUTO" SIGNAL.

WHEN "OP1" IS SET FOR "NOT IN AUTO", THE OUTPUT CONTACTS CHANGE POSITION WHEN THE TRANSFER IS BEING INHIBITED FROM TRANSFERRING TO THE EMERGENCY SOURCE (FEATURE 34B) OR THE TRANSFER SWITCH HAS BEEN SET FOR NON-AUTOMATIC (MANUAL) OPERATION.

WHEN OPTIONAL ACCESSORY 11BE "SOFTWARE BUNDLE" IS PART OF THE TRANSFER SWITCH ASSEMBLY, "OP1" MAY ALTERNATIVELY SET FOR A "COMMON ALARM" SIGNAL. THE OUTPUT CONTACTS CHANGE POSITION WHEN A "COMMON ALARM" IS NOT PRESENT AND RESET WHEN A "COMMON ALARM" CONDITION IS PRESENT. THE "COMMON ALARM" SIGNAL CONDITIONS ARE SELECTABLE.

ADDITIONAL "COMMON ALARM" AND "NOT IN AUTO" CONTACTS ARE AVAILABLE WHEN OPTIONAL ACCESSORY 18RX (RELAY EXPANSION MODULE) IS INCLUDED IN THE TRANSFER SWITCH ASSEMBLY. OUTPUT CONTACTS "OP2 AND/OR "OP3" WILL PROVIDE SIGNAL FUNCTIONS WHEN THE FEATURE SETTING OF EACH IS SET TO OPERATE AS "COMMON ALARM" OR "NOT IN AUTO".

CONTACTS ARE RATED 5 AMPS RESISTIVE AT 30 VDC MAXIMUM, 100 mA AT 5 VDC MINIMUM.

REFER TO USER'S GUIDE, ASCO GROUP G CONTROLLER FOR AUTOMATIC & NON-AUTOMATIC TRANSFER SWITCHES, PART NUMBER 381333-400 FOR SETTING INFORMATION.

EXTERNAL POWER SUPPLY COMPATIBILITY

USE OF AN EXTERNAL POWER SUPPLY IS USEFUL WHEN REQUIRED TO EXTEND THE FOLLOWING CONTROLLER TIME DELAYS BEYOND 6 SECONDS:

FEATURE 1C - OVERRIDE MOMENTARY NORMAL SOURCE OUTAGES
FEATURE 1F - OVERRIDE MOMENTARY EMERGENCY SOURCE OUTAGES

AN EXTERNAL POWER SUPPLY IS ALSO USEFUL WHEN THE TRANSFER SWITCH IS USED WITH COMMUNICATIONS FEATURES BY ENABLING THE CONTROLLER TO CONTINUE COMMUNICATING.

AN EXTERNAL POWER SOURCE MAY BE PROVIDED TO THE CONTROLLER, UNTIL THE NORMAL SOURCE OR EMERGENCY SOURCE IS AVAILABLE, BY USE OF:

- AN EXTERNAL 24 VDC POWER SUPPLY WITH ACCESSORY 18RX (RELAY EXPANSION MODULE)
- OR
- OPTIONAL ACCESSORY 1UP (UNINTERRUPTIBLE POWER SUPPLY MODULE)

EXTERNAL 24 VDC POWER SUPPLY "1G":
AN EXTERNAL 24 VDC POWER SUPPLY MAY BE USED TO POWER THE CONTROLLER WHEN ACCESSORY 18RX (RELAY EXPANSION MODULE) IS INCLUDED IN THE TRANSFER SWITCH ASSEMBLY. OUTPUT CONTACTS "OP2" WILL PROVIDE EXTERNAL 24 VDC POWER SUPPLY FUNCTIONALITY WHEN ITS FEATURE SETTING IS SET TO OPERATE AS "1G". ADDITIONALLY, JUMPERS MUST BE RECONFIGURED ON ACCESSORY 18RX (RELAY EXPANSION MODULE) TO ENABLE THIS FUNCTION AS FOLLOWS:

REMOVE JUMPERS "J1" 1-2 & "J1" 3-4
CONNECT JUMPERS "J1" 5-7 & "J1" 6-8

THE OUTPUT CONTACTS CHANGE POSITION WHEN EITHER THE NORMAL SOURCE OR EMERGENCY SOURCE IS AVAILABLE AND RESET WHEN NEITHER SOURCE IS AVAILABLE. THE "OP2" N/C CONTACT SWITCHES CUSTOMER PROVIDED +24 VDC FROM THE EXTERNAL POWER SUPPLY TO THE CONTROLLER.

REFER TO USER'S GUIDE, ASCO GROUP G CONTROLLER FOR AUTOMATIC & NON-AUTOMATIC TRANSFER SWITCHES, PART NUMBER 381333-400 FOR SETTING INFORMATION.

ACCESSORY 1UP (UNINTERRUPTIBLE POWER SUPPLY):
WHEN OPTIONAL ACCESSORY 1UP IS INCLUDED IN THE TRANSFER SWITCH ASSEMBLY, THE CONTROLLER IS PROVIDED WITH LIMITED RESERVE POWER (APPROXIMATELY 3 MINUTES).

LOAD CURRENT METERING

WHEN OPTIONAL ACCESSORY 23GA IS PART OF THE TRANSFER SWITCH ASSEMBLY, PHASE CURRENT MEASUREMENTS ARE AVAILABLE FOR DISPLAY ON THE GROUP G CONTROLLER.

REFER TO USER'S GUIDE, ASCO GROUP G CONTROLLER FOR AUTOMATIC & NON-AUTOMATIC TRANSFER SWITCHES, PART NUMBER 381333-400 FOR INFORMATION ON USE.

FOUR-FUNCTION SOFTWARE BUNDLE

WHEN OPTIONAL ACCESSORY 11BE IS PART OF THE TRANSFER SWITCH ASSEMBLY, A FOUR-FUNCTION SOFTWARE BUNDLE IS AVAILABLE TO PERFORM THE FOLLOWING FUNCTIONS:

- SERIAL COMMUNICATIONS (RS-485)
- PROGRAMMABLE ENGINE EXERCISER
- EVENT LOG
- COMMON ALARM SIGNAL CAPABILITY ON GROUP G CONTROLLER "OP1" OUTPUT.

REFER TO USER'S GUIDE, ASCO GROUP G CONTROLLER FOR AUTOMATIC & NON-AUTOMATIC TRANSFER SWITCHES, PART NUMBER 381333-400 FOR INFORMATION ON THESE FUNCTIONS.

NON-AUTOMATIC (MANUAL) OPERATION

TRANSFER SWITCH ASSEMBLIES FACTORY SET FOR NON-AUTOMATIC OPERATION PROVIDE USER INITIATED, ELECTRICAL OPERATION OF THE TRANSFER SWITCH TO EITHER AVAILABLE SOURCE. THE TRANSFER SWITCH ASSEMBLY IS PHYSICALLY IDENTICAL TO THAT OF THE AUTOMATIC TYPE.

WHEN THE TRANSFER SWITCH IS SET FOR NON-AUTOMATIC OPERATION, A CUSTOMER PROVIDED SELECTOR SWITCH MAY BE USED TO OPERATE IT FROM A REMOTE LOCATION.

REMOTE CONTROL FEATURES

THE FOLLOWING CONTROL PANEL INPUTS PROVIDE REMOTE CONTROL FUNCTIONS FOR THE TRANSFER SWITCH. EACH FUNCTION CAN BE IMPLEMENTED BY THE CUSTOMER PROVIDING THE FORM OF CONTROL DESCRIBED. EACH CONTROL CONTACT MUST BE SUITABLE FOR A 5 VDC LOW ENERGY CIRCUIT.

EXTERNAL FEATURE 17: REMOTE TRANSFER TO EMERGENCY FEATURE (FOR AUTOMATIC TRANSFER TYPE ONLY) - REQUIRES A CUSTOMER SUPPLIED, NORMALLY CLOSED CONTACT. OPENING OF THE CONTACT CAUSES ENGINE START AND TRANSFER TO THE EMERGENCY SOURCE. RE-CLOSURE OF THE CONTACT ACTIVATES THE FEATURE 3A "RETRANSFER TO NORMAL (IF JUST TEST) TIME DELAY PRIOR TO RETRANSFER. IN THE EVENT THAT THE EMERGENCY SOURCE FAILS WHILE THE TRANSFER SWITCH IS CONNECTED TO EMERGENCY AND THE CUSTOMER SUPPLIED CONTACT IS OPEN, THE TRANSFER SWITCH WILL AUTOMATICALLY RETRANSFER TO THE NORMAL SOURCE.

EXTERNAL FEATURE 6B: REMOTE BYPASS OF RETRANSFER TO NORMAL TIME DELAY - REQUIRES A CUSTOMER SUPPLIED, NORMALLY CLOSED CONTACT. OPENING OF THE CONTACT BYPASSES FEATURE 3A RETRANSFER TO NORMAL DELAY IF ACTIVE.

REFER TO USER'S GUIDE, ASCO GROUP G CONTROLLER FOR AUTOMATIC & NON-AUTOMATIC TRANSFER SWITCHES, PART NUMBER 381333-400 FOR SETTING INFORMATION.

NOTES

1. SWITCH SHOWN DE-ENERGIZED CONNECTED TO NORMAL SOURCE.
2. DEVICE SYMBOLS AND DESIGNATIONS ARE IN ACCORDANCE WITH NEMA PUB. ICS 1, PART 1-101A.
3. ALL WIRING IS #16 AWG, TINNED, STRANDED COPPER UNLESS OTHERWISE INDICATED.
4. O INDICATES CUSTOMER CONNECTION POINTS.
5. ● INDICATES FACTORY CONNECTION POINTS.
6. CONNECTION POINTS THAT HAVE BOTH CUSTOMER CONNECTIONS AND FACTORY CONNECTIONS ARE SHOWN OPEN AS CUSTOMER CONNECTION POINTS.
7. THE TRANSFER UNIT IS MOUNTED ON THE BACK INSIDE SURFACE OF THE ENCLOSURE. THE CONTROL PANEL AND ANY OPTIONAL ACCESSORIES ARE MOUNTED ON THE INSIDE SURFACE OF THE DOOR.
8. AN OPERATOR'S MANUAL IS FURNISHED WITH EACH AUTOMATIC TRANSFER SWITCH. REFER TO THIS PUBLICATION PRIOR TO INSTALLATION AND OPERATION OF THE SWITCH.
9. GROUND STRAP ON CONTROL PANEL IS AFFIXED TO CHASSIS (ENCLOSURE) AT LOWER LEFT CONTROL PANEL MOUNTING STUD.

CATALOG NUMBER SUFFIXES										EXPLANATION OF CATALOG NUMBER CODES											
TS FRAME	CATALOG TYPE	NEUTRAL TYPE	PHASE POLES	AMPS	VOLT CODE	CONTROLLER	OPTIONAL ACCESSORY	ENCLOSURE CODE		NEUTRAL TYPE	VOLTAGE CODES	ENCLOSURE CODES									
										CODE	DESCRIPTION	CODE	NOMINAL VOLTAGE	CODE	TYPE	DESCRIPTION					
E	3ATS	A	2	260	C	G	X	C		A	SOLID SWITCHED OVERLAPPING	C	208	BLANK	1	OPEN TYPE (NO ENCLOSURE) GENERAL PURPOSE, INDOOR					
	3NTS	B		400	D			D		B		E	220	F	3R	OUTDOOR, RAINPROOF, SLEET & ICE RESISTANT					
		C			E			F		G		F	230	H	4X	INDOOR/OUTDOOR, WATERTIGHT & DUSTTIGHT					
					F			G		H		G	240	I	12	TYPE 4 PLUS CORROSION RESISTANCE (STAINLESS STEEL)					
					G			H		J		H	277			INDOOR, INDUSTRIAL ENVIRONMENTS, OILTIGHT & DUSTTIGHT					
					H			I		K		I	380			(SECURE ENCLOSURES)					
					J			J		L		J	400			OUTDOOR, RAINPROOF, SLEET & ICE RESISTANT					
					K			K		M		K	415			INDOOR/OUTDOOR, WATERTIGHT & DUSTTIGHT					
					L			L		N		L	440			TYPE 4 PLUS CORROSION RESISTANCE (STAINLESS STEEL)					
					M			M		P		M	460			INDOOR, INDUSTRIAL ENVIRONMENTS, OILTIGHT & DUSTTIGHT					
					N			N		Q		N	480								
					P			P		R		P	550								
					Q			Q				Q	575								
					R			R				R	600								
																INDOOR, INDUSTRIAL ENVIRONMENTS, OILTIGHT & DUSTTIGHT					

CATALOG NUMBER BASE CATALOG NUMBER
ASCO S.O. _____
 BY _____
 DATE _____

FORM REV - _____

PROJECT NAME: _____

WIRING DIAGRAM
 300 SERIES E3ATS/E3NTS, SINGLE PHASE 260 & 400 AMPS
 "E" FRAME, GROUP G CONTROLS

THIRD ANGLE PROJECTION

MANUFACTURING TOLERANCES TO BE IN ACCORDANCE WITH ASCO PROCEDURE MP-1-003. FOR PLASTIC PARTS SEE MP-1-055.

ASSEM. REF. NO. _____

PROPERTY OF ASCO POWER TECHNOLOGIES. USE PERMITTED FOR OUR WORK ONLY. ALL RIGHTS OF DESIGN OR INVENTION ARE RESERVED.

ASCO® ASCO Power Technologies, L.P.
 FLORENCE PARK, NEW JERSEY 07932 U.S.A.

SCALE NONE SIZE DS

DWG. NO. 978742

DRAWING REV. B ESN NO. 243244 SHEET 1 OF 6

FIELD CONNECTIONS

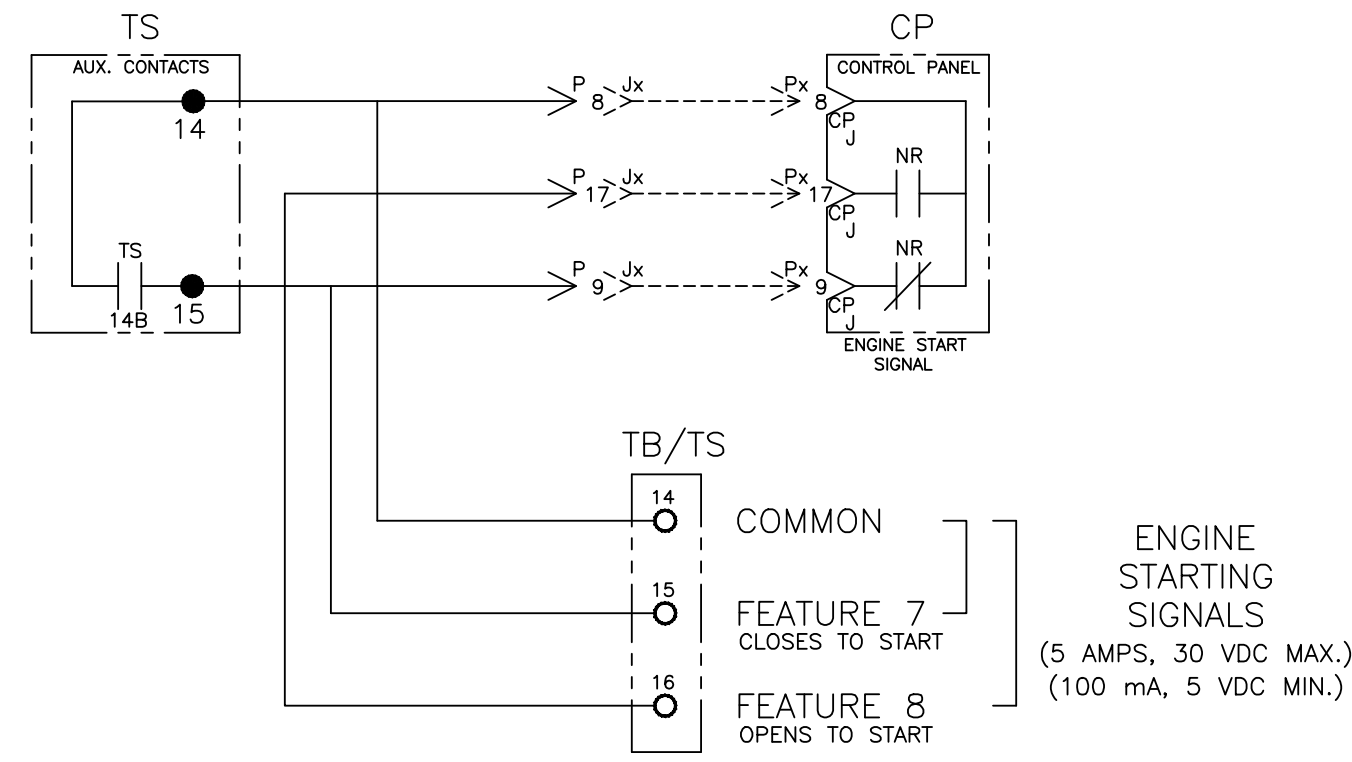

ENGINE STARTING SIGNALS
(5 AMPS, 30 VDC MAX.)
(100 mA, 5 VDC MIN.)

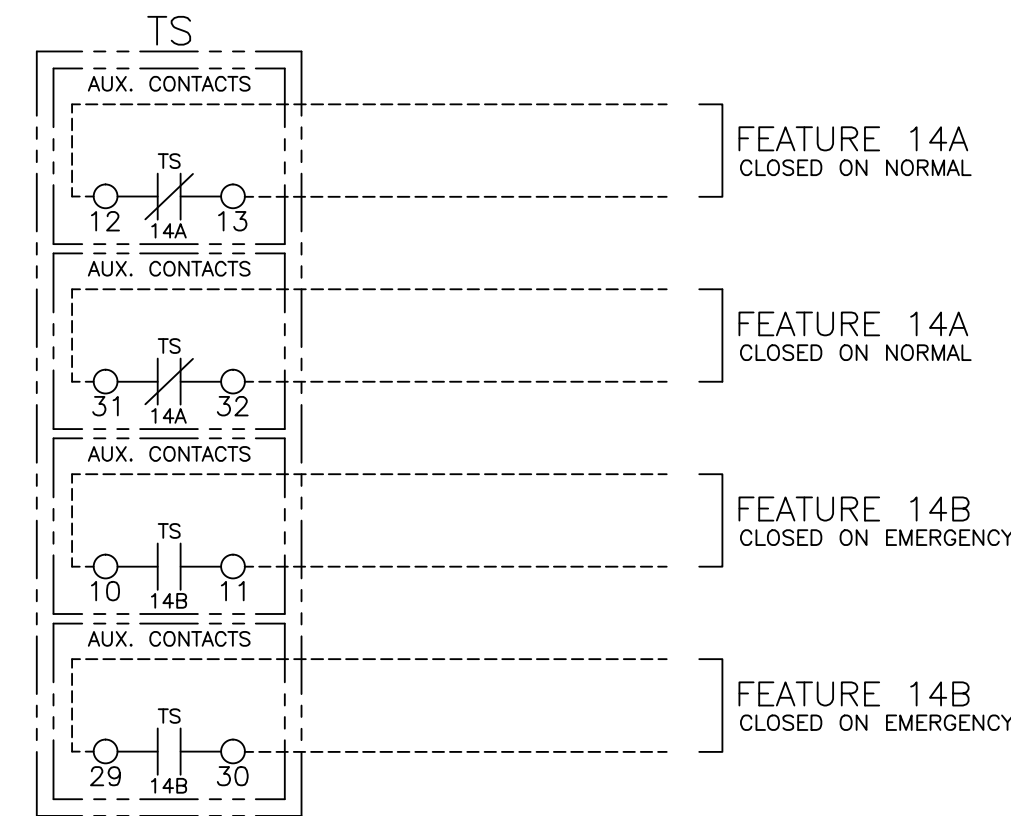

TS AUXILIARY CONTACTS FEATURE
14AA & 14BA
(10 AMPS, 32VDC)
(10 AMPS, 480VAC)
GENERAL PURPOSE

CONTROLLER OPTION RELAY "OP1" (STANDARD)

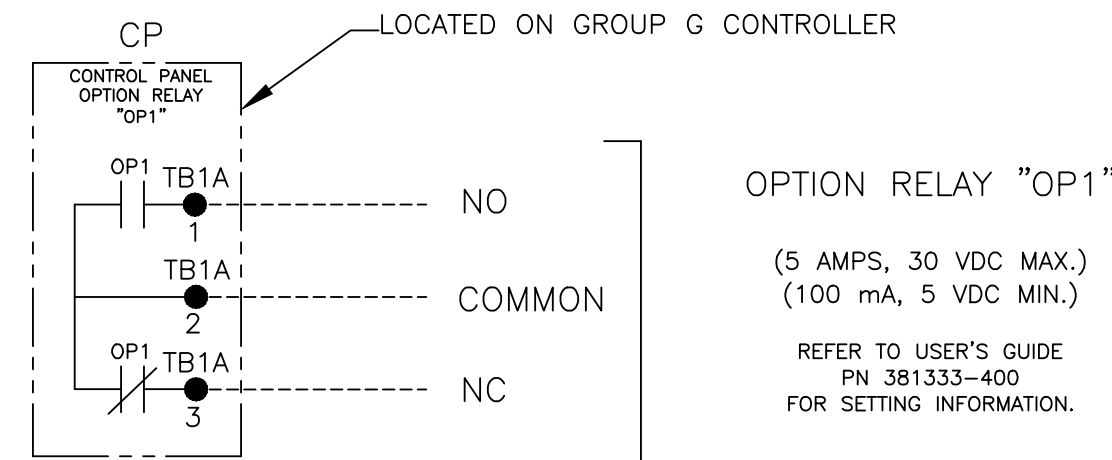

OPTION RELAY "OP1"
(5 AMPS, 30 VDC MAX.)
(100 mA, 5 VDC MIN.)
REFER TO USER'S GUIDE
PN 381333-400
FOR SETTING INFORMATION.

CONTROLLER REMOTE CONTROL FEATURES

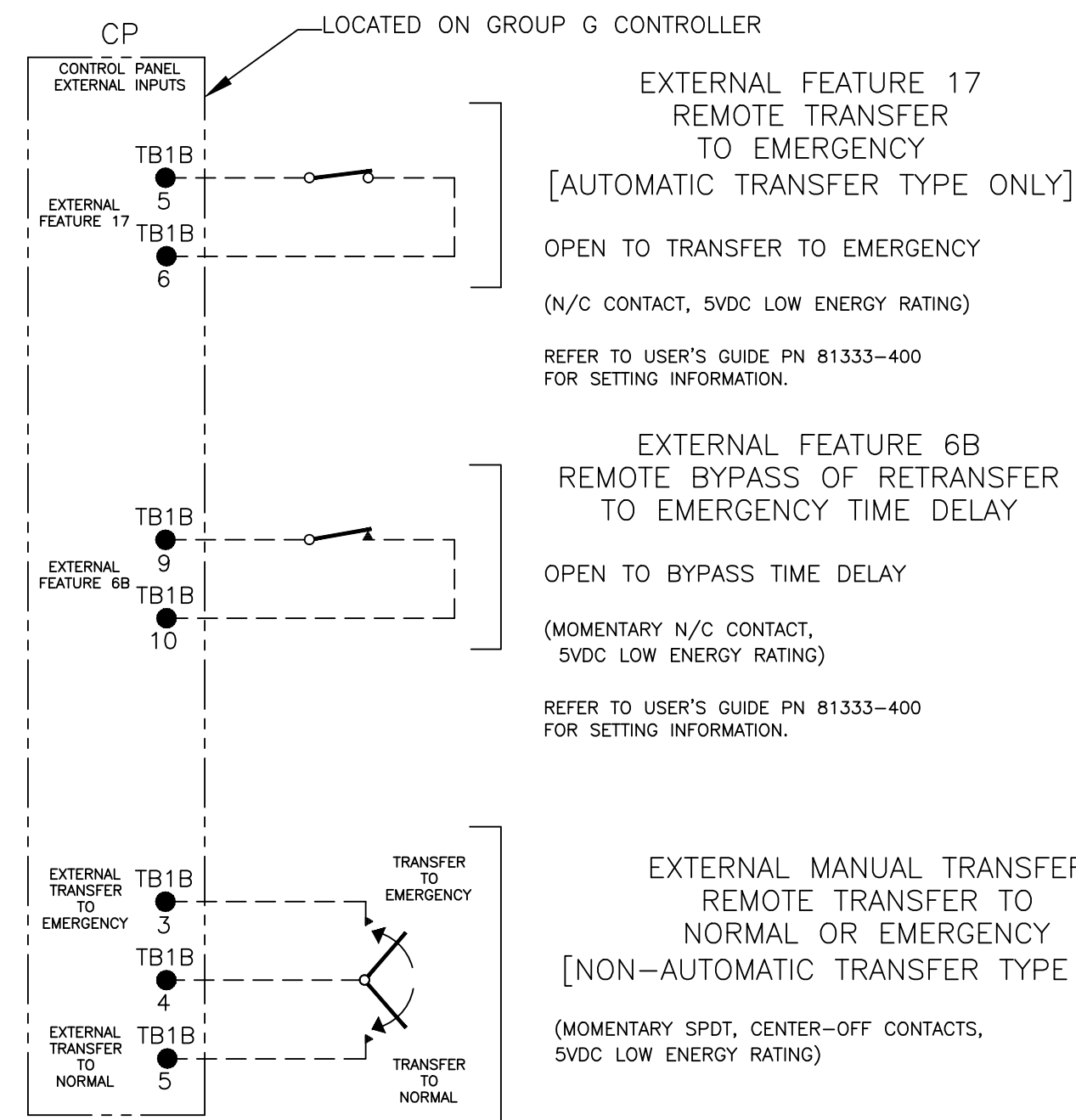

EXTERNAL FEATURE 17
REMOTE TRANSFER
TO EMERGENCY
[AUTOMATIC TRANSFER TYPE ONLY]
OPEN TO TRANSFER TO EMERGENCY
(N/C CONTACT, 5VDC LOW ENERGY RATING)
REFER TO USER'S GUIDE PN 81333-400
FOR SETTING INFORMATION.

EXTERNAL FEATURE 6B
REMOTE BYPASS OF RETRANSFER
TO EMERGENCY TIME DELAY
OPEN TO BYPASS TIME DELAY
(MOMENTARY N/C CONTACT,
5VDC LOW ENERGY RATING)
REFER TO USER'S GUIDE PN 81333-400
FOR SETTING INFORMATION.

EXTERNAL MANUAL TRANSFER
REMOTE TRANSFER TO
NORMAL OR EMERGENCY
[NON-AUTOMATIC TRANSFER TYPE ONLY]
(MOMENTARY SPDT, CENTER-OFF CONTACTS,
5VDC LOW ENERGY RATING)

OPTIONAL ACCESSORY 18RX (RELAY EXPANSION MODULE)

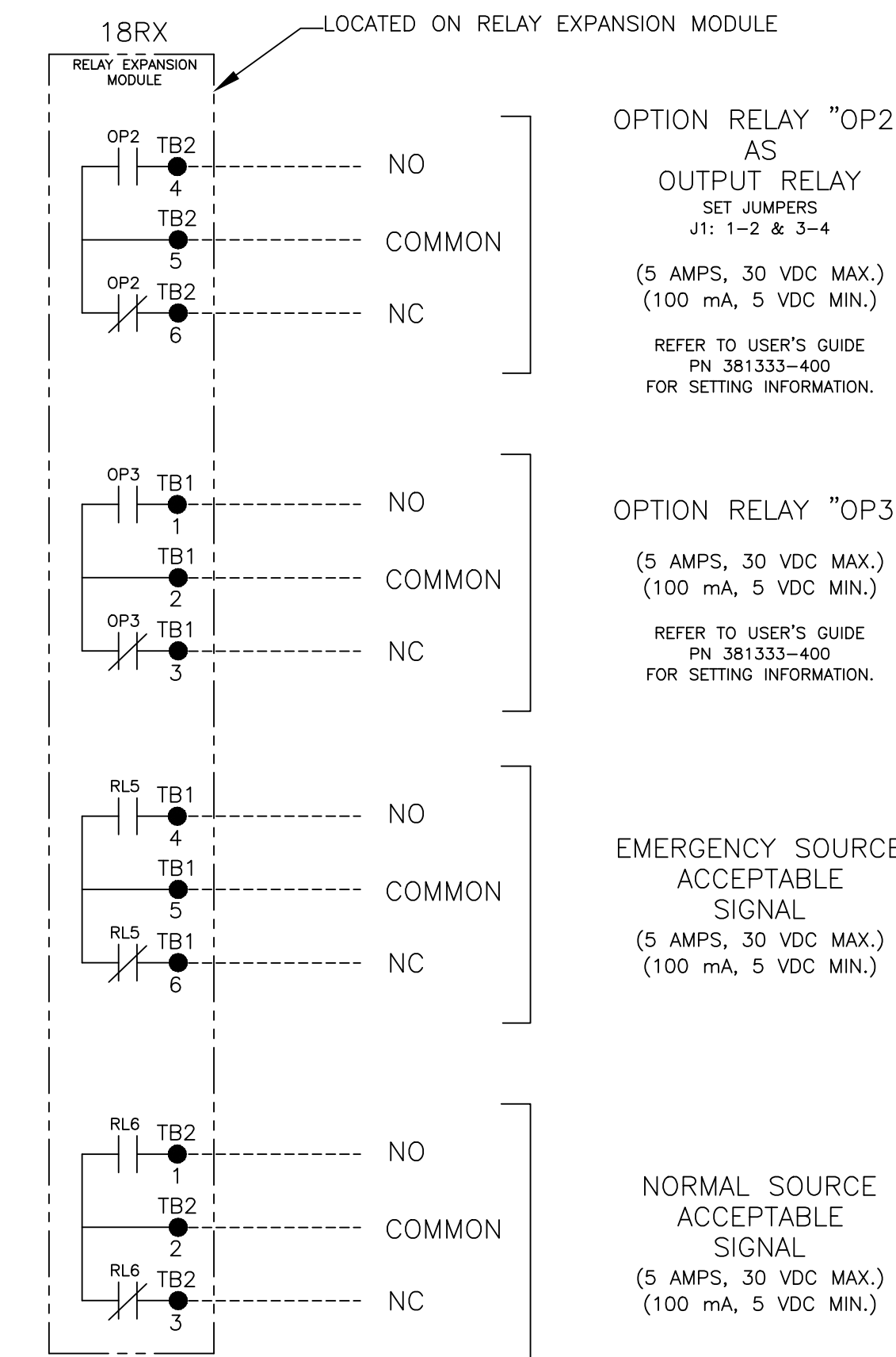

OPTION RELAY "OP2"
AS
OUTPUT RELAY
SET JUMPERS
J1: 1-2 & 3-4
(5 AMPS, 30 VDC MAX.)
(100 mA, 5 VDC MIN.)
REFER TO USER'S GUIDE
PN 381333-400
FOR SETTING INFORMATION.

OPTION RELAY "OP3"
(5 AMPS, 30 VDC MAX.)
(100 mA, 5 VDC MIN.)
REFER TO USER'S GUIDE
PN 381333-400
FOR SETTING INFORMATION.

EMERGENCY SOURCE
ACCEPTABLE
SIGNAL
(5 AMPS, 30 VDC MAX.)
(100 mA, 5 VDC MIN.)

NORMAL SOURCE
ACCEPTABLE
SIGNAL
(5 AMPS, 30 VDC MAX.)
(100 mA, 5 VDC MIN.)

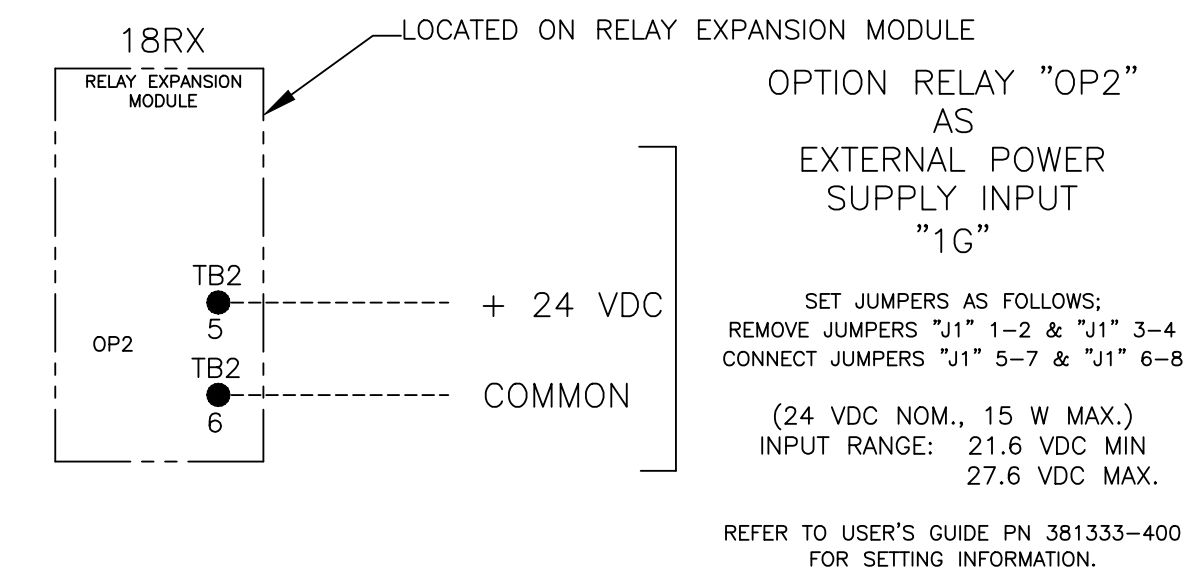
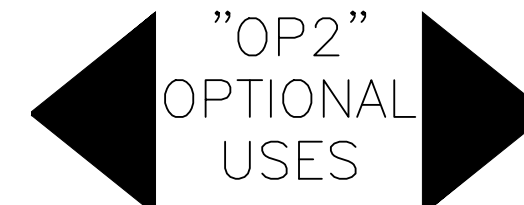

OPTION RELAY "OP2"
AS
EXTERNAL POWER
SUPPLY INPUT
"1G"
SET JUMPERS AS FOLLOWS:
REMOVE JUMPERS "J1" 1-2 & "J1" 3-4
CONNECT JUMPERS "J1" 5-7 & "J1" 6-8
(24 VDC NOM., 15 W MAX.)
INPUT RANGE: 21.6 VDC MIN
27.6 VDC MAX.
REFER TO USER'S GUIDE PN 381333-400
FOR SETTING INFORMATION.

OPTIONAL ACCESSORY 18RX1 (SECOND RELAY EXPANSION MODULE)

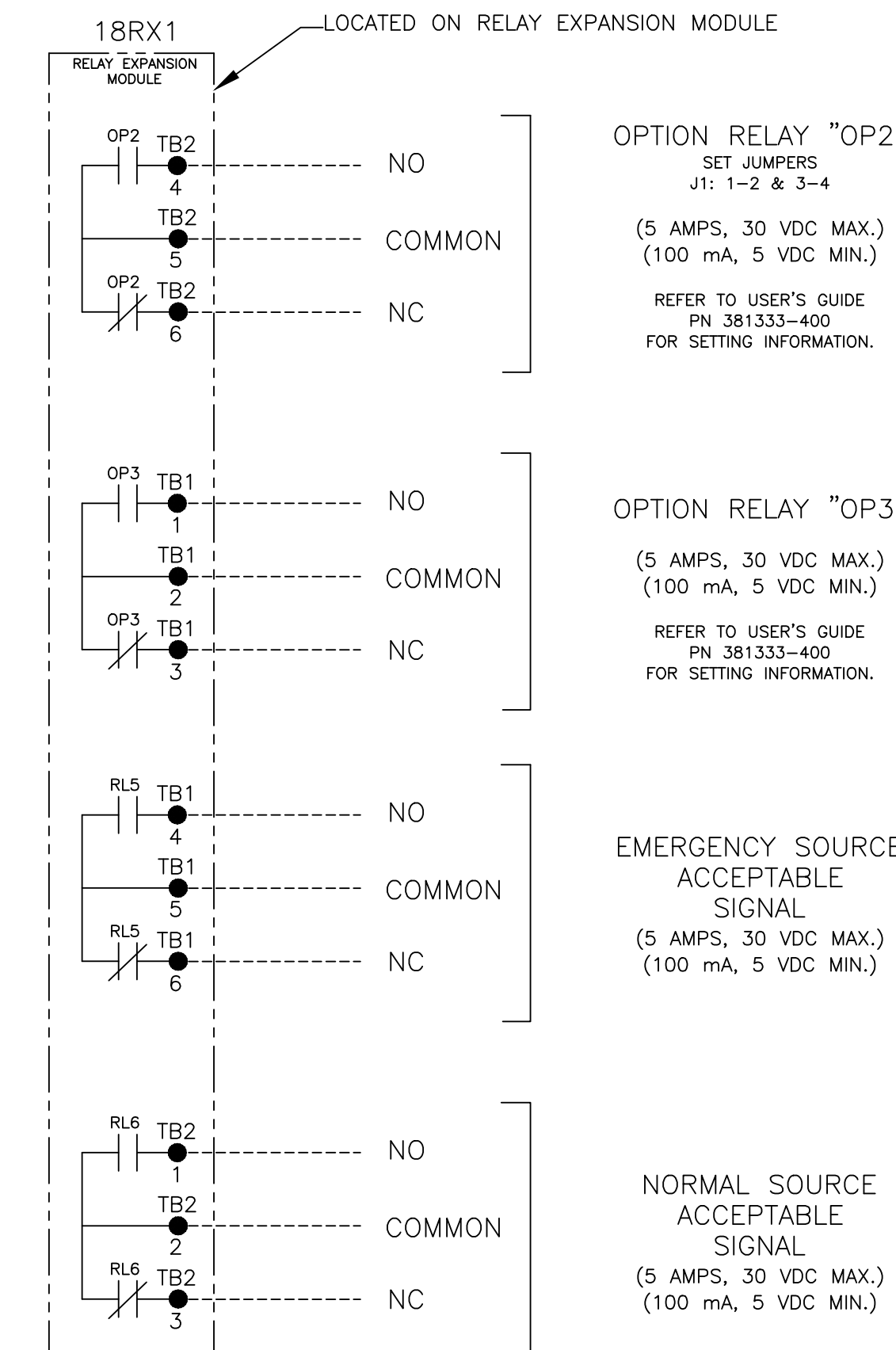

OPTION RELAY "OP2"
SET JUMPERS
J1: 1-2 & 3-4
(5 AMPS, 30 VDC MAX.)
(100 mA, 5 VDC MIN.)
REFER TO USER'S GUIDE
PN 381333-400
FOR SETTING INFORMATION.

OPTION RELAY "OP3"
(5 AMPS, 30 VDC MAX.)
(100 mA, 5 VDC MIN.)
REFER TO USER'S GUIDE
PN 381333-400
FOR SETTING INFORMATION.

EMERGENCY SOURCE
ACCEPTABLE
SIGNAL
(5 AMPS, 30 VDC MAX.)
(100 mA, 5 VDC MIN.)

NORMAL SOURCE
ACCEPTABLE
SIGNAL
(5 AMPS, 30 VDC MAX.)
(100 mA, 5 VDC MIN.)

B	243244	DL	JPB	07/10/13
A	242580	SDH	SDH	5/30/13
-	242255	SDH	SDH	5/6/13

PROJECT NAME:		REV. TO SHEET	ECN NO.	BY	APP.	DATE
WIRING DIAGRAM						
300 SERIES E3ATS/E3NTS, SINGLE PHASE 260 & 400 AMPS		ASSEMBLY REF. NO.		COMPUTER GENERATED DRAWING		
"E" FRAME, GROUP G CONTROLS		SCALE 1:1		SIZE DS		
DRAWN BY	SDH	DATE	5/6/13	PROPERTY OF ASCO POWER TECHNOLOGIES. USE PERMITTED FOR OUR WORK ONLY. ALL RIGHTS OF DESIGN OR INVENTION ARE RESERVED.		
CHECKED				DWG. NO. 978742		
PROJECT APPROVAL				DRAWING REV. B		
FINAL APPROVAL	SDH	DATE	5/6/13	ECN NO. 243244		
ASCO POWER TECHNOLOGIES, L.P. FLORHAM PARK, NEW JERSEY 07932 U.S.A.		SHEET 2 OF 6				

MAIN POWER POLES

TS OPERATOR CIRCUIT

EMERGENCY

NORMAL

OPTIONAL SWITCHING NEUTRAL
OPTIONAL OVERLAPPING NEUTRAL

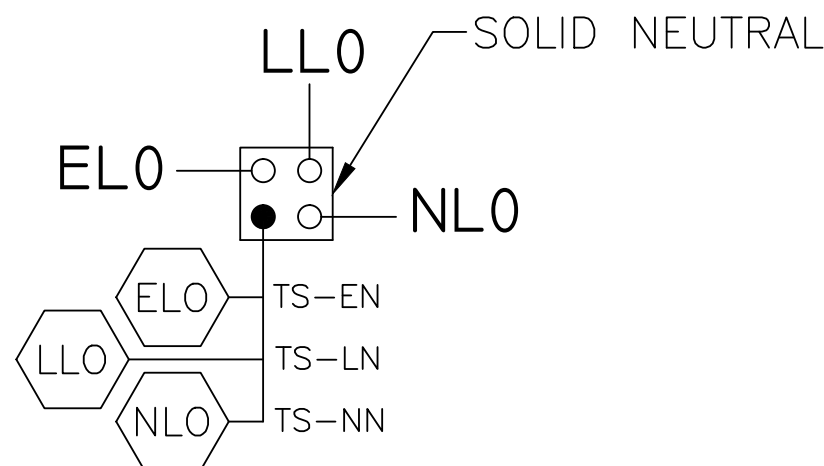
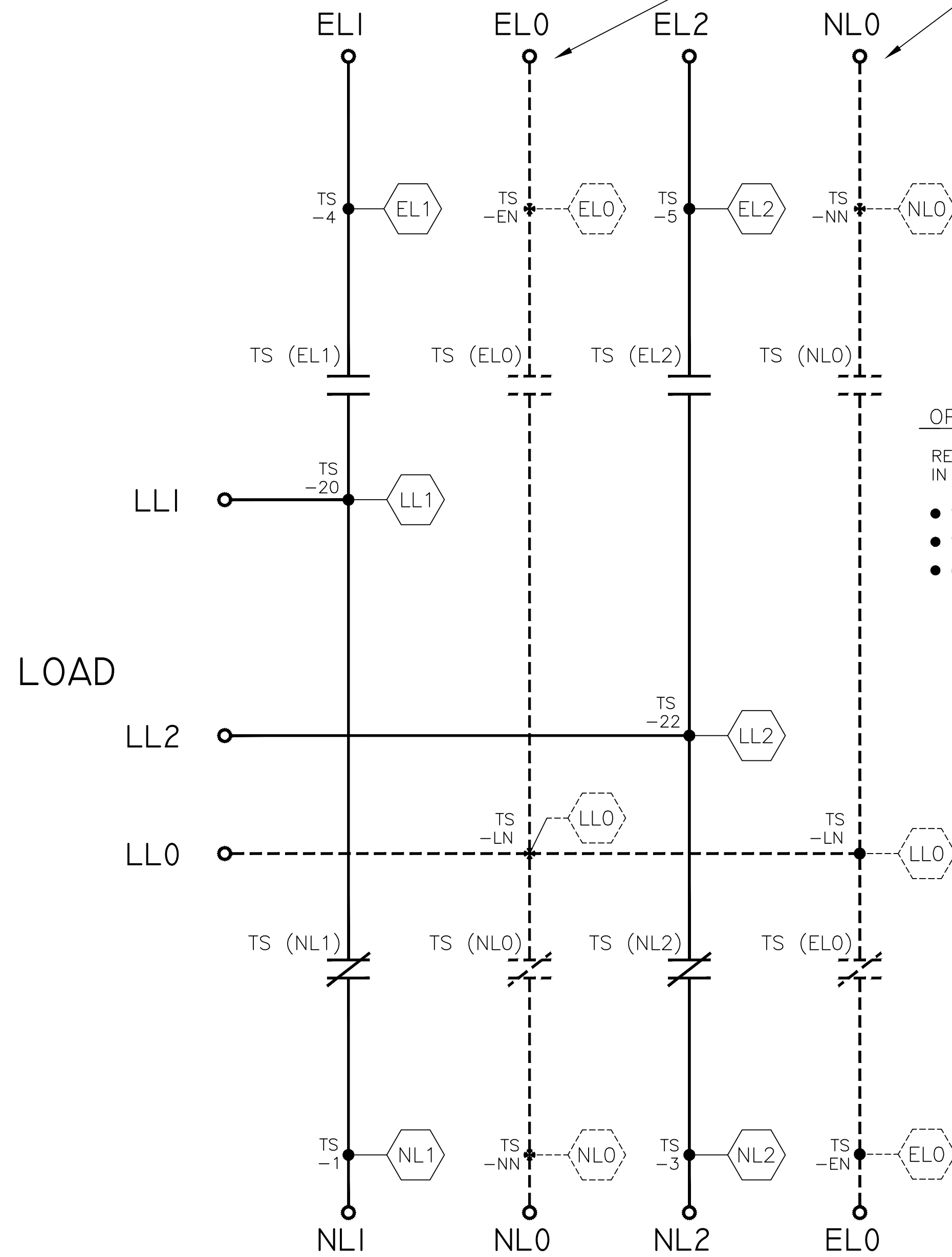

OPTIONAL NEUTRAL TYPES

REFER TO "EXPLANATION OF CATALOG NUMBER CODES" IN CATALOG NUMBER CHART ON SHEET 1.

- SOLID BUS PLATE
- SWITCHING (LOCATED BETWEEN L1 & L2 POLES)
- OVERLAPPING CONTACTS

NORMAL

NOTE:
ATS SHOWN CLOSED ON NORMAL SOURCE.

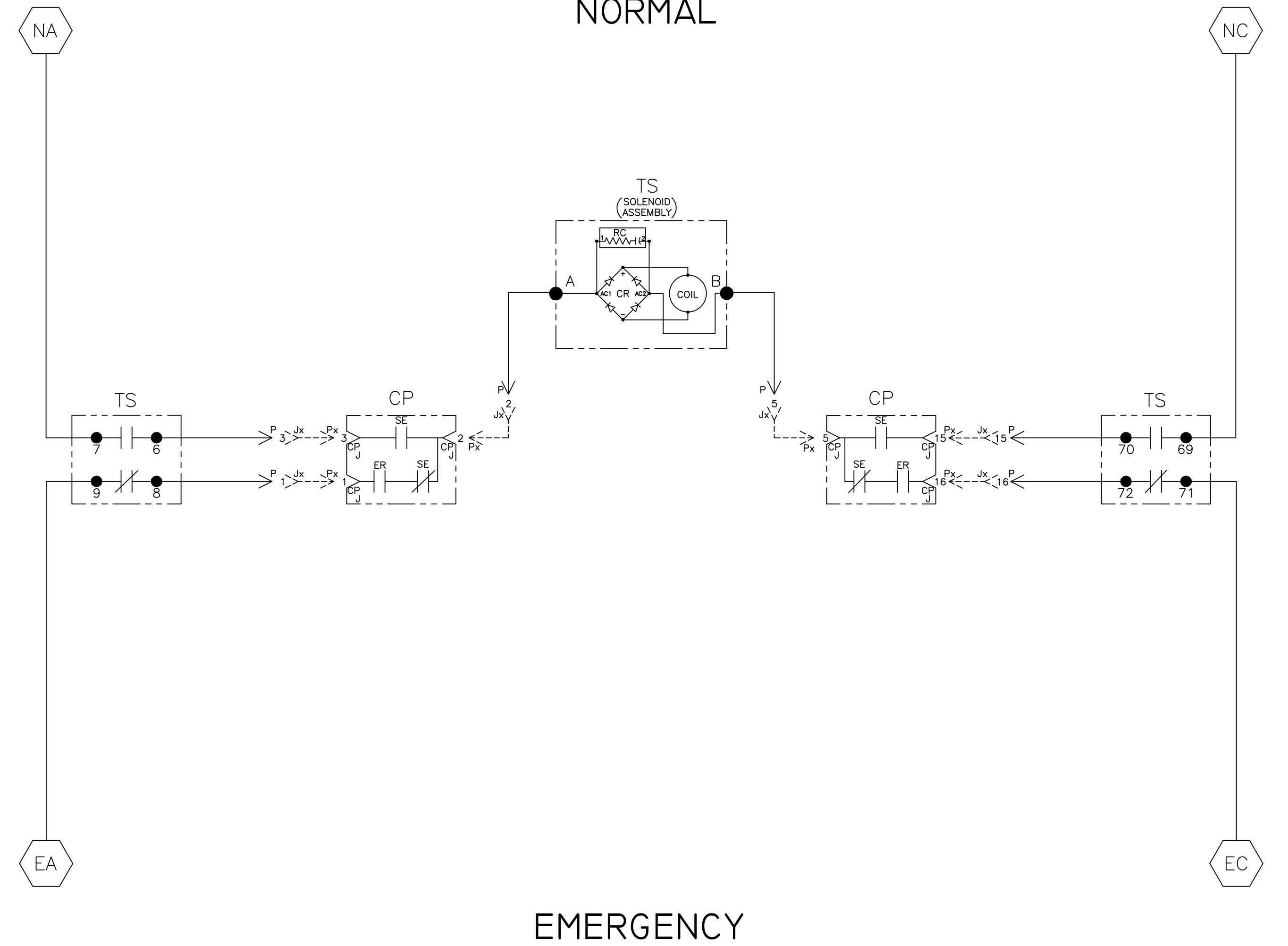

TS CONTROL CONTACTS		SOLENOID POSITION			
TS		CLOSED BEFORE		BEFORE CLOSED	
		NORMAL	TDC	TDC	EMERG
6-7					
69-70					
8-9					
71-72					

TDC (TOP DEAD CENTER)
TRANSFER SWITCH TEST & ADJUSTMENT PROCEDURE
SPECIFIES CONTROL CUT-OFF (CONTACT OPENING)
SETTING.

PROJECT NAME:		DIAGRAM		REV. TO SHEET	ECN NO.	BY	APP.	DATE
WIRING		300 SERIES E3ATS/E3NTS, SINGLE PHASE 260 & 400 AMPS "E" FRAME, GROUP G CONTROLS		COMPUTER GENERATED DRAWING		THIRD ANGLE PROJECTION		
DRAWN BY	SDH	DATE	5/6/13	SCALE	1:1	SIZE	DS	
CHECKED				DWG. NO.	978742			
PROJECT APPROVAL				DRAWING REV.	B	ECN NO.	243244	SHEET 3 OF 6
FINAL APPROVAL	SDH	DATE	5/6/13	ASCO POWER TECHNOLOGIES, L.P. FLORHAM PARK, NEW JERSEY 07932 U.S.A.				

B	243244	DL	JPB	07/10/13
SEE ECN--PHYSICAL DIAGRAM				
A	242580	SDH	SDH	5/30/13
SEE ECN				
-	242255	SDH	SDH	5/6/13
ISSUE				

NORMAL SOURCE CIRCUITS

NORMAL

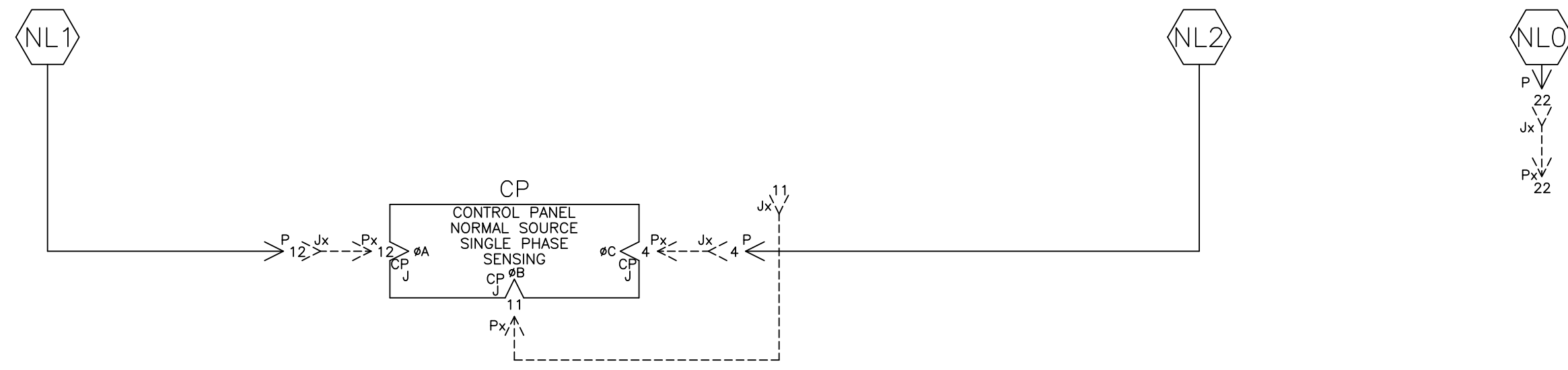

ADDITIONAL CIRCUITS

OPTIONAL ACCESSORY 23GA (LOAD CURRENT METERING)

SWITCH RATING	CT RATIO
260A	300:5A
400A	400:5A

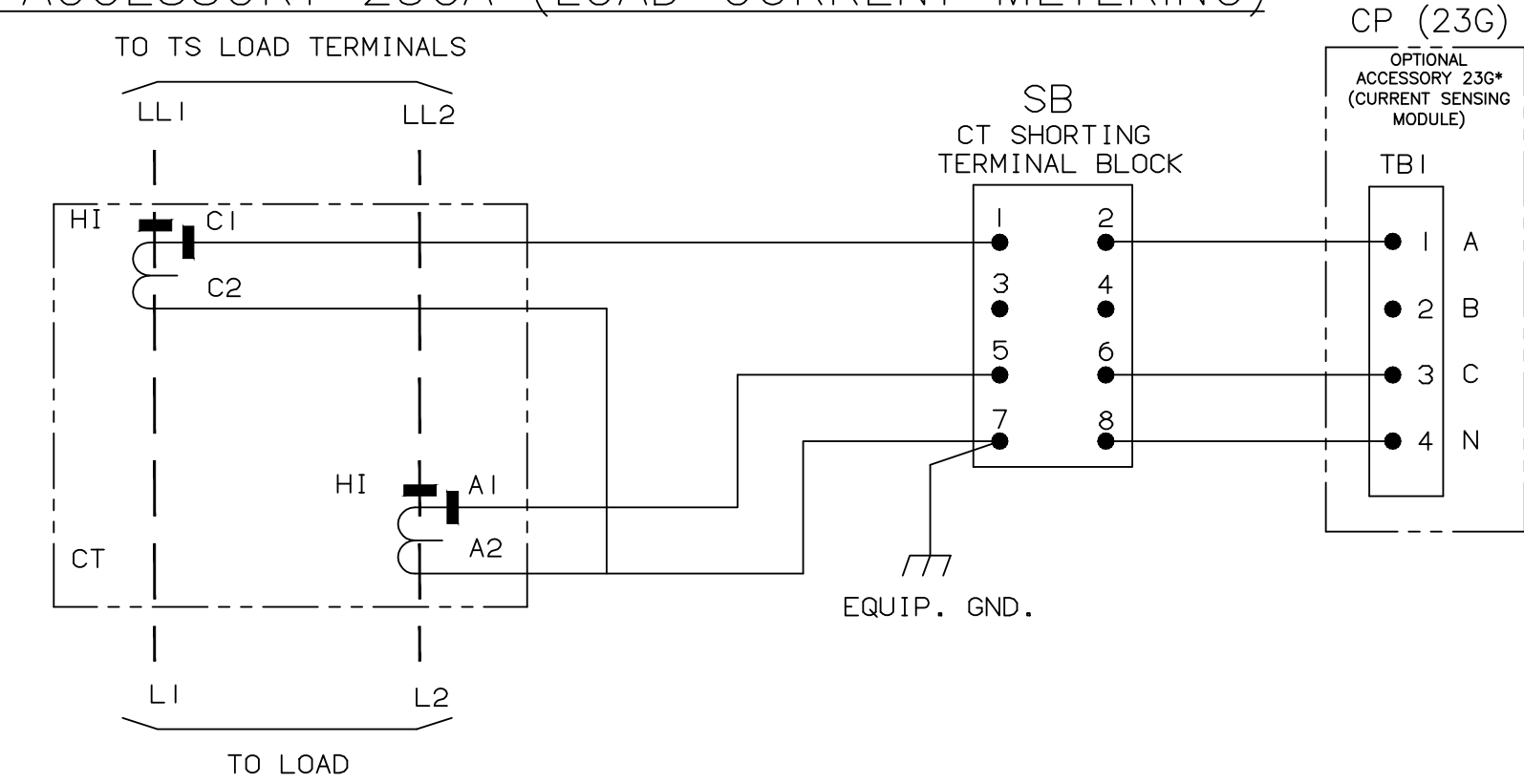

EMERGENCY SOURCE CIRCUITS

EMERGENCY

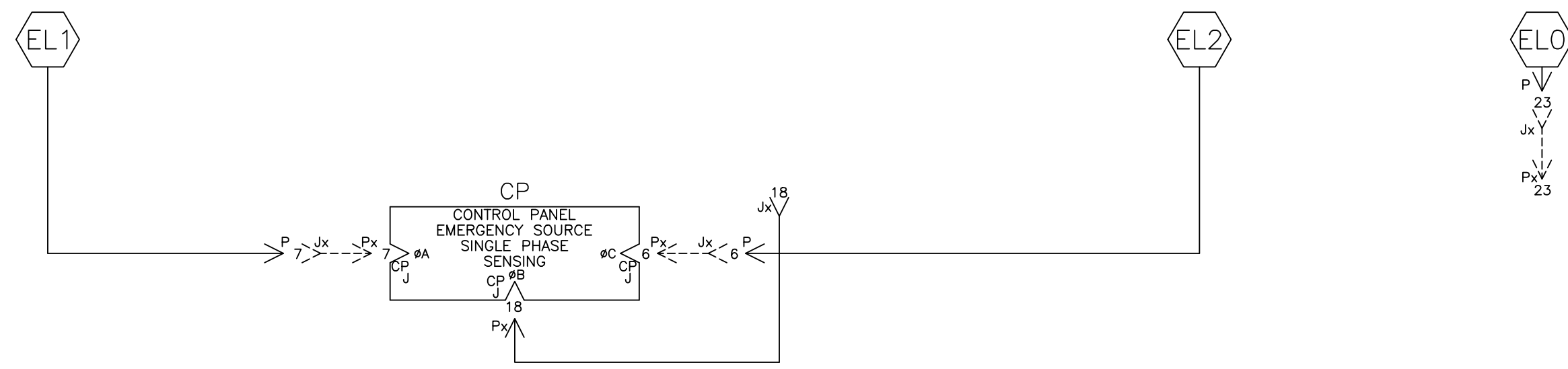

LOAD TERMINAL CIRCUITS

LOAD



CONTROL SIGNALS & INDICATION

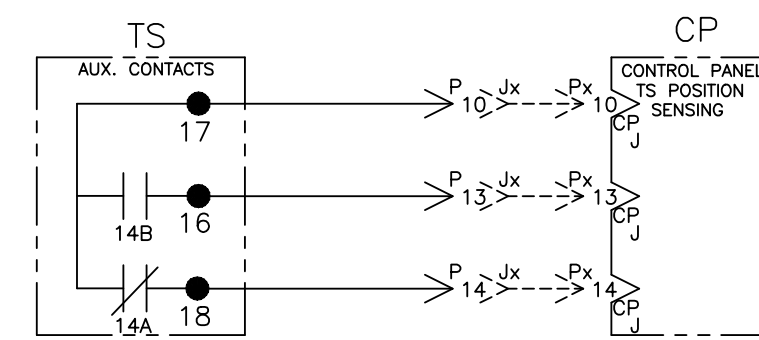

PROJECT NAME:		REV. TO SHEET	ECN NO.	BY	APP.	DATE
WIRING DIAGRAM		243244	DL	JPB		07/10/13
300 SERIES E3ATS/E3NTS, SINGLE PHASE 260 & 400 AMPS "E" FRAME, GROUP G CONTROLS		242580	SDH	SDH		5/30/13
		242255	SDH	SDH		5/16/13
		ISSUE				
DRAWN BY SDH 5/16/13		COMPUTER GENERATED DRAWING				
CHECKED		SCALE NONE SIZE DS				
PROJECT APPROVAL		DWG. NO. 978742				
FINAL APPROVAL SDH 5/16/13		DRAWING REV. B ECN NO. 243244 SHEET 4 OF 6				

ASCO POWER TECHNOLOGIES, L.P.
FLORHAM PARK, NEW JERSEY 07932 U.S.A.

PHYSICAL DIAGRAM

ENCLOSURE

DOOR (INSIDE)

OPTIONAL ACCESSORY 23GA

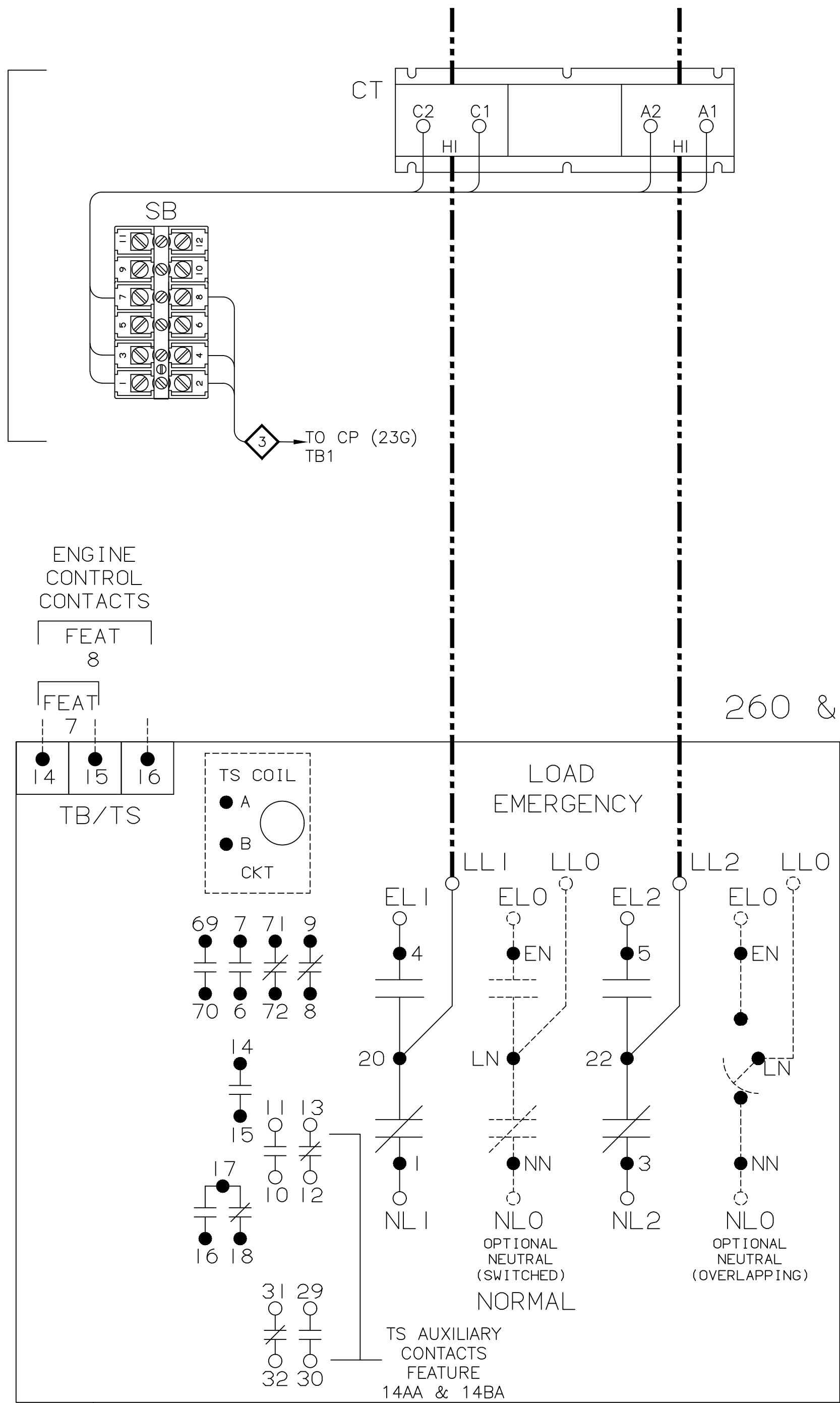

260 & 400 AMPS

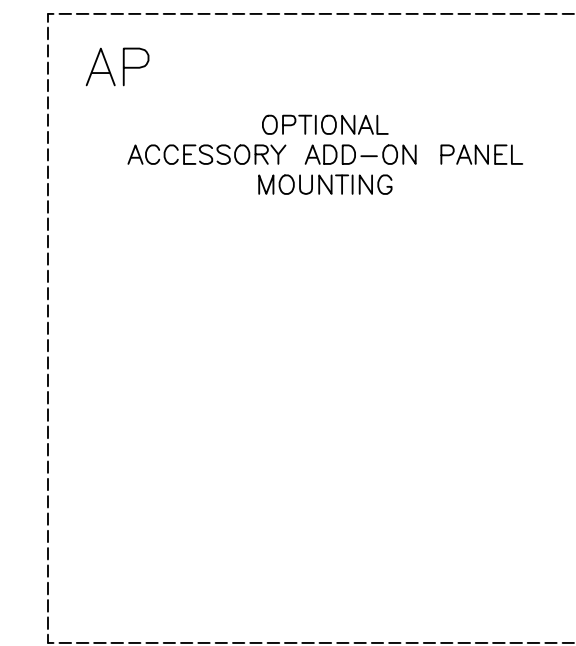
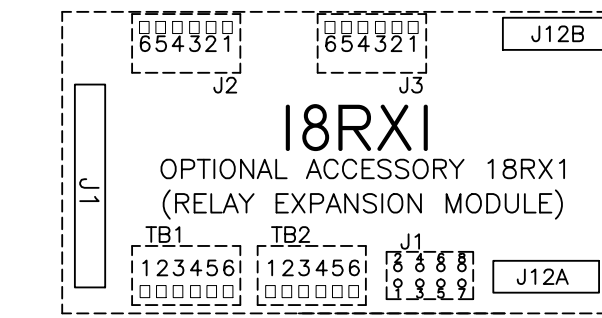
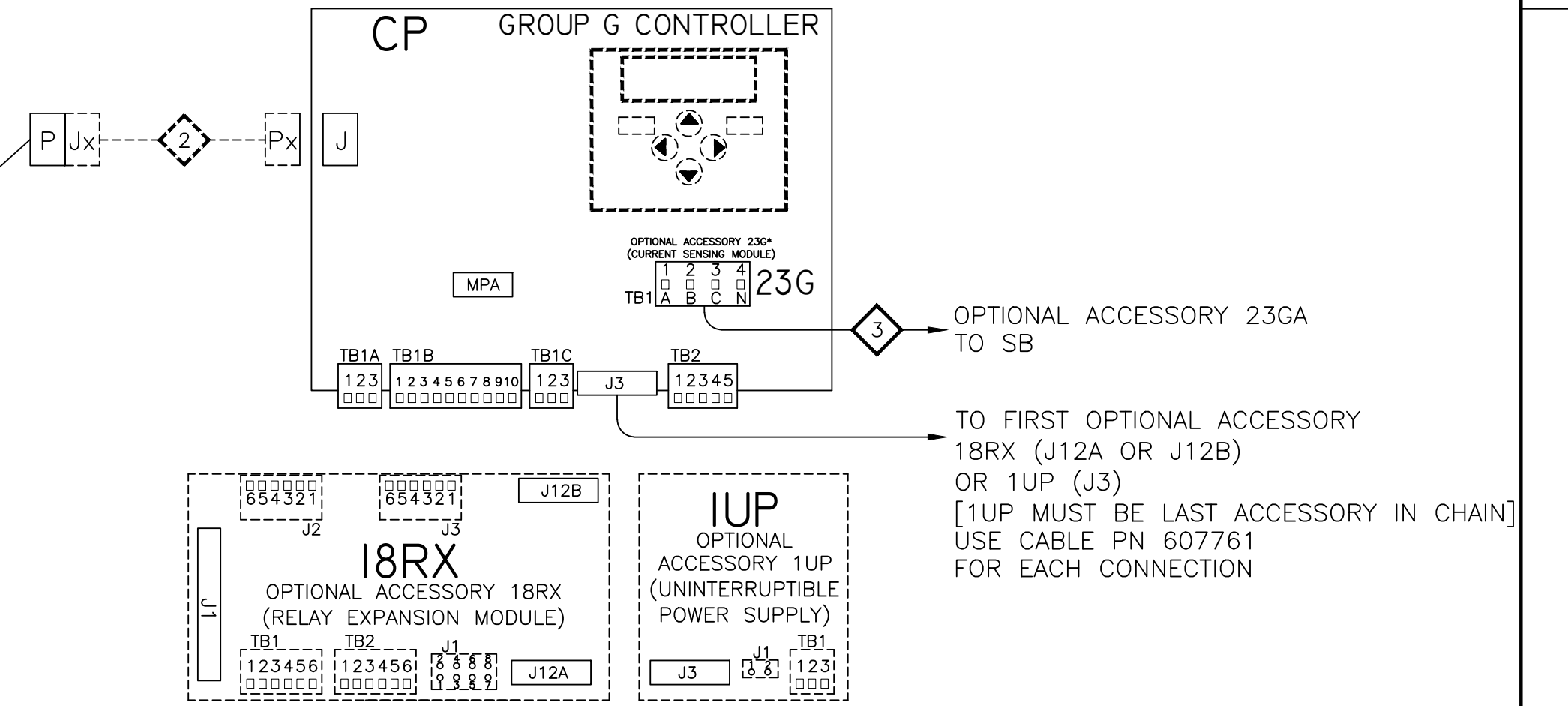
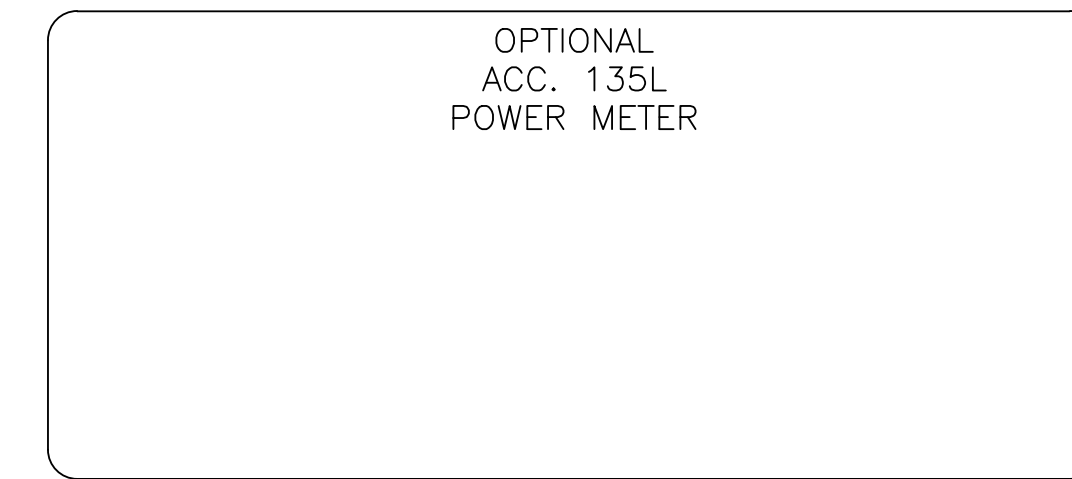
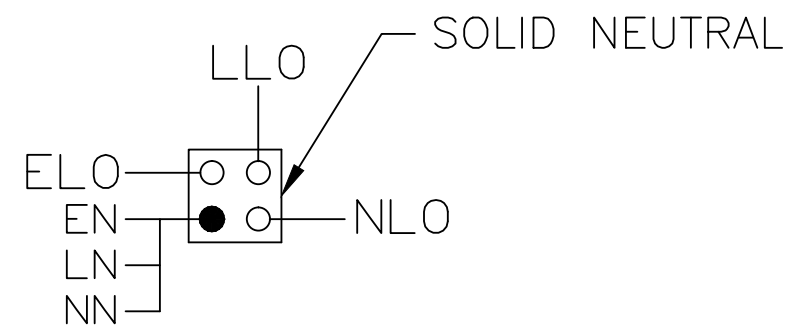

B	243244	DL	JPB	07/10/13
A	242580	SDH	SDH	5/30/13
-	242255	SDH	SDH	5/16/13

PROJECT NAME:		DIAGRAM		REV. TO SHEET	ECN NO.	BY	APP.	DATE
300 SERIES E3ATS/E3NTS, SINGLE PHASE 260 & 400 AMPS		"E" FRAME, GROUP G CONTROLS		SCALE NONE SIZE DS		THIRD ANGLE PROJECTION		
DRAWN BY	SDH	DATE	5/16/13	PROPERTY OF ASCO POWER TECHNOLOGIES. USE PERMITTED FOR OUR WORK ONLY. ALL RIGHTS OF DESIGN OR INVENTION ARE RESERVED.		COMPUTER GENERATED DRAWING		
CHECKED				MANUFACTURING TOLERANCES TO BE IN ACCORDANCE WITH ASCO PROCEDURE MP-1-003. FOR PLASTIC PARTS SEE MP-1-055.		DWG. NO. 978742		
PROJECT APPROVAL				ASCO POWER TECHNOLOGIES, L.P. FLORHAM PARK, NEW JERSEY 07932 U.S.A.		DRAWING REV. B ECN NO. 243244 SHEET 5 OF 6		

