

THREE PHASE WIRING FOR ASCO® SERIES 300 AUTOMATIC TRANSFER SWITCHES RATED 600, 800, 1000 & 1200 AMPERES WITH GROUP I CONTROLS

CONTROL FEATURES

- VOLTAGE AND FREQUENCY SENSING**
- DIFFERENTIAL TYPE VOLTAGE SENSING ON ALL PHASES OF NORMAL SOURCE. DROPOUT SETTING SELECTABLE AT 90, 85, 80 OR 70% OF NOMINAL. FACTORY SET AT 85%. PICKUP VOLTAGE ADJUSTABLE AT 90 OR 95% OF NOMINAL. (DEFAULT IS 95% IF DROPOUT IS SET TO 90%).
 - SINGLE PHASE VOLTAGE SENSING OF EMERGENCY SOURCE. NON-ADJUSTABLE DROPOUT SETTING AT 75% OF NOMINAL. NON-ADJUSTABLE PICKUP SETTING AT 90% OF NOMINAL.
 - FREQUENCY SENSING OF EMERGENCY SOURCE. NON-ADJUSTABLE DROPOUT SETTING AT 85% OF NOMINAL. NON-ADJUSTABLE PICKUP SETTING AT 95% OF NOMINAL.
- TIME DELAYS**
- MOMENTARY NORMAL SOURCE OUTAGE DELAY - ACTIVATED WHEN THE NORMAL SOURCE FAILS. DEACTIVATED WHEN THE NORMAL SOURCE IS ACCEPTABLE. PROVIDES A SELECTABLE (1 OR 3 SECOND) DELAY ON TRANSFER AND ENGINE STARTING SIGNALS. FACTORY SET AT 3 SECONDS. (REFER TO THE OPERATOR'S MANUAL FURNISHED WITH EACH TRANSFER SWITCH REGARDING CONTROL PANEL SETTINGS).
 - TRANSFER TO EMERGENCY DELAY - ACTIVATED AFTER THE MOMENTARY NORMAL SOURCE OUTAGE DELAY EXPIRES AND THE EMERGENCY SOURCE IS SENSIBLE TO BE ACCEPTABLE. TRANSFER TO EMERGENCY IS COMMITTED TO ON INITIATION OF DELAY. DEACTIVATED WHEN THE EMERGENCY SOURCE IS UNACCEPTABLE. PROVIDES AN ADJUSTABLE DELAY FROM 0 TO 5 MINUTES. FACTORY SET AT 0 MINUTES. (REFER TO OPERATOR'S MANUAL FURNISHED WITH EACH TRANSFER SWITCH REGARDING CONTROL PANEL SETTINGS).
 - RETRANSFER TO NORMAL DELAY - ACTIVATED WHEN THE NORMAL SOURCE IS ACCEPTABLE. DEACTIVATED WHEN THE NORMAL SOURCE FAILS WITH NO TRANSFER TO NORMAL. ALSO DEACTIVATED WHEN THE EMERGENCY SOURCE FAILS WHILE THE NORMAL SOURCE IS ACCEPTABLE WITH TRANSFER TO NORMAL. ADJUSTABLE DELAY FROM 1 SECOND TO 30 MINUTES. FACTORY SET TO 30 MINUTES. (REFER TO THE OPERATOR'S MANUAL FURNISHED WITH EACH TRANSFER SWITCH REGARDING CONTROL PANEL SETTINGS).
 - UNLOADED RUNNING (ENGINE COOL DOWN) DELAY - ACTIVATED ON EXPIRATION OF RETRANSFER TO NORMAL DELAY OR FOLLOWING EXPIRATION OF THE NORMAL SOURCE OUTAGE DELAY WITHOUT A COMMIT TO TRANSFER TO EMERGENCY. NON-ADJUSTABLE DELAY OF 5 MINUTES.
 - MOMENTARY EMERGENCY SOURCE OUTAGE DELAY - ACTIVATED WHEN THE SWITCH IS IN THE EMERGENCY POSITION AND THE EMERGENCY SOURCE FAILS. FACTORY SET AT 4 SECONDS. RESET IF EMERGENCY RESTORES WITHIN 4 SECONDS.

REMOTE CONTROL FEATURES

THE FOLLOWING CONTROL PANEL INPUTS PROVIDE REMOTE CONTROL FUNCTIONS FOR THE AUTOMATIC TRANSFER SWITCH. EACH CONTROL FUNCTION CAN BE IMPLEMENTED BY THE CUSTOMER PROVIDING THE FORM OF CONTROL CONTACT DESCRIBED. EACH CONTROL CONTACT MUST BE SUITABLE FOR A 5 VDC LOW ENERGY CIRCUIT. EACH CONTROL FEATURE IS ACTIVATED BY SETTING A DIP TYPE SELECTOR SWITCH ON THE CONTROL PANEL. (REFER TO THE OPERATOR'S MANUAL FURNISHED WITH EACH TRANSFER SWITCH REGARDING CONTROL PANEL SETTINGS).

- REMOTE TEST FEATURE - REQUIRES A CUSTOMER SUPPLIED, REMOTE, NORMALLY CLOSED CONTACT. OPENING OF THE CONTACT SIMULATES A FAILURE OF THE NORMAL SOURCE SIMILAR TO THE SEQUENCE OUTLINED FOR THE TRANSFER SWITCH TEST PUSH-BUTTON. THE TRANSFER SWITCH WILL REMAIN CONNECTED TO THE EMERGENCY SOURCE UNDER ALL CONDITIONS WHILE THE CONTACT IS OPEN.
- REMOTE TRANSFER TO EMERGENCY FEATURE - REQUIRES A CUSTOMER SUPPLIED, REMOTE, NORMALLY CLOSED CONTACT. OPENING OF THE CONTACT CAUSES ENGINE START AND TRANSFER TO THE EMERGENCY SOURCE. RECLOSURE OF THE CONTACT ACTIVATES THE RETRANSFER TO NORMAL DELAY PRIOR TO RETRANSFER. IN THE EVENT THAT THE EMERGENCY SOURCE FAILS WHILE THE TRANSFER SWITCH IS CONNECTED TO EMERGENCY AND THE REMOTE CONTACT IS OPEN, THE TRANSFER SWITCH WILL AUTOMATICALLY RETRANSFER TO THE NORMAL SOURCE.
- INHIBIT TRANSFER TO EMERGENCY FEATURE - REQUIRES A CUSTOMER SUPPLIED, REMOTE, NORMALLY CLOSED CONTACT. OPENING OF THE CONTACT WILL PROHIBIT THE TRANSFER SWITCH FROM TRANSFERRING TO THE EMERGENCY SOURCE WHILE CONNECTED TO THE NORMAL SOURCE.
- BYPASS TRANSFER TIME DELAY FEATURE - REQUIRES A CUSTOMER SUPPLIED, REMOTE, NORMALLY CLOSED CONTACT. OPENING OF THE CONTACT BYPASSES THE RETRANSFER TO NORMAL DELAY IF ACTIVE.

FIELD CONNECTIONS

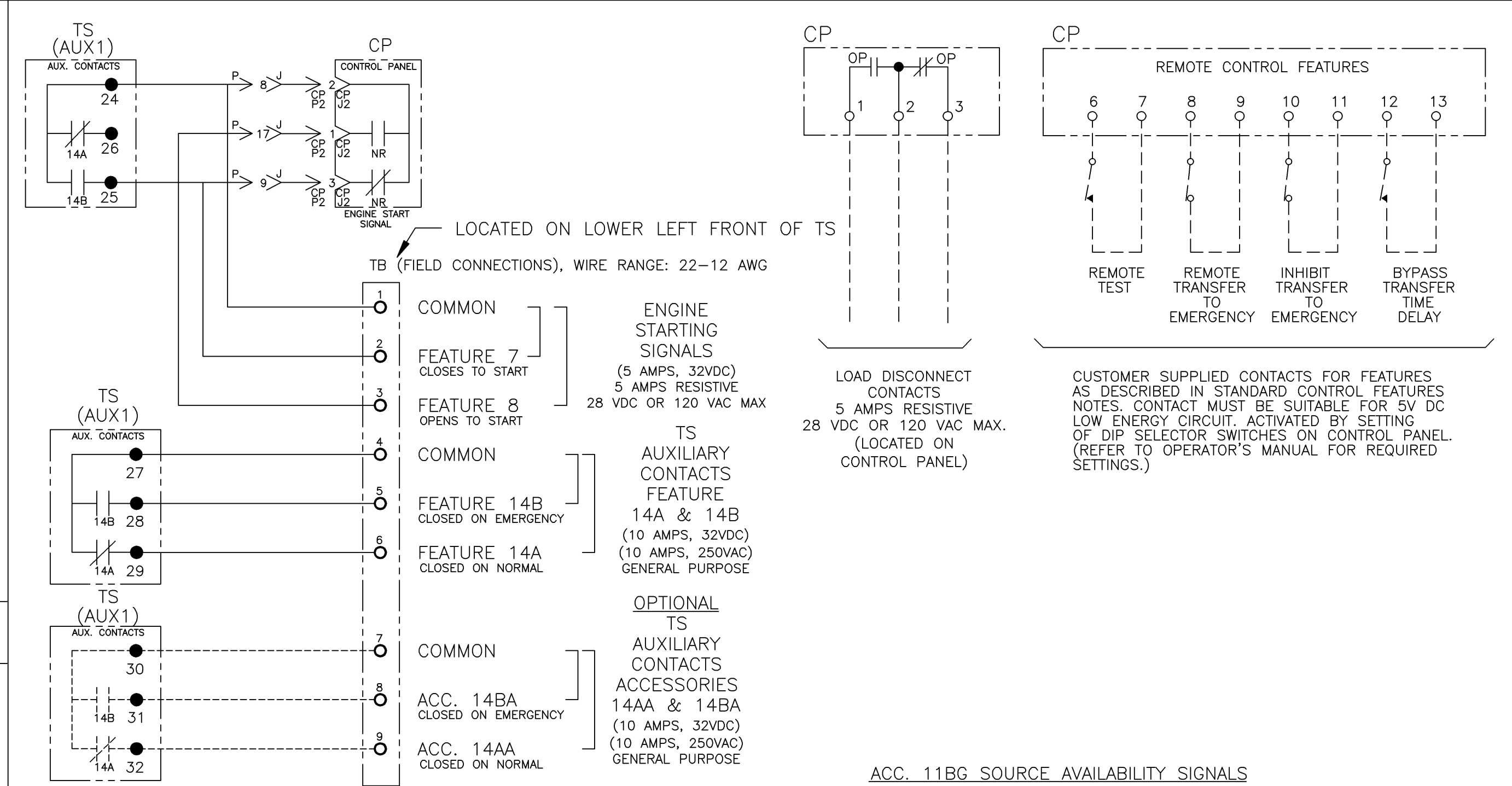

GENERAL NOTES

- SWITCH SHOWN DE-ENERGIZED CONNECTED TO NORMAL SOURCE. DEVICE SYMBOLS AND DESIGNATIONS ARE IN ACCORDANCE WITH NEMA PUB. ICS 1-1983, PART 1-101A.
- ALL WIRING IS #16 AWG, TINNED, STRANDED COPPER UNLESS OTHERWISE INDICATED.
- INDICATES CUSTOMER CONNECTION POINTS.
- INDICATES FACTORY CONNECTION POINTS.
- CONNECTION POINTS THAT HAVE BOTH CUSTOMER CONNECTIONS AND FACTORY CONNECTIONS ARE SHOWN OPEN AS CUSTOMER CONNECTION POINTS.
- THE TRANSFER UNIT IS MOUNTED ON THE BACK INSIDE SURFACE OF THE ENCLOSURE. THE CONTROL PANEL AND ANY OPTIONAL ACCESSORIES ARE MOUNTED ON THE INSIDE SURFACE OF THE DOOR.
- AN OPERATOR'S MANUAL IS FURNISHED WITH EACH AUTOMATIC TRANSFER SWITCH. REFER TO THIS PUBLICATION PRIOR TO INSTALLATION AND OPERATION OF THE SWITCH.
- GROUND STRAP ON CONTROL PANEL IS AFFIXED TO CHASSIS (ENCLOSURE) AT LOWER LEFT CONTROL PANEL MOUNTING STUD.

OPTIONAL ACCESSORIES

ACCESSORY 11BG - PROGRAMMABLE ENGINE EXERCISER & SOURCE AVAILABILITY SIGNAL MODULES

PROGRAMMABLE ENGINE EXERCISER: A PROGRAMMABLE SEVEN (7) DAY OR FOURTEEN (14) DAY ELECTRONIC TIME SWITCH FOR AUTOMATIC WEEKLY TESTING OF THE ENGINE GENERATOR SET EITHER WITH OR WITHOUT LOAD. EACH DAY OF THE WEEK IS INDIVIDUALLY PROGRAMMABLE. THE TIME OF DAY IS PRESERVED BY A BATTERY BUILT INTO THE GROUP 1 TRANSFER SWITCH CONTROL PANEL.

THE FEATURE IS ACTIVATED BY SETTING A DIP SELECTOR SWITCH ON THE CONTROL PANEL. ENGINE START WITH OR WITHOUT LOAD TRANSFER IS SELECTED WITH A SECOND DIP SELECTOR SWITCH ON THE CONTROL PANEL. (REFER TO THE OPERATOR'S MANUAL FURNISHED WITH EACH TRANSFER SWITCH REGARDING CONTROL PANEL AND TIMER SETTINGS).

SOURCE AVAILABILITY SIGNALING: ONE FORM C CONTACT EACH FOR THE NORMAL & EMERGENCY SOURCES SIGNAL THE ACCEPTABILITY OF THE SOURCE AS SENSED BY THE GROUP 1 CONTROL PANEL. THE SIGNAL CONTACTS OPERATE IN CONJUNCTION WITH THE SOURCE AVAILABILITY LED STATUS INDICATION PROVIDED ON THE OPERATOR INTERFACE. FIELD WIRING TERMINALS ARE PROVIDED AS SHOWN, LOCATED ON THE INSIDE DOOR BEHIND THE OPERATOR INTERFACE. CONTACTS RATED 2 AMPS @ 30VDC, 0.5 AMPS @ 125 VAC (RESISTIVE).

SERIAL COMMUNICATIONS INTERFACE (ACCESSORY 72A)
RS-485 SERIAL INTERFACE TO CONTROL PANEL FOR REMOTE MONITORING AND CONTROL FROM ASCO COMMUNICATIONS BASED PRODUCTS.

- ACC. 14AA (2) AUXILIARY CONTACT CLOSED ON NORMAL.
- ACC. 14BA (2) AUXILIARY CONTACT CLOSED ON EMERGENCY.
- ACC. 44A STRIP HEATER, THERMOSTAT & TB. CUSTOMER POWER SUPPLY 120VAC.
- ACC. 44G STRIP HEATER, THERMOSTAT & TRANSFORMER. POWER SUPPLY FROM LOAD TERMINALS OF TRANSFER SWITCH.

OPERATOR INTERFACE INDICATORS & CONTROLS MEMBRANE TYPE

- TRANSFER SWITCH TEST - MOMENTARY PUSH-BUTTON TO SIMULATE NORMAL SOURCE FAILURE SEQUENCE OF OPERATION. PRESS AND HOLD FOR AT LEAST 15 SECONDS TO ALLOW TIME FOR ENGINE-GENERATOR SET TO START.
- BYPASS TIME DELAY - MOMENTARY PUSH-BUTTON TO BYPASS EITHER THE TRANSFER TO EMERGENCY DELAY, ENGINE EXERCISER PERIOD OR THE RETRANSFER TO NORMAL DELAY DEPENDING ON WHICH DELAY IS ACTIVE AT THE TIME THE PUSH-BUTTON IS ACTIVATED.
- SET ENGINE EXERCISER - MOMENTARY PUSH-BUTTON TO ACTIVATE A SEVEN (7) DAY TIMER FOR AUTOMATIC WEEKLY TESTING OF THE ENGINE GENERATOR SET EITHER WITH OR WITHOUT LOAD TRANSFER. THE TIMER IS POWERED BY A NON-RECHARGEABLE 9V BATTERY WHEN NORMAL AND EMERGENCY SOURCES ARE UNAVAILABLE. DEPRESSING THE MOMENTARY PUSH-BUTTON FOR 5 SECONDS SETS THE TIME OF WEEK AT WHICH TESTING IS TO OCCUR. THE FEATURE IS ACTIVATED BY SETTING A DIP SELECTOR SWITCH ON THE CONTROL PANEL. ENGINE START WITH OR WITHOUT LOAD TRANSFER IS SELECTED WITH A SECOND DIP SELECTOR SWITCH ON THE CONTROL PANEL. FACTORY SET TO DISABLED, NO LOAD. (REFER TO THE OPERATOR'S MANUAL FURNISHED WITH EACH TRANSFER SWITCH REGARDING CONTROL PANEL SETTINGS).
- LOAD CONNECTED TO INDICATORS GREEN LED INDICATOR TO INDICATE WHEN THE TRANSFER SWITCH LOAD IS CONNECTED TO THE NORMAL SOURCE. RED LED INDICATOR TO INDICATE WHEN THE TRANSFER SWITCH IS CONNECTED TO THE EMERGENCY SOURCE.
- SOURCE AVAILABLE INDICATORS GREEN LED INDICATOR TO INDICATE WHEN THE NORMAL SOURCE IS AVAILABLE. RED LED INDICATOR TO INDICATE WHEN THE EMERGENCY SOURCE IS AVAILABLE.

LOAD DISCONNECT FEATURE

ONE SET OF FORM C CONTACTS (1 N/O & 1 N/C) THAT CHANGE POSITION ON ACTIVATION OF A SELECTABLE TIME DELAY BEFORE TRANSFER (LD TDBT) AND RESET EITHER IMMEDIATELY FOLLOWING TRANSFER OR FOR THE SAME DELAY AS SET FOR PRE-SIGNAL BEFORE TRANSFER. SELECTABLE AS 0, 3, 10 OR 20 SECONDS. FACTORY SET AT 0. (REFER TO THE OPERATOR'S MANUAL FURNISHED WITH EACH TRANSFER SWITCH REGARDING CONTROL PANEL SETTINGS). OUTPUT CONTACTS (OP) ARE RATED 5 AMPS RESISTIVE AT 28 VDC OR 120 VAC MAXIMUM.

MOTOR LOAD TRANSFER FEATURE

INPHASE TRANSFER CONTROL LOGIC TO INITIATE AN INPHASE TRANSFER OF MOTOR LOADS BETWEEN LIVE SOURCES. USED TO HELP PREVENT NUISANCE TRIPPING OF DISTRIBUTION CIRCUIT BREAKERS AND POSSIBLE DAMAGE TO MECHANICAL LOADS ASSOCIATED WITH OUT OF PHASE TRANSFER. ACTIVATED BY SETTING A DIP SWITCH ON THE CONTROL PANEL. FACTORY SET AS DISABLED. (REFER TO OPERATOR'S MANUAL FURNISHED WITH EACH TRANSFER SWITCH REGARDING CONTROL PANEL SETTINGS).

TS FRAME	BASE CATALOG TYPE	NEUTRAL TYPE	PHASE POLES	AMPS	VOLT CODE	CONTROLLER	OPTIONAL ACCESSORY	ENCLOSURE CODE	EXPLANATION OF CATALOG NUMBER CODES		
									NEUTRAL TYPE	VOLTAGE CODES	ENCLOSURE CODES
H	300	B	3	600, 800, 1000, 1200	H, J, K, L, M, N, Q, R	1	X	F, G	CODE	DESCRIPTION	ENCLOSURE CODES
									CODE	DESCRIPTION	ENCLOSURE CODES
									1	OPEN TYPE (NO ENCLOSURE) GENERAL PURPOSE, INDOOR	
									3R	OUTDOOR, RAINPROOF, SLEET & ICE RESISTANT INDOOR/OUTDOOR, WATERTIGHT & DUSTTIGHT	
									L	INDOOR, INDUSTRIAL ENVIRONMENTS, OILTIGHT & DUSTTIGHT	
									Q	575	
									R	600	

CATALOG NUMBER IDENTIFIED TO _____
S.O. _____

BY _____
DATE _____

FORM REV G

PROJECT NAME: _____

WIRING DIAGRAM

SERIES H300 ATS 3PH 600-1200 AMPS
"H" FRAME, GROUP 1 CONTROLS

THIRD ANGLE PROJECTION

DRAWN BY	BWM	DATE	4/01	MANUFACTURING TOLERANCES TO BE IN ACCORDANCE WITH ASCO PROCEDURE MP-1-003. FOR PLASTIC PARTS SEE MP-1-055	ASSEM. REF. NO.
CHECKED	BK	DATE	4/10/01	PROPERTY OF ASCO POWER TECHNOLOGIES. USE PERMITTED FOR OUR WORK ONLY. ALL RIGHTS OF DESIGN OR INVENTION ARE RESERVED.	
PROJECT APPROVAL					
FINAL APPROVAL	WK	DATE	4/10/01		

SCALE: NONE SIZE: DS

DWG. NO.: 717501

COMPUTER GENERATED DRAWING

ASCO POWER TECHNOLOGIES, L.P.
FLORHAM PARK, NEW JERSEY 07832 U.S.A.

DRAWING REV: H ECN NO: 234078 SHEET 1 OF 4

8

7

6

5

4

3

2

1

MAIN POWER POLES

TS OPERATOR CIRCUIT

EMERGENCY

NORMAL

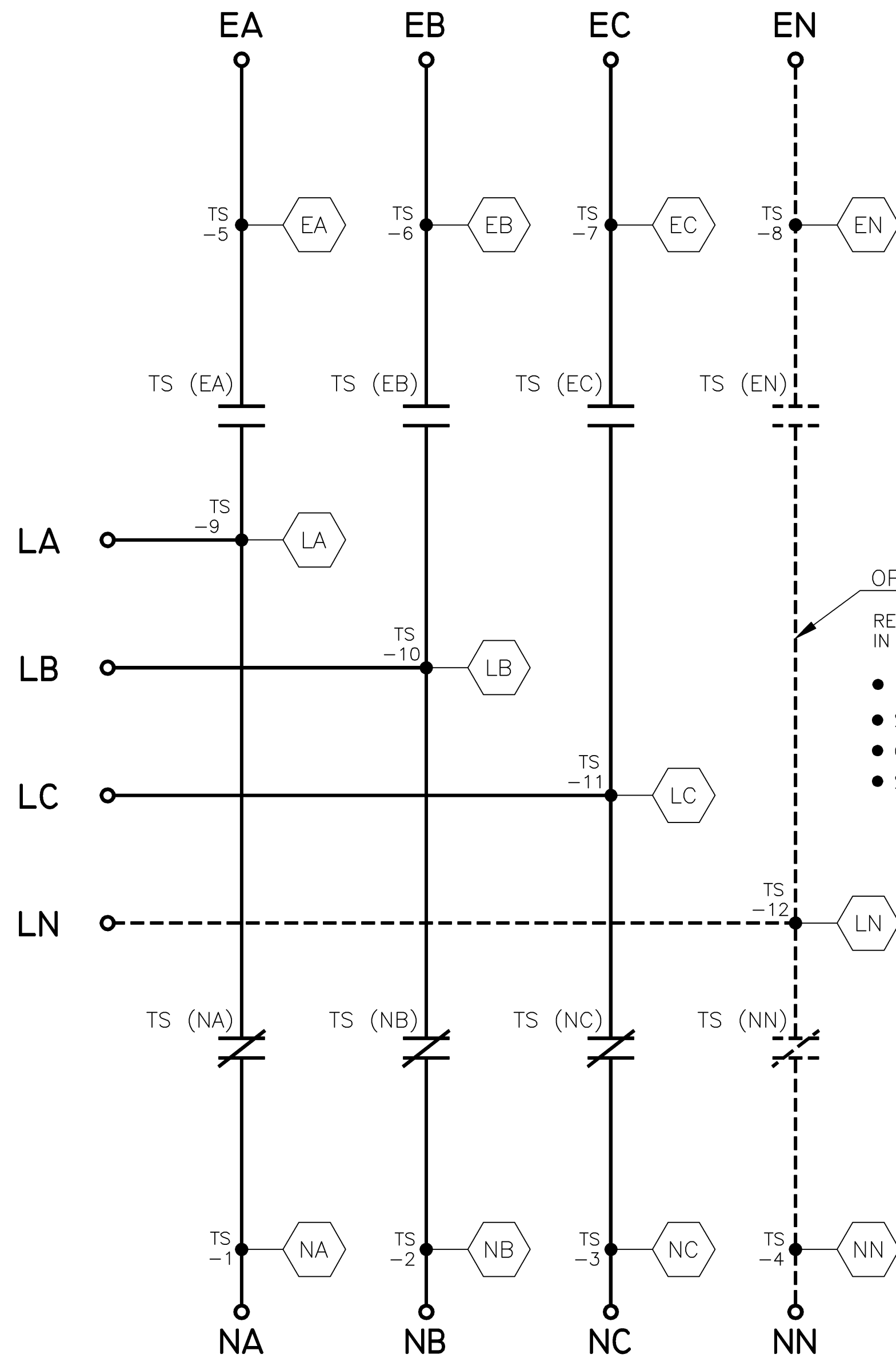

OPTIONAL NEUTRAL TYPES
 REFER TO "EXPLANATION OF CATALOG NUMBER CODES"
 IN CATALOG NUMBER CHART ON SHEET 1.

- NONE
- SWITCHING CONTACTS
- OVERLAPPING CONTACTS
- SOLID BUS PLATE

NOTE:
 ATS SHOWN CLOSED ON NORMAL SOURCE.

NORMAL

EMERGENCY

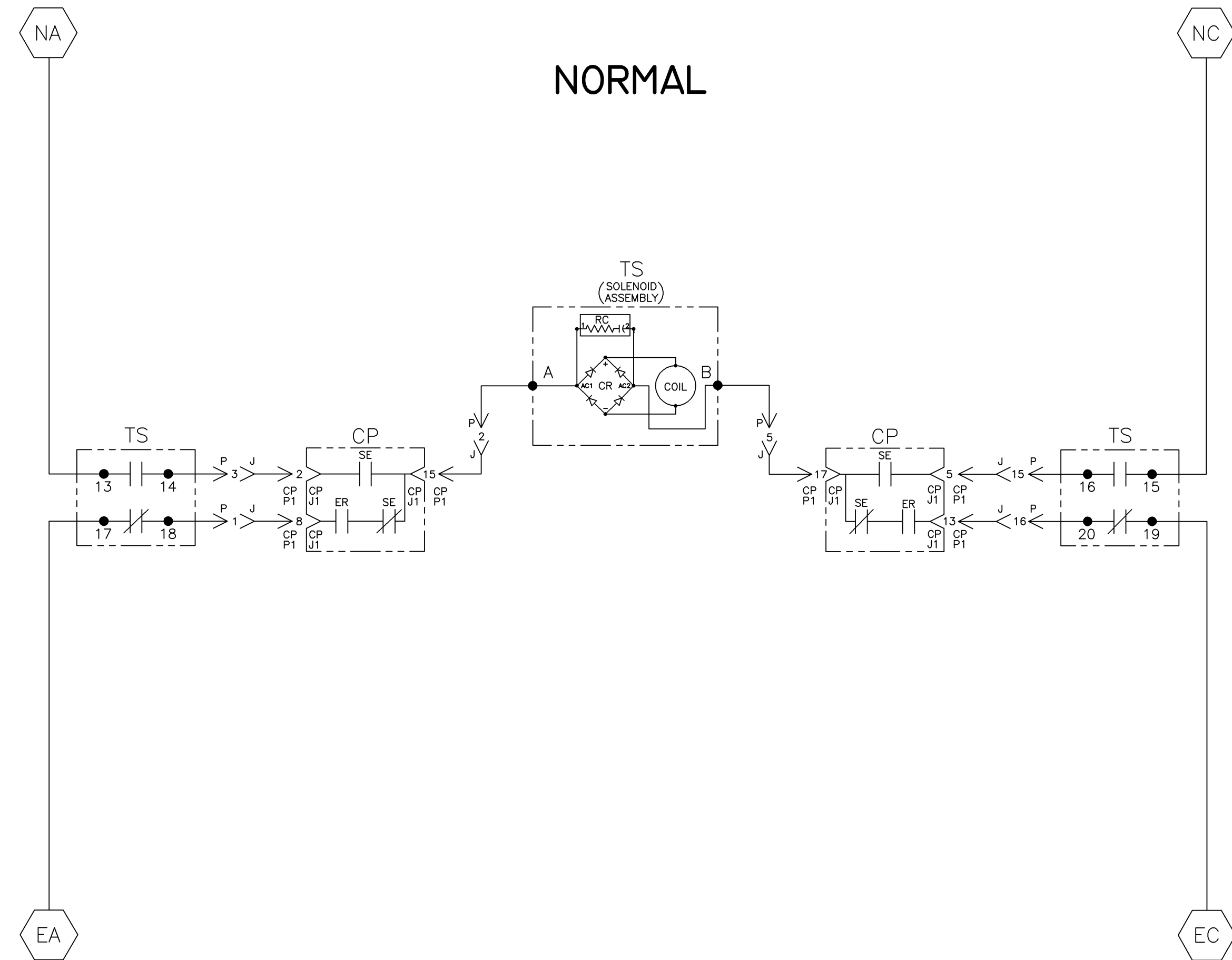

TS CONTROL CONTACTS		SOLENOID POSITION			
TS	CLOSED BEFORE NORMAL	TDC		EMERG	
		>	<	>	<
13-14					
15-16					
17-18					
19-20					

TDC (TOP DEAD CENTER)
 TRANSFER SWITCH TEST & ADJUSTMENT PROCEDURE
 SPECIFIES CONTROL CUT-OFF (CONTACT OPENING)
 SETTING.

PROJECT NAME:		DIAGRAM	
SERIES H300 ATS 3PH 600-1200 AMPS			
"H" FRAME, GROUP 1 CONTROLS			
THIRD ANGLE PROJECTION			

DRAWN BY	BWM	DATE	4/01	PROPERTY OF ASCO POWER TECHNOLOGIES. USE PERMITTED FOR OUR WORK ONLY. ALL RIGHTS OF DESIGN OR INVENTION ARE RESERVED.	ASSEM. REF. NO.	COMPUTER GENERATED DRAWING
CHECKED	BK	DATE	4/10/01			SCALE NONE SIZE DS
PROJECT APPROVAL						DWG. NO. 717501
FINAL APPROVAL	WK	DATE	4/10/01			DRIVING REV. H ECN NO. 234078 SHEET 2 OF 4

H	234078	BK	BK	10/07/11
SEE ECN				
G	213399	WK	BK	05/16/07
SEE ECN				
F	167603	BK	BK	07/22/04
SEE ECN				
E	167217	SDH	SDH	06/04/04
SEE ECN				
D	166704	BWM	WK	03/31/04
SEE ECN				
C	164762	BWM	WK	9/03
ADD 11BG				
B	161046	BWM	SDH	6/02
SEE ECN				
A	157813	BWM	WK	5/24/01
SEE ECN				
-	157352	BWM	WK	4/01
ISSUE				

WIRE RUN LISTING

HARNESS LOCATOR		BOX CHECKED IF HARNESS IS MODIFIED	
WIRE No.	713082 (P) MAIN TS	CLR	AWG
1	P-1,TS-18		16
2	P-2,TS-4		
3	P-3,TS-14		
4	P-4,TS-3		
4	TS-3,TS-15		
5	P-5,TS-B		
6	P-6,TS-7		
6	TS-7,TS-19		
7	P-7,TS-5		
7	TS-5,TS-17		
8	P-8,TS-24		
8	TS-24,TB-1		
9	P-9,TS-25		
9	TS-25,TB-2		
10	P-10,TS-21		
11	P-11,TS-2		
12	P-12,TS-1		
12	TS-1,TS-13		
13	P-13,TS-22		
14	P-14,TS-23		
14	TS-23,TB-3		
16	P-16,TS-20		
17	P-17,TB-3		
18	P-18,TS-6		
19	P-19,TS-9		
20	P-20,TS-10		
21	P-21,TS-11		
22	P-22,TS-4		
23	P-23,TS-8		
24	P-24,TS-12		
25	TS-27,TB-4		
26	TS-28,TB-5		
27	TS-29,TB-6		

HARNESS LOCATOR		BOX CHECKED IF HARNESS IS MODIFIED	
WIRE No.	HARNESS 483763 (J, P1, P2) TS-CP HARNESS	CLR	AWG
1	J-1,CP-P1-8		16
2	J-2,CP-P1-15		
3	J-3,CP-P1-2		
4	J-4,CP-P1-4		
5	J-5,CP-P1-17		
6	J-6,CP-P1-12		
7	J-7,CP-P1-7		
8	J-8,CP-P2-2		
9	J-9,CP-P2-3		
10	J-10,CP-P2-8		
11	J-11,CP-P1-10		
12	J-12,CP-P1-1		
13	J-13,CP-P2-9		
14	J-14,CP-P2-10		
15	J-15,CP-P1-5		
16	J-16,CP-P1-13		
17	J-17,CP-P2-1		
18	J-18,CP-P1-14		

HARNESS LOCATOR		OPTIONAL ACC. 11BG CKTS.	
WIRE No.	OPTIONAL ACC. 11BG CKTS.	CLR	AWG
28	CP-TB-4,11BG-TB-9		16

HARNESS LOCATOR		OPTIONAL ACC. 14AA & 14BA	
WIRE No.	OPTIONAL ACC. 14AA & 14BA	CLR	AWG
32	TS-30,TB-7		16
33	TS-31,TB-8		
34	TS-32,TB-9		

CONTROL SIGNALS & INDICATION

ACCESSORY 11BG PROGRAMMABLE ENGINE EXERCISER & SOURCE AVAILABILITY SIGNAL (OPTIONAL)

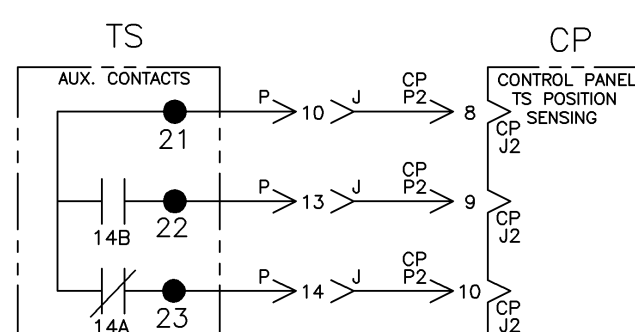
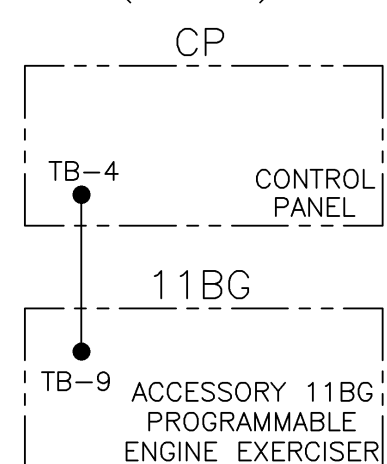

EMERGENCY SOURCE CIRCUITS

EMERGENCY

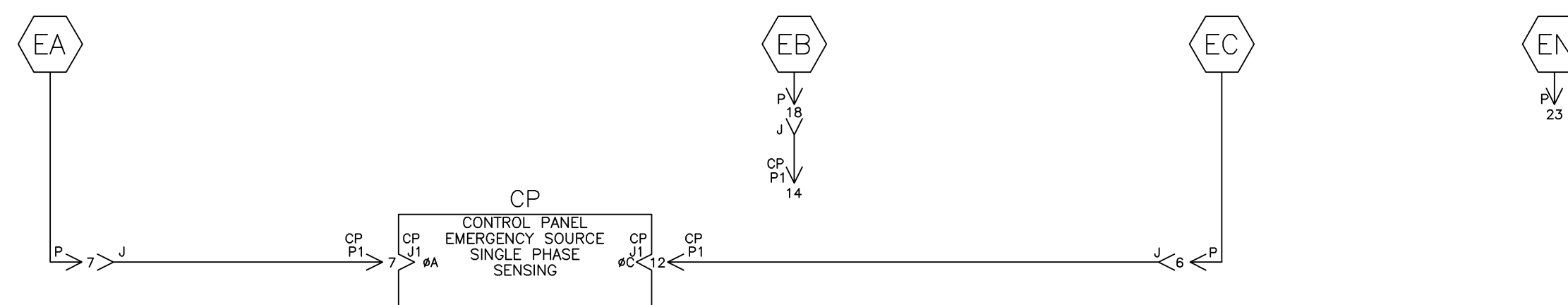

LOAD TERMINAL CIRCUITS

LOAD



NORMAL SOURCE CIRCUITS

NORMAL

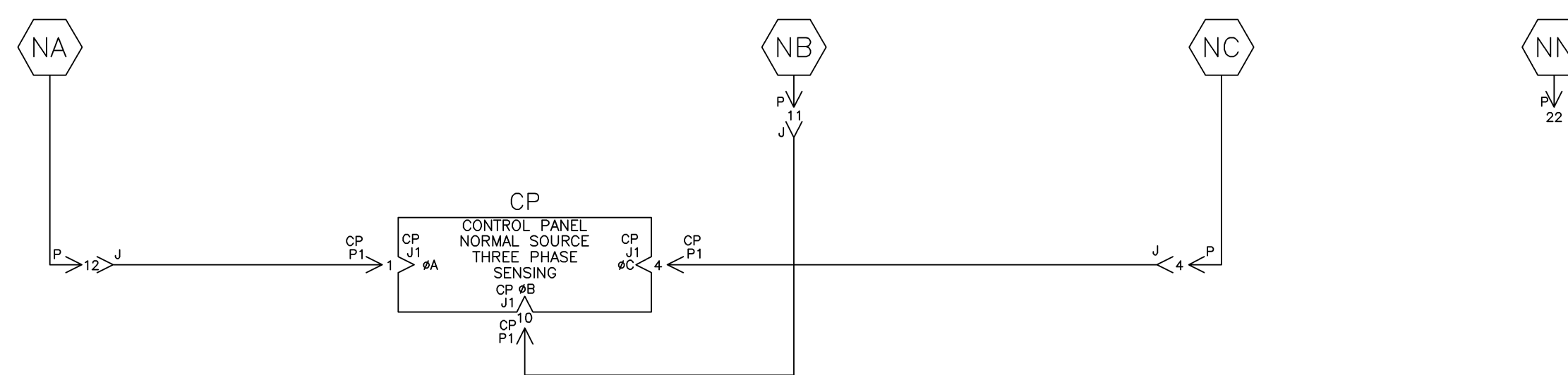

H	234078	BK	BK	10/07/11
SEE ECN				
G	213399	WK	BK	05/16/07
SEE ECN				
F	167603	BK	BK	07/22/04
SEE ECN				
E	167217	SDH	SDH	06/04/04
SEE ECN				
D	166704	BWM	WK	03/31/04
SEE ECN				
C	164762	BWM	WK	9/03
ADD 11BG				
B	161046	BWM	SDH	6/02
SEE ECN				
A	157813	BWM	WK	5/24/01
SEE ECN				
-	157352	BWM	WK	4/01
ISSUE				

PROJECT NAME: _____

WIRING DIAGRAM

SERIES H300 ATS 3PH 600-1200 AMP'S

"H" FRAME, GROUP 1 CONTROLS

THIRD ANGLE PROJECTION

DRAWN BY	BWM	DATE	4/01	MANUFACTURING TOLERANCES TO BE IN ACCORDANCE WITH ASCO PROCEDURE MP-1-003. FOR PLASTIC PARTS SEE MP-1-005.	ASSEM. REF. NO.	COMPUTER GENERATED DRAWING
CHECKED BY	BK	DATE	4/10/01	PROPERTY OF ASCO POWER TECHNOLOGIES. USE PERMITTED FOR OUR WORK ONLY. ALL RIGHTS OF DESIGN OR INVENTION ARE RESERVED.	DWG. NO.	717501
PROJECT APPROVAL					SCALE	NONE
FINAL APPROVAL	WK	DATE	4/10/01		SIZE	DS
					DWG. NO.	717501
					DRAWING REV.	H
					ECN NO.	234078
					SHEET	3 OF 4

ASCO POWER TECHNOLOGIES, L.P.
FLORHAM PARK, NEW JERSEY 07832 U.S.A.

PHYSICAL DIAGRAM

ENCLOSURE

DOOR (INSIDE)

TS (TRANSFER SWITCH)
VIEW FROM INSIDE FRONT

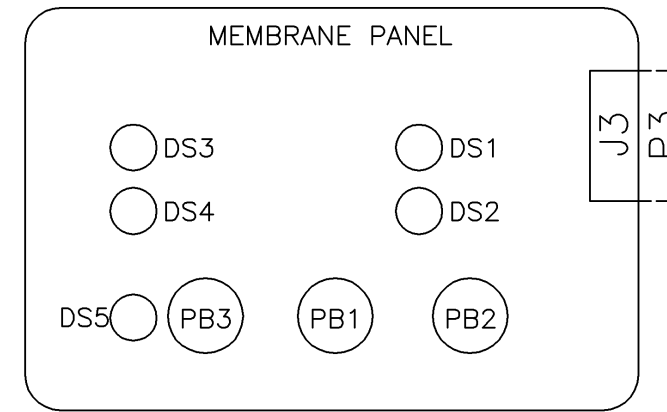
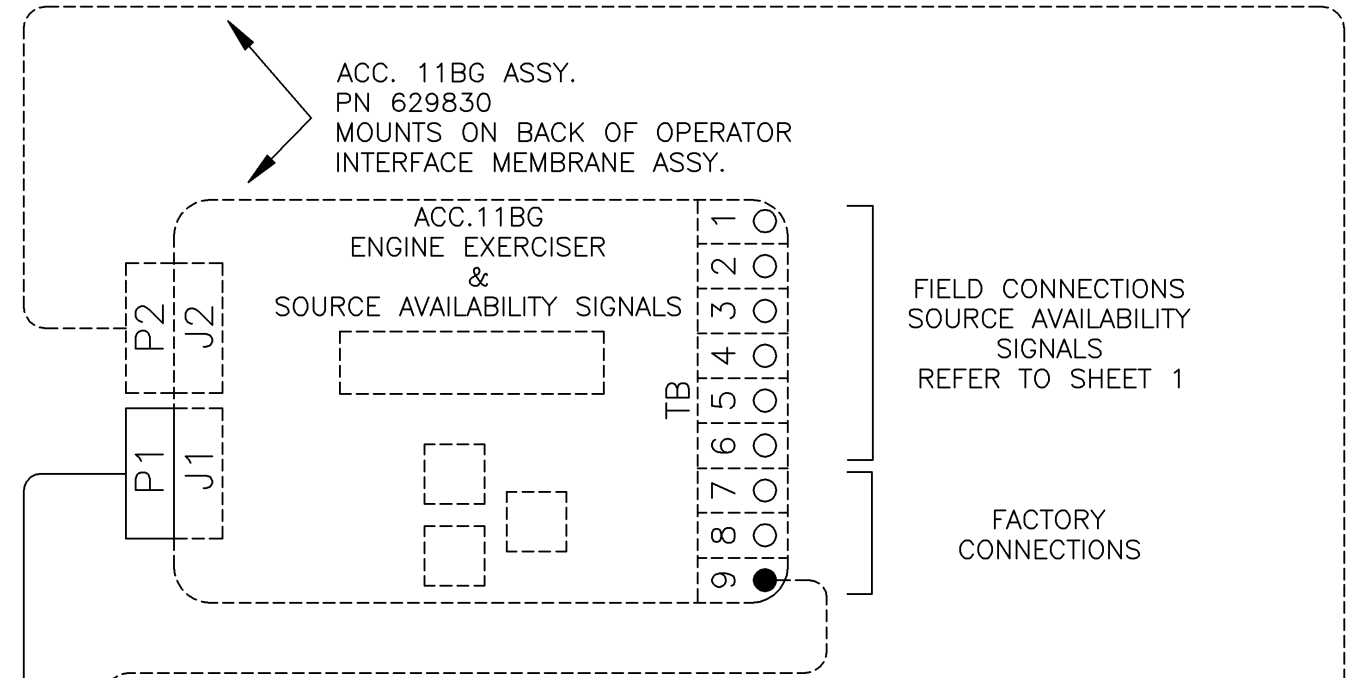
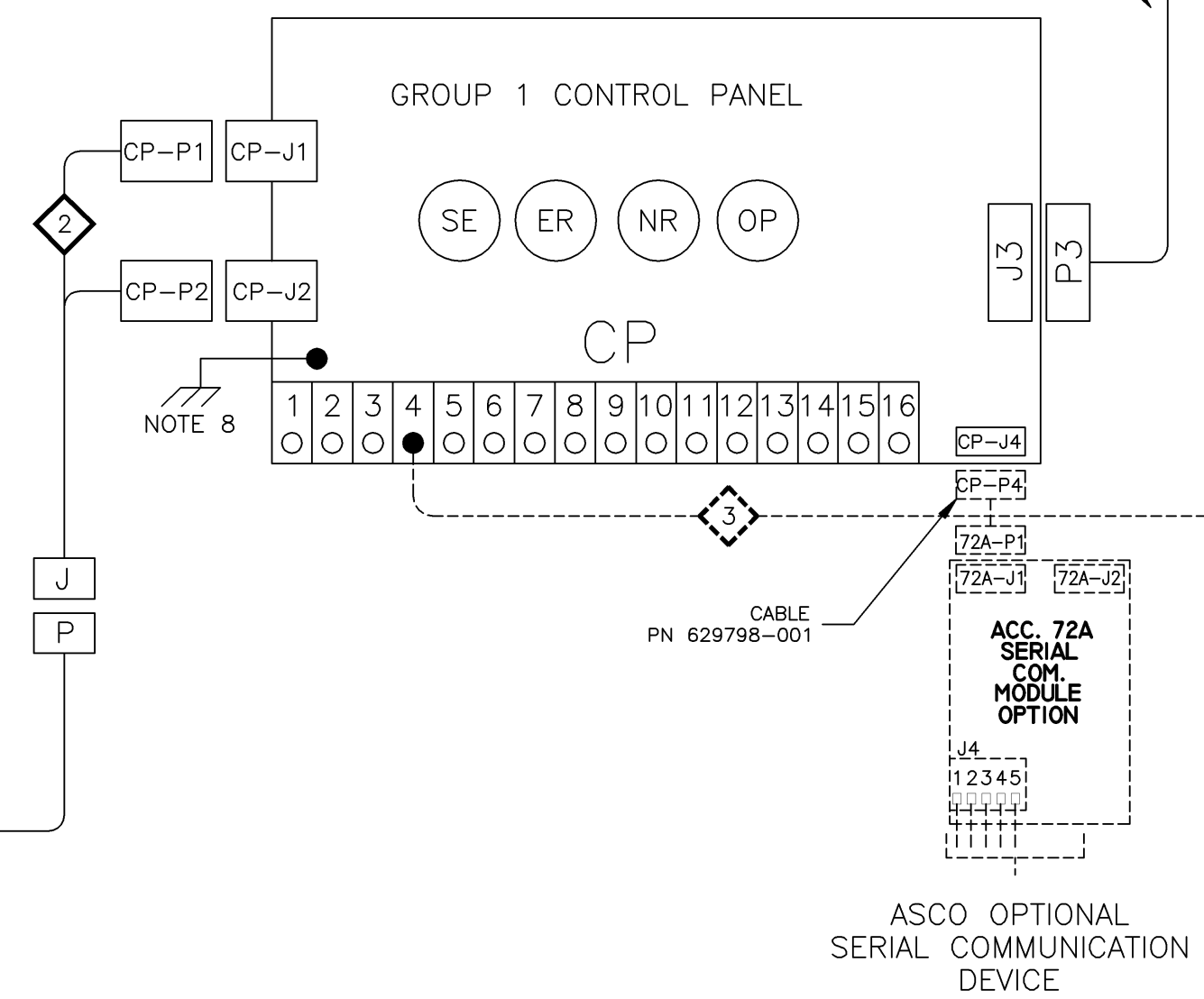
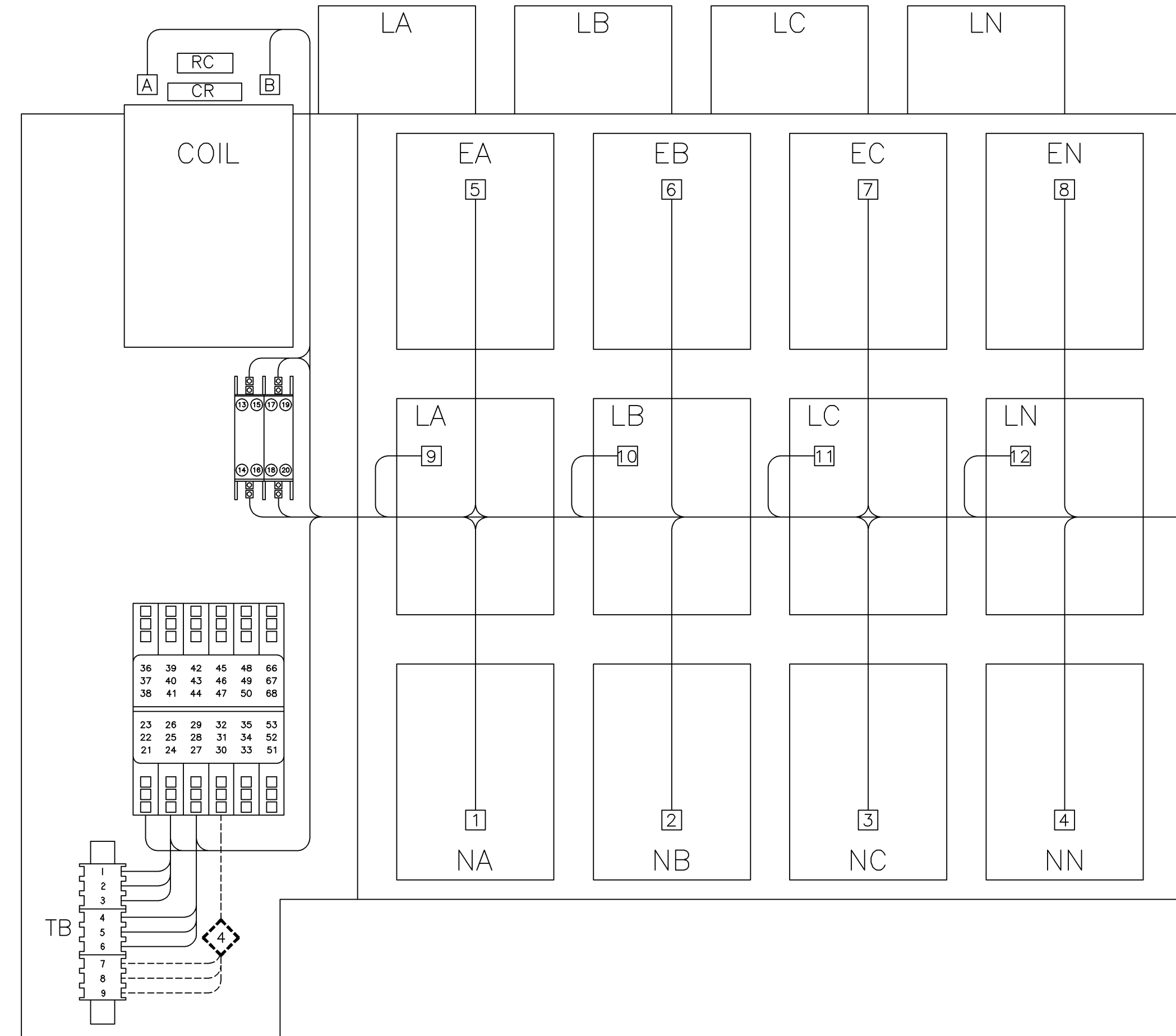

OPERATOR CONTROLS

ID	DESCRIPTION
DS1	TS CONNECTED TO NORMAL
DS2	TS CONNECTED TO EMERGENCY
DS3	NORMAL SOURCE AVAILABLE
DS4	EMERGENCY SOURCE AVAILABLE
DS5	ENGINE EXERCISER
PB1	BYPASS TIME DELAY
PB2	TRANSFER SWITCH TEST
PB3	SET ENGINE EXERCISER

TO LOAD OF ATS
(OPTIONAL ACC. 44G)
OR
TO CUSTOMER POWER
SUPPLY 120VAC
(OPTIONAL ACC. 44A)

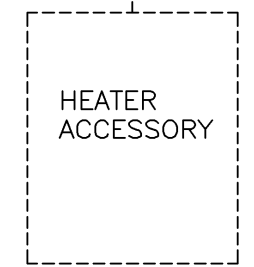

DOOR HINGE

BONDING STRAP
PN 098323-019

H	234078	BK	BK	10/07/11
	SEE ECN			
G	213399	WK	BK	05/16/07
	SEE ECN			
F	167603	BK	BK	07/22/04
	SEE ECN			
E	167217	SDH	SDH	06/04/04
	SEE ECN			
D	166704	BWM	WK	03/31/04
	SEE ECN			
C	164762	BWM	WK	9/03
	ADD 11BG			
B	161046	BWM	SDH	6/02
	SEE ECN			
A	157813	BWM	WK	5/24/01
	SEE ECN			
	157352	BWM	WK	4/01
	ISSUE			

PROJECT NAME: **WIRING DIAGRAM**

SERIES H300 ATS 3PH 600-1200 AMPS
"H" FRAME, GROUP 1 CONTROLS

REV TO SHEET	ECN NO.	BY	APP.	DATE

THIRD ANGLE PROJECTION

DRAWN BY	DATE	CHECKED BY	DATE	PROJECT APPROVAL	FINAL APPROVAL
BWM	4/01	BK	4/10/01		WK

ASCO POWER TECHNOLOGIES, L.P.
FLORHAM PARK, NEW JERSEY 07832 U.S.A.

COMPUTER GENERATED DRAWING
SCALE: NONE SIZE: DS
DWG. NO.: 717501
DRAWING REV. H ECN NO. 234078 SHEET 4 OF 4