

# DSEULTRA® STARTING WITH QUALITY.

## DSE704 & DSE4120 AUTO MAINS FAILURE CONTROL MODULES



### SPECIFICATION

#### DC SUPPLY

8V to 35V continuous

#### CRANKING DROPOUTS

Able to survive 0V for 50mS, providing supply was at least 10V before dropout and supply recovers to 5V. This is achieved without the need for internal batteries.

#### MAXIMUM OPERATING CURRENT

170mA(12V), 280mA(24V) (DSE4120 only)  
50mA (DSE704 only)

#### TYPICAL CURRENT

35mA(12V and 24V) (DSE 4120 only)  
12mA (704 only)

#### ALTERNATOR INPUT RANGE

75V(L-N) to 333V AC (L-N) absolute maximum

#### ALTERNATOR INPUT FREQUENCY

50Hz – 60Hz at rated engine speed  
(minimum:75V AC L-N) (Crank disconnect from 15V L-N @ 20Hz) Overspeed +14% (+24% overshoot) Underspeed -20%

#### START & FUEL OUTPUTS

1.2 Amp DC at supply voltage. Switches to battery negative when active

#### AUXILIARY OUTPUTS

1.2 Amp DC at supply voltage. Switches to battery negative when active

#### DSE704 DIMENSIONS

165mm x 125mm x 29mm  
6.5" x 4.9" x 1.2"

#### DSE704 CUT OUT

149mm X 109mm  
5.9" x 4.3"

#### DSE4120 DIMENSIONS

171mm x 115mm x 49mm  
6.7" x 4.5" x 1.9"

#### DSE4120 PANEL CUT OUT

154mm x 98mm  
6.1" x 3.9"

#### CHARGE FAIL

8 Volt Charge Fail at 12 Volts, 16 Volt Charge Fail at 24 Volts

### ENVIRONMENTAL TESTING STANDARDS

#### ELECTRO MAGNETIC CAPABILITY

BS EN 61000-6-2  
EMC Generic Emission Standard for the Industrial Environment  
BS EN 61000-6-4  
EMC Generic Emission Standard for the Industrial Environment

#### TEMPERATURE

BS EN 60068-2-2  
Test Ab to +70°C 60067-2-2 Hot  
Test Ab to -30°C 60068-2-1 Cold

#### VIBRATION

BS EN 60068-2-6  
Ten sweeps in each of three major axes  
5Hz to 8Hz @ +/-7.5mm, 8Hz to 500Hz @ 2gn

#### HUMIDITY

BS 2011 part 2.1 60068-2-30  
Test Cb Ob Cyclic  
93% RH @ 40°C for 48 hours

#### SHOCK

BS EN 60068-2-27  
Three shocks in each of three major axes  
15gn in 11ms

DSE704

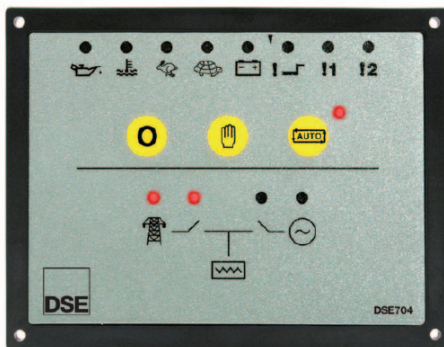

The DSE704 is an Auto Mains Failure Control Module that offers an excellent range of engine monitoring and protection features. The module has been designed to monitor engine temperature, low oil pressure, fail to start, charge failure, over speed and under speed.

When the module detects a fault condition it automatically shuts down the engine. The module also includes two user configurable auxiliary inputs.

The DSE4120 module includes all the features of the DSE704 plus a tamper proof engine hours counter, engine exercise mode function and the enclosure has a closed back.

Both modules have been designed to automatically start the generator when the mains (utility) power fails. As soon as mains (utility) power is restored the modules have been designed to transfer the load back to the mains (utility) supply. The modules then instruct the engine to begin the cool down procedure and stopping sequence (user configured).

DSE4120

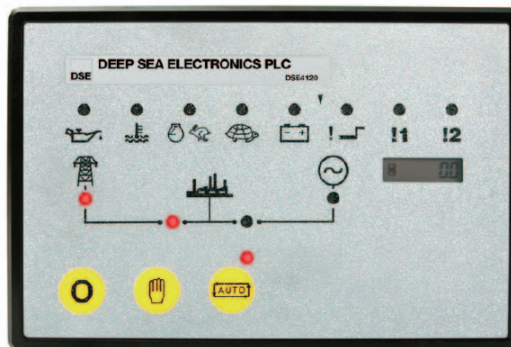

### FEATURES

- Automatic mains (utility) supply monitoring
- Automatic shutdown when fault conditions are detected
- Manual start
- Engine pre-heat
- Engine monitoring and protection features
- Protected Solid State (PSS) outputs
- Front panel mounting
- Front panel programming
- Tamper proof engine hours counter
- Remote start
- LED indicators
- Configurable timers
- Configurable outputs
- Single/three phase mains sensing

### BENEFITS

- Transfers between mains (utility) and generator power
- On-site module configuration to match user requirements
- Hours counter provides accurate information for monitoring maintenance and warranty periods
- Multiple engine parameters are monitored simultaneously

### OPERATION

The modules are operated using the three push buttons on the front:



**MANUAL** – This mode is used to manually start the engine.



**AUTO** – This mode is used to automatically start the engine. The module will be started by the remote start signal.



**STOP** – This button is used to stop the engine when it is running in either manual or automatic mode.



# DSE704 & DSE4120

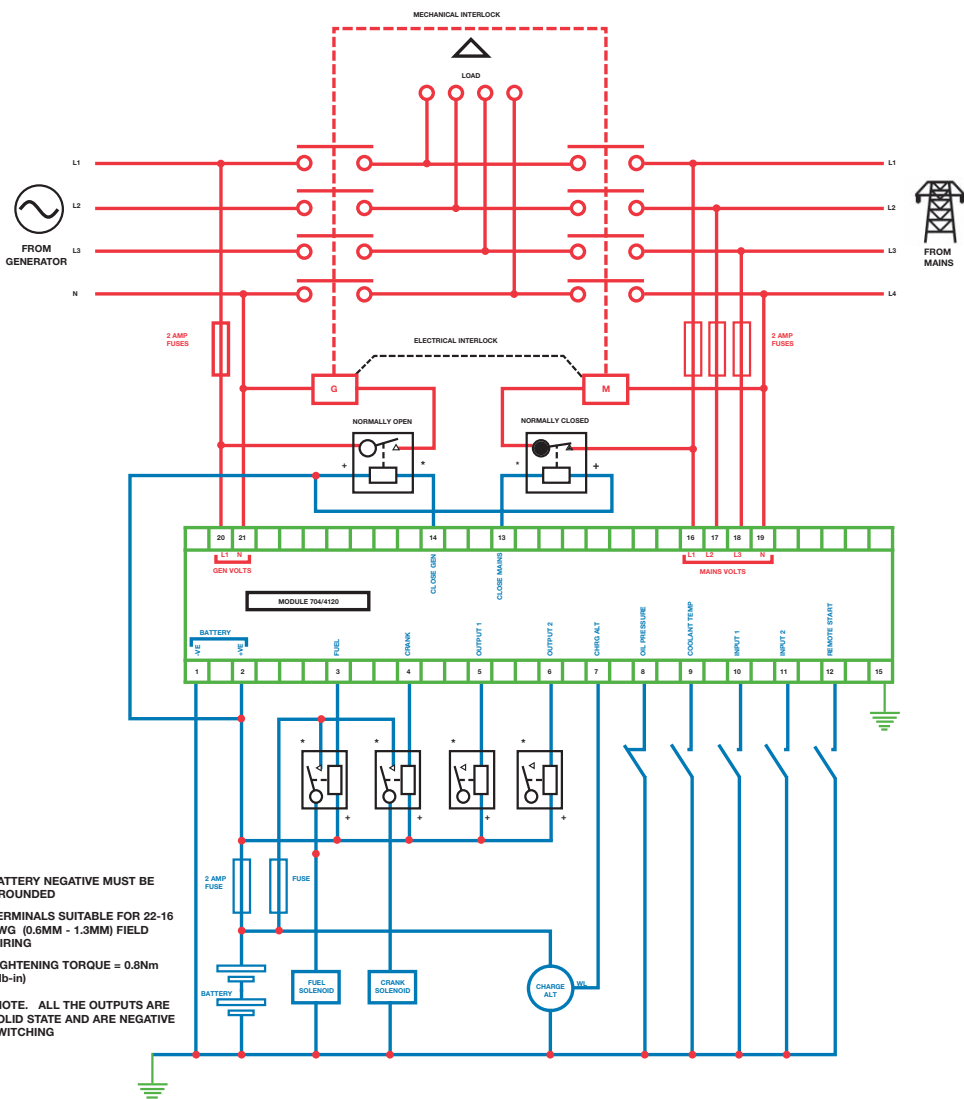

BATTERY NEGATIVE MUST BE GROUNDED  
 TERMINALS SUITABLE FOR 22-16 AWG (0.6MM - 1.3MM) FIELD WIRING  
 TIGHTENING TORQUE = 0.8Nm (7lb-in)  
 \*NOTE. ALL THE OUTPUTS ARE SOLID STATE AND ARE NEGATIVE SWITCHING

### CONFIGURATION

The modules can be configured to match user's individual parameter settings. Configuration mode is accessed via the switch at the rear of the module. Once in configuration mode the **AUTO-LED** (AUTO) flashes rapidly.

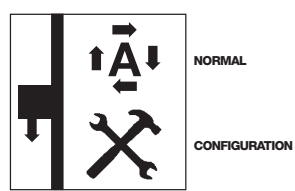

Please refer to the installation instructions for the parameter settings and configuration details.

### RELATED MATERIALS

TITLE	PART NO'S
DSE704 Installation Instructions	053-036
DSE704 Operators Manual	057-043
DSE4120 Installation Instructions	053-021
DSE4120 Operators Manual	057-023

DEEP SEA ELECTRONICS PLC maintains a policy of continuous development and reserves the right to change the details shown on this data sheet without prior notice. The contents are intended for guidance only.

This data sheet is printed on 90gsm 55 Silk, which is produced with 55% recycled fibre from both pre and post-consumer sources, together with 45% virgin ECF fibre.

