

**COMPLEX SOLUTIONS
MADE SIMPLE**



DSEPOWER[®]

DEEP SEA ELECTRONICS PLC

**DSE5510
AUTOSTART CONTROL MODULE**

OPERATING MANUAL



Deep Sea Electronics Plc
Highfield House
Hunmanby
North Yorkshire
YO14 0PH
ENGLAND

Sales Tel: +44 (0) 1723 890099
Sales Fax: +44 (0) 1723 893303

E-mail: sales@Deepseapl.com
Website: www.deepseapl.com

DSE Model 5510 Control and Instrumentation System Operators Manual

© Deep Sea Electronics Plc

All rights reserved. No part of this publication may be reproduced in any material form (including photocopying or storing in any medium by electronic means or other) without the written permission of the copyright holder except in accordance with the provisions of the Copyright, Designs and Patents Act 1988.

Applications for the copyright holder's written permission to reproduce any part of this publication should be addressed to Deep Sea Electronics Plc at the address above.

Any reference to trademarked product names used within this publication is owned by their respective companies.

Deep Sea Electronics Plc reserves the right to change the contents of this document without prior notice.

1 BIBLIOGRAPHY

1. IEEE Std C37.2-1996 IEEE Standard Electrical Power System Device Function Numbers and Contact Designations. Institute of Electrical and Electronics Engineers Inc. ISBN 1-55937-879-4
2. Diesel generator handbook. L.L.J.Mahon. ISBN 0-7506-1147-2
3. On-Site Power Generation. EGSA Education Committee. ISBN 0-9625949-3-8

TABLE OF CONTENTS

Section	Page
1 BIBLIOGRAPHY.....	2
2 INTRODUCTION.....	5
2.1 CLARIFICATION OF NOTATION USED WITHIN THIS PUBLICATION.	6
2.2 ICON DESCRIPTIONS.....	6
3 OPERATION.....	7
3.1 CONTROL.....	7
3.2 AUTOMATIC MODE OF OPERATION.....	8
3.3 MANUAL OPERATION.....	11
4 PROTECTIONS.....	13
4.1 WARNINGS.....	15
4.2 ANALOGUE PRE-ALARMS.....	19
4.3 SHUTDOWNS.....	21
4.4 ELECTRICAL TRIPS.....	27
4.5 ROCOF / VECTOR SHIFT.....	30
5 DESCRIPTION OF CONTROLS.....	31
5.1 TYPICAL LCD DISPLAY SCREENS.....	31
5.1.1 TYPICAL STATUS DISPLAY.....	31
5.1.2 TYPICAL INSTRUMENT DISPLAY.....	32
5.1.3 TYPICAL ALARM DISPLAY.....	32
5.1.4 TYPICAL EVENT DISPLAY.....	33
5.2 VIEWING THE INSTRUMENT AND EVENT LOG PAGES.....	34
5.2.1 SYNCHROSCOPE OPERATION.....	35
5.3 COMPLETE INSTRUMENTATION LIST.....	36
5.3.1 BASIC INSTRUMENTATION.....	36
5.3.2 ENHANCED ENGINE INSTRUMENTATION.....	36
5.4 ACCESSING THE FRONT PANEL CONFIGURATION EDITOR.....	37
5.4.1 ENTERING THE CONFIGURATION EDITOR PIN NUMBER.....	37
5.4.2 EDITING VALUES.....	38
5.4.3 LIST OF ADJUSTABLE PARAMETERS IN 'MAIN CONFIGURATION EDITOR'.....	39
5.4.4 LIST OF ADJUSTABLE PARAMETERS IN 'APPLICATION EDITOR'.....	40
5.4.5 DISPLAY EDITOR.....	41
5.4.6 EDITING 'DISPLAY EDITOR' CONFIGURATION VALUES.....	41
6 LED INDICATORS AND LOGO INSERT.....	43
6.1 LED IDENTIFICATION AND FRONT PANEL LAYOUT.....	44
7 CONTROL PUSH-BUTTONS.....	44
8 INSTALLATION INSTRUCTIONS.....	47
8.1 PANEL CUT-OUT.....	47
8.2 COOLING.....	47
8.3 UNIT DIMENSIONS.....	47
9 ELECTRICAL CONNECTIONS.....	48
9.1 CONNECTION DETAILS.....	48
9.1.1 PLUG "A" 8 WAY.....	48
9.1.2 PLUG "B" 11 WAY.....	48
9.1.3 PLUG "C" 9 WAY.....	49
9.1.4 PLUG "D" 3 WAY.....	49
9.1.5 PLUG "E" 5 WAY.....	49
9.1.6 PLUG "F" 8 WAY.....	50
9.1.7 PLUG "G" 4 WAY.....	50

9.1.8	PLUG "H" 12 WAY.....	51
9.1.9	PC CONFIGURATION INTERFACE CONNECTOR.....	51
9.1.10	EXPANSION INTERFACE CONNECTOR.....	51
9.2	CONNECTOR FUNCTION DETAILS.....	52
9.2.1	PLUG "A" 8 WAY.....	52
9.2.2	PLUG "B" 11 WAY.....	52
9.2.3	PLUG "C" 9 WAY.....	53
9.2.4	PLUG "D" 3 WAY.....	53
9.2.5	PLUG "E" 5 WAY.....	53
9.2.6	PLUG "F" 8 WAY.....	54
9.2.7	PLUG "G" 4 WAY.....	54
9.2.8	PLUG "H" 12 WAY.....	54
9.3	ENGINE CONTROL UNIT INTERFACE.....	55
10	SPECIFICATION.....	56
11	COMMISSIONING.....	58
11.1	BYPASSING ALARMS AT STARTUP.....	59
11.2	COMMISSIONING SCREENS.....	59
11.2.1	SCREEN 1.....	59
11.2.2	SCREEN 2.....	59
12	FAULT FINDING.....	60
13	TYPICAL WIRING DIAGRAM.....	61
13.1	CONNECTIONS FOR 3 CT SYSTEM.....	61
13.2	CONNECTIONS FOR 4 CT SYSTEM.....	62
14	FACTORY DEFAULT CONFIGURATION.....	63
15	SENDER WIRING RECOMMENDATIONS.....	67
15.1	USING EARTH RETURN (SINGLE WIRE) SENDERS.....	67
15.2	USING INSULATED RETURN (TWO WIRE) SENDERS.....	67
16	APPENDIX.....	68
16.1	5510 IDMT TRIPPING CURVES (TYPICAL).....	68
16.2	5510 SHORT CIRCUIT TRIPPING CURVES (TYPICAL).....	68
16.3	ACCESSORIES.....	69
16.3.1	OUTPUT EXPANSION.....	69
	RELAY OUTPUT EXPANSION (157).....	69
	LED OUTPUT EXPANSION (548).....	69
16.3.2	INPUT EXPANSION (P130/P540/P541).....	69
16.4	COMMUNICATIONS OPTION.....	70
16.4.1	DESCRIPTION.....	70
16.4.2	PC TO CONTROLLER (DIRECT) CONNECTION.....	70
16.4.3	MODEM TO CONTROLLER CONNECTION.....	70
16.4.4	RS485 LINK TO CONTROLLER.....	71
	TYPICAL BUILDING MANAGEMENT SCHEME USING RS485 MONITORING.....	72
16.4.5	MODBUS™.....	72
16.5	ENCLOSURE CLASSIFICATIONS.....	73
	IP CLASSIFICATIONS.....	73
	NEMA CLASSIFICATIONS.....	74
16.6	IEEE C37.2 STANDARD ELECTRICAL POWER SYSTEM DEVICE FUNCTION NUMBERS.....	75
16.7	SYNCHRONISING NOTES.....	77
16.7.1	CHECK SYNC.....	77
16.7.2	AUTO SYNC.....	77
16.7.3	LOAD CONTROL.....	77
16.7.4	TYPICAL LOAD SHARING SYSTEM.....	78
16.7.5	TYPICAL PEAK SHAVING SYSTEM.....	78

2 INTRODUCTION

The **DSE 5510** Module allows the OEM to meet demand for increased capability within the industry. It allows the user to start and stop the generator and if required, transfer the load to the generator either manually or automatically. The user also has the facility to view the system operating parameters via the LCD display.

Utilising the inbuilt synchronising, volts matching and paralleling functions, the controller is able to parallel with the mains supply for simple peak lopping (fixed generator output). Alternatively, the 5510 can be used to parallel with other DSE 5510 load sharing controllers. Up to 16 sets can be connected in paralleling and load share as a standalone (prime power) system. Additionally they can parallel with the mains supply (when used in conjunction with DSE 5560).

The **DSE 5510** module also monitors the engine, indicating the operational status and fault conditions, automatically shutting down the engine. Exact failure mode information is indicated by the LCD display on the front panel.

The powerful Microprocessor contained within the module allows for many features to be incorporated as standard;





- *Full Multilingual LCD display (including non-western character fonts).*
- *True R.M.S. voltage monitoring.*
- *Power measurement.*
- *Communications capability (RS485 or RS232 including GSM/SMS functions)*
- *Check Sync capability*
- *Automatic Sync capability*
- *Load share / control capability*
- *Fully configurable inputs for use as alarms or a range of different functions also available on P130 expansion inputs (optional)*
- *Extensive range of output functions using built in relay outputs or relay expansion available.*
- *Instrumentation and diagnostics from electronic engines when connected to an engine ECU.*

Selective operational sequences, timers and alarm trips can be altered by the customer via a PC using the 5xxx For Windows™ software and 810 interface or via the integral front panel configuration editor.













Access to critical operational sequences and timers for use by qualified engineers, can be protected by a security code. Module access can also be protected by PIN code. Selected parameters can be changed from the module's front panel.

The module is housed in a robust plastic case suitable for panel mounting. Connections to the module are via locking plug and sockets.

2.1 CLARIFICATION OF NOTATION USED WITHIN THIS PUBLICATION.

	NOTE:	Highlights an essential element of a procedure to ensure correctness.
	CAUTION!:	Indicates a procedure or practice which, if not strictly observed, could result in damage or destruction of equipment.
	WARNING!:	Indicates a procedure or practice which could result in injury to personnel or loss of life if not followed correctly.
		Deep Sea Electronics Plc owns the copyright to this manual, which cannot be copied, reproduced or disclosed to a third party without prior written permission.

2.2 ICON DESCRIPTIONS

Symbol	Meaning	Description
	Stop/Reset	Stop the generator and reset any alarm conditions.
	Start	Start the generator (if in an appropriate mode).
	Auto	The controller will automatically start the generator when given a remote start command.
	Manual	The controller will start the generator under manual control. <i>(Separate Start command may be necessary)</i>
	Alarm Mute and lamp test	Silences the audible warning device and illuminates all LEDs to provide lamp test functionality.
	Information	Changes the display to another page
	Up	Selects the previous item on the page
	Down	Selects the next item on the page
	Open generator	Open generator load switching device (manual mode only)
	Close generator	Close generator load switching device (manual mode only)
	Accept	Edit or save current selection (configuration mode only)
	Increase	Increase current selection (configuration mode only)
	Decrease	Decrease current selection (configuration mode only)

3 OPERATION

3.1 CONTROL

Control of the **DSE 5510** module is via push buttons mounted on the front of the module with **STOP/RESET, MANUAL, AUTO, ALARM MUTE/LAMP TEST** and **START** functions. For normal operation these are the only controls which need to be operated. The smaller push buttons are used to access further information such as engine instruments and load switching. Detail of their operation is covered later in this document.

The following descriptions detail the sequences followed by a module containing the standard 'factory configuration'. Always refer to your configuration source for the exact sequences and timers observed by any particular module in the field.

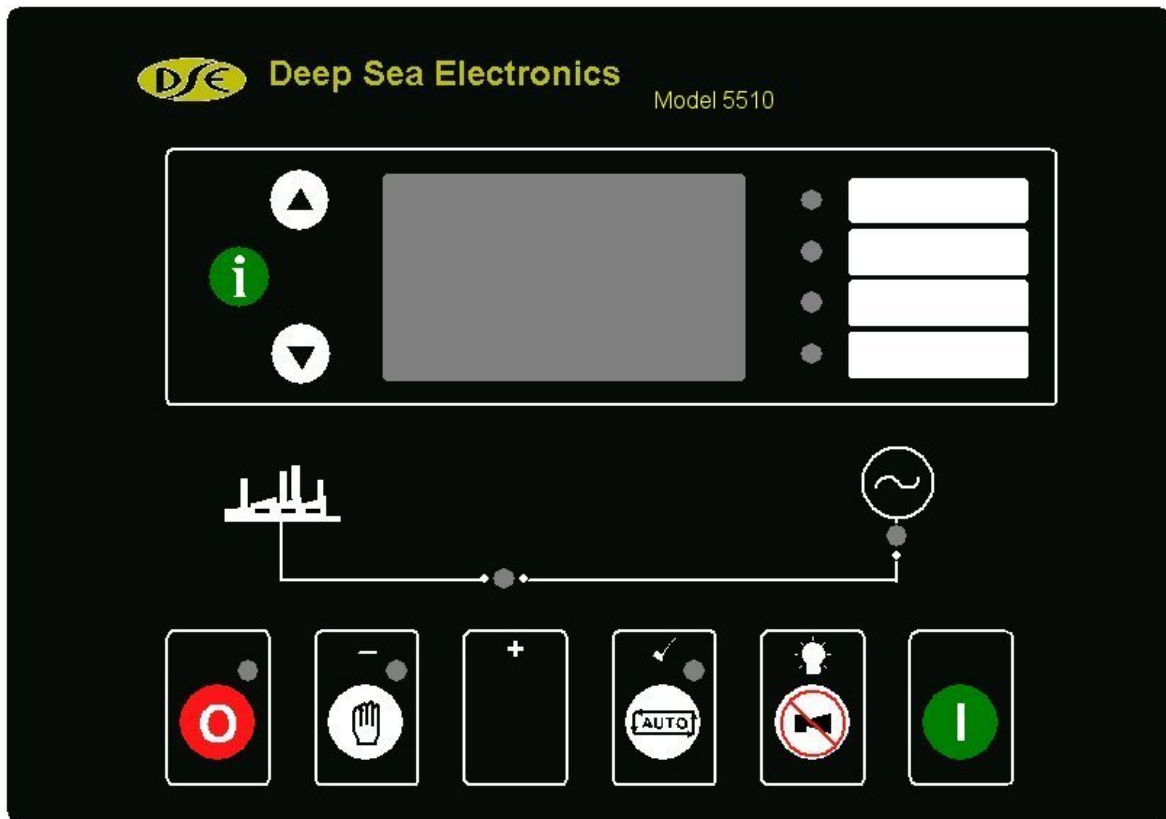



 **CAUTION:** - The module may instruct an engine start event due to external influences. Therefore, it is possible for the engine to start at any time without warning. Prior to performing any maintenance on the system, it is recommended that steps are taken to remove the battery and isolate supplies.

3.2 AUTOMATIC MODE OF OPERATION

Automatic mode is used to start the set in response to an external start requirement from another device.

A number of options exist for the remote start input (selectable using 5xxx configuration software).

- Remote Start on Load input indicates to the controller that it should start the set, and run 'off load'.
- Remote Start on Load input indicates to the controller that it should start the set, synchronise (if required) and share load with any other sets in the system.
- Remote Start on Load Demand input indicates to the controller that it should start the sets, synchronise (if required) and share load with any other sets in the system, automatically starting and stopping sets on changing load demand.

 **NOTE:** - If a digital input configured to panel lock is active, changing module modes will not be possible. Viewing the instruments  and  is NOT affected by panel lock. If panel lock is active the Panel lock indicator (if configured) illuminates.

This mode is activated by pressing the  pushbutton. An LED indicator beside the button will illuminate to confirm this operation.

Should the remote start input (if configured) become active then the following sequence is observed.

To allow for short term or false remote start signals, the Start Delay timer is initiated. After this delay, if the pre-heat output option is selected then the pre-heat timer is initiated and the corresponding auxiliary output (if configured) will energise.

 **NOTE:-** If the Remote Start signal is removed during the Start Delay timer, the unit will return to a stand-by state.

After the above delays the **Fuel Solenoid (or enable ECU output if configured)** is energised, then one second later, the **Starter Motor** is engaged.

 **NOTE:-** If the unit has been configured for CAN Bus, compatible ECU's will receive the start command via CAN Bus. Refer to the Manual CAN and DSE Wiring. Part No. 057-004 for more information on utilising DSE modules with electronically controlled engines.

The engine is cranked for a pre-set time. If the engine fails to fire during this cranking attempt then the starter motor is disengaged for the pre-set rest period. Should this sequence continue beyond the set number of attempts, the start sequence will be terminated and **Fail to Start** fault will be displayed.

Alarm

**Shutdown
Failed to start**

When the engine fires, the starter motor is disengaged and locked out at a pre-set frequency measured from the alternator output. Alternatively, a Magnetic Pickup mounted on the flywheel housing can be used for speed detection (This is selected by PC using the 5xxx series configuration software). Rising oil pressure can also be used to disconnect the starter motor, however it cannot be used for underspeed or overspeed detection.

 **NOTE:- If the unit has been configured for use with an electronic engine, speed sensing is via the data-link.**

After the starter motor has disengaged, the **Safety On** timer is activated, allowing Oil Pressure, High Engine Temperature, Under-speed, Charge Fail and any delayed Auxiliary fault inputs to stabilise without triggering the fault.

If the system has been started by a '**remote start off load**' input, the set will run '**off load**'. Otherwise, the **Warm Up** timer, if selected, is initiated, allowing the engine to stabilise. After the **Warm-up** timer has expired then the module will close the load switching device.

In the case of a single generator system, the **Generator Contactor/Breaker** will be instructed to close. The generator will then supply the requirements of the load.

On a multi-set system, if the common generator bus is live, the 5510 module will first synchronise the generator to the bus before closing the **Generator Contactor/Breaker**.

A 'token' is held by the module that first closed onto the dead bus and as only one token exists for each multi-set system, this prevents other sets in the system from attempting to close their own breakers.

For added security, the modules also monitor the bus. If this is found to be live, then the synchronisation process begins.

Once the load switching device is closed, the 5510 will then ramp to share the load with the other generators in the system.

 **NOTE:-A load transfer will not be initiated until the Oil Pressure has risen. This prevents excessive wear on the engine.**

When the **Remote start** signal is removed, the **Stop** delay timer is initiated. Once this has expired, the module will ramp the load from the generator to remaining set (Multi-set systems only). The Generator Contact/Breaker will open and the **Cooling** timer is then initiated, allowing the engine a cooling down period off load before shutting down. Once the **Cooling** timer expires, the **Fuel Solenoid** is de-energised, bringing the generator to a stop.

For full details of multi-set operation please refer to the manual 'The Guide to sync and load share Pt1'

Should the **Remote Start** signal be re-activated during the cooling down period, the set will return on load.



 **NOTE:- When synchronising is enabled, the bus is checked before closing any load switching device. If the bus is live, synchronising will take place before any closure takes place.**

 **NOTE:- Synchronising can be disabled if the application does not require this function. Contact your genset supplier in the first instance for further details.**

 **NOTE:-** The internal 'Scheduler' can be configured to operate the system in the same manner as described for the Remote start input. Please refer to the 5xxx Configuration Software manuals for full details on the feature.

3.3 MANUAL OPERATION

Manual mode is used to allow the operator to control the operation of the generator, and to provide fault finding and diagnostic testing of the various operations normally performed during Automatic mode operation.

NOTE:- If a digital input configured to panel lock is active, changing module modes will not be possible. Viewing the instruments  and event logs  is NOT affected by panel lock. If panel lock is active the Panel lock indicator (if configured) illuminates.

MANUAL, mode is selected by pressing the  pushbutton. An LED besides the button will illuminate to confirm this operation. When the **START** (I) button is operated, the module will initiate the start sequence.

NOTE: - There is no Start Delay in this mode of operation.

If the **pre-heat** output option has been selected, this timer will be initiated and the auxiliary output selected energised.

After the above delay, the **Fuel Solenoid (or ECU** output if configured) is energised, and then one second later, the **Starter Motor** is engaged.

NOTE:- If the unit has been configured for CAN Bus, compatible ECU's will receive the start command via CAN Bus. Refer to the Manual CAN and DSE Wiring. Part No. 057-004 for more information on utilising DSE modules with electronically controlled engines.

The engine is cranked for a pre-set time. If the engine fails to fire during this cranking attempt then the starter motor is disengaged for the pre-set rest period. Should this sequence continue beyond the set number of attempts, the start sequence will be terminated and **Fail to Start** will be displayed.

Alarm
Shutdown
Fail to start

When the engine fires, the starter motor is disengaged and locked out at a pre-set frequency measured from the Alternator output. Alternatively, a Magnetic Pickup mounted on the flywheel housing can be used for speed detection (This is selected by PC using the 5xx series configuration software). Rising oil pressure can also be used to disconnect the starter motor; however, it cannot be used for underspeed or overspeed detection.

NOTE:- If the unit has been configured for CAN Bus, speed sensing is via CAN Bus.

After the starter motor has disengaged, the **Safety On** timer is activated, allowing Oil Pressure, High Engine Temperature, Under-speed, Charge Fail and any delayed Auxiliary fault inputs to stabilise without triggering the fault.

Once the engine is running, the **Warm Up** timer (if selected) is initiated, allowing the engine to stabilise before it can be loaded. Once the warm up timer has expired the generator is then available to go on load and the **Generator Available LED** will illuminate on the front panel.

If the module has been configured for synchronising and has speed control of the engine governor, during off load running, the engine speed can be changed using the “running editor”. The speed control options are not displayed in the editor unless the engine is running OFF LOAD in MANUAL MODE.

Details of how to access the ‘running editor’ are contained elsewhere in this manual.

The generator will run off load unless:



1. A **Remote Start on load** signal is applied
2. An on-load run is configured in the scheduler.
3. The  **Close Generator** button is pressed.

On a multi-set system, if the common generator bus is live, the 5510 module will first synchronise the generator to the bus before closing the **Generator Contactor/Breaker** to close.

A ‘token’ is held by the module that first closed onto the dead bus and as only one token exists, this prevents other sets in the system from attempting to close their own breakers.

For added security, the modules also monitor the bus. If this is found to be live, then the synchronisation process begins.

During the parallel run the module can be configured to either run at a fixed level output, such as when used in parallel with an infinite bus. Alternatively, it can be configured to load share with other generators on the bus. For full details of these mode please refer to the manual ‘The Guide to sync and load share Pt1’

- If the **Open Generator**  button is pressed while in parallel, the module will ramp the load on the remaining generators and then open the generator contactor/breaker.
- If the **Open Generator**  button is pressed and the generator is connected to the common generator bus then the load is ramped off the generator and the contactor/breaker is opened.

If **Auto** mode is selected and the remote start on load signal not active, and the scheduler is not calling for a run, then the **Return Delay Timer** will start.

Once this has expired then the module will exit **parallel** operation and will ramp the load back to the remaining generators. It will then open the **Generator Contactor/Breaker**. The generator will then run **off** load allowing the engine a **cooling** period.

Selecting **STOP (O)** de-energises the **FUEL SOLENOID**, bringing the generator to a stop.

 **WARNING:** - Operation of the **STOP** button in any mode will stop the generator operation and return the load switching system to a safe state. This operation may lead to loss of supply to the load. It is recommended that the **STOP** button is only operated once the generator is OFF LOAD and the mains supply provides power to the load.

 **NOTE:** - Synchronising can be disabled if the application does not require this function. Contact your genset supplier in the first instance for further details.

 **NOTE:** - When synchronising is enabled, the bus is checked before closing any load switching device. If the bus is live, synchronising will take place before any closure takes place.

 **NOTE:-** Upon closing the load switching device, the module checks that the bus becomes live. If it does not, an alarm is generated to indicate the problem.

4 PROTECTIONS

When an alarm is present the Audible Alarm will sound and the Common alarm LED (if configured) will illuminate.

The audible alarm can be silenced by pressing the **'Mute'** button



The LCD display will jump from the 'Information page' to display the Alarm Page

Alarm	
Warning	← The type of alarm. Shutdown or warning
Low oil pressure	← The nature of alarm, e.g. Low oil pressure.

The LCD will display multiple alarms e.g. "High Engine Temperature shutdown", "Emergency Stop" and "Low Coolant Warning" alarms that may have been triggered. These will automatically scroll round in the order that they occurred.

In the event of a warning alarm the LCD will display the appropriate text. If a shutdown then occurs the module will again display the appropriate text.

Example:-

Alarm
Shutdown High coolant temp

Followed by....

Alarm
Shutdown Emergency stop

Followed by....

Alarm
Warning Low coolant level

The unit will scroll through all active alarms in a continuous loop.

Alarm
Shutdown High coolant temp

Generator available	
L-N 229v	0A
L-L 400 v	50.0Hz
Pf 0.00	0KW

If no alarms are present the LCD will display this default page.

4.1 WARNINGS

Warnings are non-critical alarm conditions and do not affect the operation of the generator system. They draw the operators' attention to an undesirable condition.

In the event of an alarm the LCD will jump to the alarms page and scroll through all active warnings and shutdowns.

BATTERY CHARGE FAILURE, will be displayed if the module does not detect a voltage from the warning light terminal on the auxiliary charge alternator.

Alarm

Warning
Charge alt failure

BATTERY LOW VOLTAGE will be displayed if the module detects that the plant DC supply has fallen below the low volts setting level. The Battery Low Voltage alarm is delayed by the Low DC Volts Delay timer.

Alarm

Warning
Low battery voltage

BATTERY HIGH VOLTAGE will be displayed if the module detects that the plant DC supply has risen above the high volts setting level. The Battery High Voltage alarm is delayed by the High DC Volts Delay timer.

Alarm

Warning
High battery voltage

FAIL TO STOP, will be displayed if the module detects the engine is still running when the 'Fail to stop timer' expires.

Alarm

Fail to stop

 **NOTE:- 'Fail to Stop' could indicate a faulty oil pressure sender - If engine is at rest check oil sender wiring and configuration.**

AUXILIARY INPUTS, auxiliary inputs can be user configured and will display the message as configured in the module.

Example

Alarm
Warning
Bearing temp high

LOW FUEL LEVEL, will be displayed if the fuel level detected by the fuel level sender falls below the low fuel level setting.

Alarm
Warning
Low fuel level

LOW ENGINE TEMPERATURE, if the module detects that the engine coolant temperature has fallen below the low engine temperature pre-alarm setting level, a warning will occur. Alarm Warning Low Coolant Temp will be displayed.

Alarm
Warning
Low Coolant Temp

GENERATOR HIGH CURRENT, if the module detects a generator output current in excess of the pre-set trip a warning is initiated. Alarm Warning High Current will be displayed. If this high current condition continues for an excess period of time, then the alarm is escalated to a shutdown condition. For further details of the high current alarm, please see High Current Shutdown Alarm.

Alarm
Warning
Over current

GENERATOR FAILED TO OPEN, if the module requests the generator contact/breaker to open it will monitor the auxiliary contacts for feedback that this has happened. If the feedback does not confirm the action within the Generator breaker open timer, then the following alarm will occur.

Alarm
Warning
Gen failed to open

MAINTENANCE DUE, The module can be configured to monitor either engine running hours or absolute time, or both. Should either of these values exceed the pre-set service interval the following alarm will occur.

Alarm

Warning
Maintenance Due

The following alarms are only applicable if synchronising is enabled:

FAILED TO SYNCHRONISE, if the module cannot synchronise within the timer allowed by the Synchronising timer a warning is initiated. The LCD will indicate '**FAILED TO SYNC**'.

Alarm

Warning
Failed to synchronise

GENERATOR PHASE SEQUENCE WRONG, if the module detects a phase rotation error, a warning is initiated. The LCD will indicate '**GEN PHASE SEQ WRONG**'.

Alarm

Warning
Gen phase Seq Wrong

BUS PHASE SEQUENCE WRONG, if the module detects a bus phase rotation error a warning is initiated. The LCD will indicate '**BUS PHASE SEQ WRONG**'.

Alarm

Warning
Bus phase Seq Wrong

NEGATIVE PHASE SEQUENCE, if the module detects an imbalance in the load current of each phase above a pre-set level, then the following warning will occur.

Alarm

Warning
Negative phase Sequence

MSC DATA ERROR, if the module detects a problem on the MSC link which prevents the module from communicating correctly with the other modules, then the MSC Data Error alarm will be triggered. Incorrect wiring type or connection may be a possibility.

Alarm

MSC Data Error

MSC TOO FEW SETS, if the module detects fewer modules on the MSC link than the minimum number configured in the unit the MSC Too few sets alarm will be triggered. This may indicate a break in the MSC connection between the sets.

Alarm
MSC Too Few Sets



CAN ECU ERROR, If the module is configured for **CAN Bus instruments** and receives an “error” message from the engine control unit, ‘Can ECU error’ is shown on the module’s display and a warning alarm is generated.

Example

Alarm
Can ECU error
Exhaust high temperature

The display will alternate between the text display and the manufacturers error codes

Alarm
Can ECU error
SPNnnnnnnn
FMInnnnnnn

KW OVERLOAD ALARM

The kW level provided by the set is above the level of the kW Overload pre alarm.

Alarm
kW Overload Alarm

ENGINE INLET TEMPERATURE

The engine inlet temperature (electronic engines only) is above the level of the Engine Inlet Temperature alarm.

Alarm
Engine Inlet Temperature

AVR MAXIMUM TRIM LIMIT

The AVR output is beng controlled to its maximum limit (100%). This can indicate a problem with the setup or control of the AVR.

Alarm
AVR Maximum Trim Limit

4.2 ANALOGUE PRE-ALARMS

The following alarms are termed 'pre-alarms' as they pre warn the operator of a potentially more serious alarm condition. For instance, if the engine temperature rises past the pre alarm level, a warning condition will occur to notify the operator. If the temperature falls below this level, then the alarm ceases and the set will continue to run as normal. However if the temperature continues to rise until the coolant temperature trip point is reached, the warning is escalated and a high coolant temperature shutdown is initiated.

LOW OIL PRESSURE, if the module detects that the engine oil pressure has fallen below the low oil pressure pre-alarm setting level after the **Safety On** timer has expired, a warning will occur. Alarm Warning Low Oil Pressure will be displayed.

Alarm
Warning Low oil pressure

HIGH ENGINE TEMPERATURE, if the module detects that the engine coolant temperature has exceeded the high engine temperature pre-alarm setting level after the **Safety On** timer has expired, a warning will occur. Alarm Warning High Coolant Temperature will be displayed.

Alarm
Warning High coolant temp

OVERSPEED, if the engine speed exceeds the pre-alarm trip a warning is initiated. Alarm Warning Overspeed will be displayed. It is an **immediate warning**.

Alarm
Warning Overspeed

UNDERSPEED, if the engine speed falls below the pre-set pre-alarm after the Safety On timer has expired, a warning is initiated. Alarm Warning Underspeed will be displayed.

Alarm
Warning Underspeed

LOSS OF EXCITATION, the module will monitor the KVAR present on the generator. Should this exceed a pre-set amount of negative Var this indicates a possible loss of excitation on the alternator. The following alarm will then be generated.

Alarm
Warning Loss of Excitation

GENERATOR HIGH FREQUENCY, if the module detects a generator output frequency in excess of the pre-set pre-alarm, a warning is initiated. Alarm Warning High frequency will be displayed, it is an **immediate warning**.

Alarm

Warning
Gen high frequency

GENERATOR LOW FREQUENCY, if the module detects a generator output frequency below the pre-set pre-alarm after the Safety On timer has expired, a warning is initiated. Alarm Warning Low Frequency will be displayed

Alarm

Warning
Gen low frequency

GENERATOR HIGH VOLTAGE, if the module detects a generator output voltage in excess of the pre-set pre-alarm, a warning is initiated. Alarm Warning High voltage will be displayed, it is an **immediate warning**.

Alarm

Warning
Gen high voltage

GENERATOR LOW VOLTAGE, if the module detects a generator output voltage below the pre-set pre-alarm after the Safety On timer has expired, a warning is initiated. Alarm Warning Low Voltage will be displayed.

Alarm

Warning
Gen low voltage

4.3 SHUTDOWNS

Shutdowns are latching and stop the Generator. The alarm must be cleared and the fault removed to reset the module.

NOTE:- The alarm condition must be rectified before a reset will take place. If the alarm condition remains it will not be possible to reset the unit (The exception to this is the Low Oil Pressure alarm and similar 'delayed alarms', as the oil pressure will be low with the engine at rest).

FAIL TO START, if the engine does not fire after the pre-set number of attempts has been made a shutdown will be initiated. Alarm Shutdown Fail To Start will be displayed.

Alarm
Shutdown
Fail to start

EMERGENCY STOP, removal of the **positive DC** Supply from the Emergency Stop input will initiate a shutdown of the Generator and prevent any attempt to restart the Generator until the Emergency Stop push-button has been reset. Additionally it removes the **positive DC** supply from both the Fuel Solenoid and Starter Solenoid.

Alarm Shutdown Emergency Stop will be displayed.

Alarm
Shutdown
Emergency stop

NOTE:- The Emergency Stop positive signal must be present otherwise the unit will shutdown.

LOW OIL PRESSURE, if the module detects that the engine oil pressure has fallen below the low oil pressure trip setting level after the **Safety On** timer has expired, a shutdown will occur. Alarm Shutdown Low Oil Pressure will be displayed.

Alarm
Shutdown
Low oil pressure

HIGH ENGINE TEMPERATURE, if the module detects that the engine coolant temperature has exceeded the high engine temperature trip setting level after the **Safety On** timer has expired, a shutdown will occur. Alarm Shutdown High Engine Temperature will be displayed.

Alarm
Shutdown
High coolant temp

OVERSPEED, if the engine speed exceeds the pre-set trip a shutdown is initiated. Alarm Shutdown Overspeed will be displayed. Overspeed is not delayed, it is an **immediate shutdown**.

Alarm
Shutdown
Overspeed

 **NOTE:-**During the start-up sequence the overspeed trip logic can be configured to allow an extra trip level margin. This is used to prevent nuisance tripping on start-up - Refer to the 55xx series configuration software manual under heading 'Overspeed Overshoot' for details.

UNDERSPEED, if the engine speed falls below the pre-set trip after the Safety On timer has expired, a shutdown is initiated. Alarm Shutdown Underspeed will be displayed.

Alarm
Shutdown
Underspeed

GENERATOR HIGH FREQUENCY, if the module detects a generator output frequency in excess of the pre-set trip a shutdown is initiated. Alarm Shutdown High Frequency will be displayed, it is an **immediate shutdown**.

Alarm
Shutdown
Gen high frequency

GENERATOR LOW FREQUENCY, if the module detects a generator output frequency below the pre-set trip after the Safety On timer has expired, a shutdown is initiated. Alarm Shutdown Low Frequency will be displayed.

Alarm
Shutdown
Gen low frequency

GENERATOR HIGH VOLTAGE, if the module detects a generator output voltage in excess of the pre-set trip a shutdown is initiated. Alarm Shutdown High Volts will be displayed, it is an **immediate shutdown**.

Alarm
Shutdown
Gen high voltage

GENERATOR LOW VOLTAGE, if the module detects a generator output voltage below the pre-set trip after the Safety On timer has expired, a shutdown is initiated. Alarm Shutdown Low Volts will be displayed.

Alarm
Shutdown
Gen low voltage

 **NOTE:-**Generator voltage and frequency alarms can be delayed by the 'Gen Transient ignore' timer. This is to prevent nuisance tripping when applying or removing load on the generator.

OIL PRESSURE SENDER OPEN CIRCUIT, if the module detects a loss of signal from the oil pressure sender (open circuit) a shutdown is initiated. Alarm Shutdown Sender Fault will be displayed. Sender failure is not delayed, it is an **immediate shutdown**.

Alarm
Shutdown
Oil press sender fault

MAGNETIC PICKUP OPEN CIRCUIT, if the module detects a problem with the connection to the magnetic pickup (open circuit) a shutdown is initiated. MPU failure is not delayed, it is an **immediate shutdown**.

Alarm
Shutdown
MPU open circuit

AUXILIARY INPUTS, if an auxiliary input has been configured as a shutdown the appropriate message will be displayed as configured by the user.

Alarm
Shutdown
Bearing temp high

LOSS OF SPEED SIGNAL, if the speed sensing signal is lost during cranking, a shutdown is initiated. Alarm Shutdown Loss of Speed Signal will be displayed.

Alarm
Shutdown
Loss of speed signal

 **NOTE:-** This will only occur if the magnetic pickup speed sensing signal is lost during cranking or during the safety on timer. If the signal is lost during normal operation the Generator will shutdown with an Under-speed alarm.



CAN DATA FAIL, If the module is configured for CANbus operation and does not detect data on the engine CANbus datalink, a shutdown will occur and 'Can data fail' is shown on the module's display.

Alarm
Shutdown
Can data fail



CAN ECU FAIL, If the module is configured for **CANbus** operation and receives a “fail” message from the engine control unit, the engine is shutdown and ‘Can ECU fail’ is shown on the module’s display.

Example

Alarm

**Can ECU fail
Fuel pressure low**

The display will alternate between the text display and the manufacturers error codes

Alarm

**Can ECU fail
SPNnnnnnn
FMInnnnnn**



NOTE: - If the CAN message is a manufacturers specific code, it may not be displayed as text. If this is the case, the display will show the generic manufacturers code only, which must be cross-referenced with the engine manufacturer’s literature. Please contact the engine manufacturer for further assistance.

The above displays show a standard J1939 based system. Other manufacturers systems supported by the module work in a similar way though the exact detail may vary from those illustrated.

Example

Alarm

**Can ECU fail
SPNnnnnn
FMInnnn**

GENERATOR EARTH FAULT, if the module detects a generator earth fault current in excess of the pre-set trip a shutdown is initiated. The LCD will indicate ‘**EARTH FAULT**’. This alarm is configurable between Warning, Shutdown and Electrical Trip. “Shutdown” is the factory default setting.

Alarm

**Shutdown
Earth Fault**

AIR FLAP CLOSED, if the module detects feedback to indicate that the engine air intake flap is closed a shutdown alarm will be initiated.

Alarm

**Shutdown
Air flap closed**

NEGATIVE PHASE SEQUENCE, if the module detects an imbalance in the load current of each phase above a pre-set level, then the following warning will occur.

Alarm

**Shutdown
Negative phase Sequence**

MSC OLD UNITS ON BUS, if the module detects a module on the MSC link which is incompatible with the current module, then the MSC Compatibility alarm will be triggered. Check the configuration (using 5xxx configuration software) to ensure correct MSC mode is selected (Extended functionality / Pre version 6 compatibility) Incompatible modules without configurable MSC mode will need to be replaced with compatible units.

Alarm

MSC old units on bus

MSC ID ERROR, all modules on the MSC link must have an unique ID number. On later modules, ID's are automatically assigned when joining the MSC link. On modules prior to version 5.00, the ID must be set using 5xxx configuration software.

Alarm

MSC ID Error

MSC FAILURE if the module is unable to detect the MSC link then the MSC Failure alarm will be triggered. Incorrect wiring type or connection may be a possibility.

Alarm

MSC Failure

LOSS OF EXCITATION, the module will monitor the KVA_r present on the generator. Should this exceed a pre-set amount of negative VA_r this indicates a possible loss of excitation on the alternator. The following alarm will then be generated.

Alarm

**Warning
Loss of Excitation**

kW OVERLOAD ALARM

The kW level provided by the set is above the level of the kW Overload shutdown alarm.

Alarm

**Shutdown
kW Overload Alarm**

ENGINE INLET TEMPERATURE

The engine inlet temperature (electronic engines only) is above the level of the Engine Inlet Temperature shutdown alarm.

Alarm

**Shutdown
Engine Inlet Temperature**

AVR MAXIMUM TRIM LIMIT

The AVR output is being controlled to its maximum limit (100%). This can indicate a problem with the setup or control of the AVR.

Alarm
Shutdown AVR Maximum Trim Limit

4.4 ELECTRICAL TRIPS

Electrical trips are latching and stop the Generator but in a controlled manner. On initiation of the electrical trip condition the module will de-energise the ‘**Close Generator**’ Output to remove the load from the generator. Once this has occurred the module will start the Cooling timer and allow the engine to cool off-load before shutting down the engine. The alarm must be accepted and cleared and the fault removed to reset the module.

AUXILIARY INPUTS, if an auxiliary input has been configured as an electrical trip the appropriate message will be displayed as configured by the user.

Example

Alarm
Electrical trip Output breaker tripped

The following alarms are configurable between Warning, Shutdown and Electrical Trip. “Electrical Trip” is the factory default setting.

GENERATOR HIGH CURRENT, if the module detects a generator output current in excess of the pre-set trip a warning is initiated. This warning will continue for a period of time depending upon the level of overload that the generator is subjected to and the configuration setting for Generator High Current in the 5xxx series configuration software.

Alarm
Shutdown High current trip

For instance, the factory default settings for Generator High Current allow for a loading of the generator to 110% for one hour. That is to say if the generator load level exceeds the trip point by 10%, a warning alarm will occur while the overload condition exists. If the load level does not drop to normal levels within one hour, the breaker is opened and the set is cooled down and stopped.

 **NOTE:- Higher overload levels will result in a faster acting shutdown condition. For instance with the factory default configuration, an overload level twice that of the trip level (typically 200% of the full load) will result in a Generator High Current shutdown condition after 36 seconds.**
For details of the relationship between the overload and the shutdown time, please see the Appendix section of this manual.

GENERATOR REVERSE POWER, if the module detects a generator reverse power current in excess of the pre-set trip a shutdown is initiated. The LCD will indicate '**GEN REVERSE POWER**'.

Alarm

**Electrical trip
Gen Reverse Power**

GENERATOR SHORT CIRCUIT, if the module detects a generator fault current in excess of the pre-set trip a shutdown is initiated. The LCD will indicate '**GEN SHORT CIRCUIT**'.

Alarm

**Electrical trip
Gen Short Circuit**

LOSS OF EXCITATION, the module will monitor the KVAR present on the generator. Should this exceed a pre-set amount of negative Var this indicates a possible loss of excitation on the alternator. The following alarm will then be generated.

Alarm

**Electrical trip
Loss of Excitation**

NEGATIVE PHASE SEQUENCE, if the module detects an imbalance in the load current of each phase above a pre-set level, then the following warning will occur.

Alarm

**Electrical Trip
Negative phase Sequence**

kW OVERLOAD ALARM

The kW level provided by the set is above the level of the kW Overload Electrical Trip.

Alarm

**Electrical Trip
kW Overload Alarm**

ENGINE INLET TEMPERATURE

The engine inlet temperature (electronic engines only) is above the level of the Engine Inlet Temperature Electrical Trip alarm.

Alarm

**Electrical Trip
Engine Inlet Temperature**

AVR MAXIMUM TRIM LIMIT

The AVR output is being controlled to its maximum limit (100%). This can indicate a problem with the setup or control of the AVR.

Alarm

Electrical Trip



AVR Maximum Trim Limit

4.5 ROCOF / VECTOR SHIFT

When configured to run in parallel with the mains (utility) supply, the module monitors for ROCOF / Vector shift trips according to the module's configuration settings. This is included within the module and will detect failure of the mains supply during parallel operation with the generator.

 **NOTE:- This protection operates only when in parallel with the mains supply and is disabled at all other times.**

Should either of these alarms operate, the module will perform a controlled shutdown (electrical trip) of the generator. This operation must be manually reset :

- 1) Press  button. The engine will stop if it is still running and the alarm is cleared.
- 2) Activate digital input configured to "Clear ROCOF/Vector shift" if this has been provided.
- 3) Press  and  button together and hold for 5 seconds. The ROCOF/Vector shift instrument is displayed and all 'peak hold' values are reset, clearing the ROCOF/Vector shift alarm.

Alarm

Mains ROCOF

Alarm

Mains Vector Shift

Alarm

**Mains Decoupling
Low Frequency**

Alarm

**Mains Decoupling
High Frequency**

Alarm

**Mains Decoupling
Low Voltage**

Alarm

**Mains Decoupling
High Frequency**

For details on activating and configuring the ROCOF/Vector shift protection you are referred to the 5xxx for Windows configuration software manual.

5 DESCRIPTION OF CONTROLS

The following section details the function and meaning of the various controls on the module.

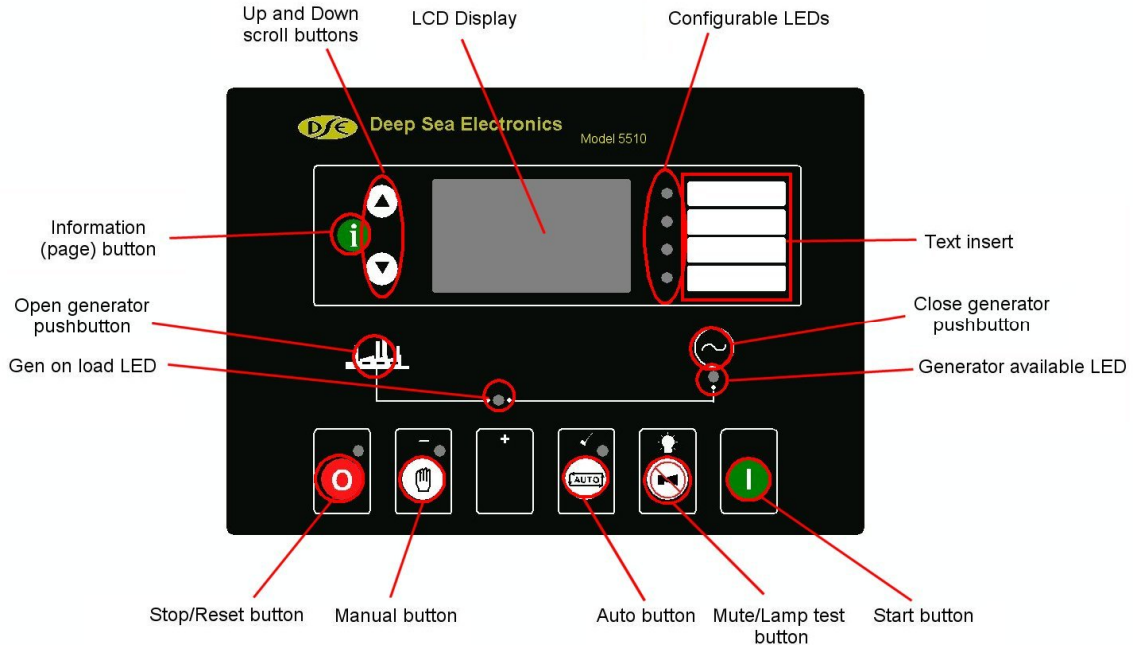

5.1 TYPICAL LCD DISPLAY SCREENS

5.1.1 TYPICAL STATUS DISPLAY

Status	Indicates that the module is in Automatic and that the system is in standby. The unit will respond to an active remote start signal.
Waiting in Auto	

Status	Indicates that the module is in automatic and that a start sequence has been initiated, by remote start input. The module is attempting to crank the generator.
Cranking attempt 2 00.06 Auto mode	

Generator available L-N 229v 0A L-L 400 v 50.0hz Pf 0.00 0KW	If no alarms are present the LCD will display this default page.
--	--

5.1.2 TYPICAL INSTRUMENT DISPLAY

Engine oil pressure	The display of the engine oil pressure
<p style="text-align: center;">6.2 Bar 90 Psi 620 KPa</p>	

Coolant temperature	The display of the engine coolant temperature
<p style="text-align: center;">74 °C 165 °F</p>	

Generator Amps	The display of all three generator line currents.
<p>L1 50A L2 52A L3 50A</p>	

Mains	ROCOF / Vector shift display (For systems configured to parallel with mains supply only) Present values are shown to the left with the 'peak hold' values shown on the right.
<p>ROCOF 0.2Hz 10Hz Vector 1.4° 2°</p>	

5.1.3 TYPICAL ALARM DISPLAY

Alarm	The module is warning that the engine oil pressure has fallen below a pre set level. The generator is not shutdown.
<p>Warning Low oil pressure</p>	

Alarm	The oil pressure has fallen below a second pre set value and has shutdown the generator.
<p>Shutdown Low oil pressure</p>	

Alarm	The module is warning that the battery voltage is below a pre set value.
<p>Warning Low battery Volts</p>	

5.1.4 TYPICAL EVENT DISPLAY



<table border="1"> <tr> <td data-bbox="188 264 564 315"> Event log </td> <td data-bbox="539 264 564 315"> 1 </td> </tr> <tr> <td colspan="2" data-bbox="188 315 564 465"> 17 Jan 2005 16:29:49 Hi Engine temperature </td> </tr> </table>	Event log	1	17 Jan 2005 16:29:49 Hi Engine temperature		<p>On the 17th January 2005 at 16:29 the unit detected a Engine High temperature condition.</p>
Event log	1				
17 Jan 2005 16:29:49 Hi Engine temperature					
<table border="1"> <tr> <td data-bbox="188 506 564 557"> Event log </td> <td data-bbox="539 506 564 557"> 2 </td> </tr> <tr> <td colspan="2" data-bbox="188 557 564 707"> 8 Sep 2004 20:10:05 Emergency stop </td> </tr> </table>	Event log	2	8 Sep 2004 20:10:05 Emergency stop		<p>On the 8th September 2004 at 20:10. The emergency stop button was pressed and the generator was shutdown.</p>
Event log	2				
8 Sep 2004 20:10:05 Emergency stop					
<table border="1"> <tr> <td data-bbox="188 748 564 799"> Event log </td> <td data-bbox="539 748 564 799"> 3 </td> </tr> <tr> <td colspan="2" data-bbox="188 799 564 949"> 7 Sep 2004 08:46:00 Over Volts Shutdown </td> </tr> </table>	Event log	3	7 Sep 2004 08:46:00 Over Volts Shutdown		<p>On the 7th September 2004 at 08:46, the unit detected that the generator output volts exceeded pre-set trip level and has shutdown the generator.</p>
Event log	3				
7 Sep 2004 08:46:00 Over Volts Shutdown					

5.2 VIEWING THE INSTRUMENT AND EVENT LOG PAGES

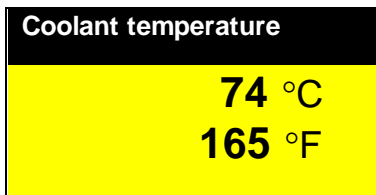
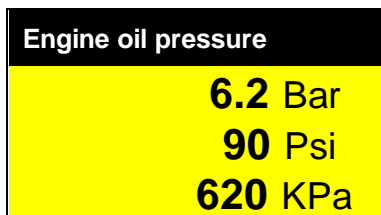
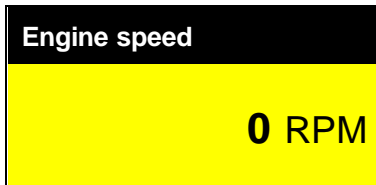
To view a particular instrument, operate the “Page” button  to move to the required page. The LCD will display the page title and then will automatically commence scrolling down the various instruments. On reaching the last instrument, the LCD display will then jump back to the page title and resume scrolling down the page. This sequence will be repeated until either the user moves off the page, the LCD page timer has expired or an alarm condition occurs. In the case of the latter, the module will jump to the alarm page to show the relevant alarm details.



Etc....

It is also possible to scroll to display the different instruments using  and  buttons. Once selected the instrument will remain on the LCD display until the user selects a different instrument or page, or after a period of inactivity, the module will revert to the ‘Status page’.

 **NOTE:-**This description of operation is also true for the other instrument pages and for viewing the records in the event log.

 **NOTE:-** The factory default setting is to show all instruments in a single list. It is possible to change this configuration to a “page” style display using the 5xxx configuration software. When configured to the page style, the instruments are grouped into separate pages – i.e. Engine instruments, Gen instruments, bus instruments.

5.2.1 SYNCHROSCOPE OPERATION

(When enabled)

Display	Detail
	<p>Initial stage of Synchronising display will only show the difference between the Mains Supply and the Generator Output. Here the display is showing a frequency mismatch of +2.9Hz - The genset frequency is too high (indicated by the arrow) and should be reduced. The voltage is +0.2 volts high, but is within the limits set for synchronising.</p>
	<p>Once the difference between the Mains and the Generator frequency has been reduced, the 'Synchroscope' display will become active. The moving bar will roll from one side to the other showing the phase of the two supplies. The area in the centre of the scope indicates the set limits for synchronising to occur.</p>
	<p>Synchronising will only occur when both the Frequency and the voltage differences are within acceptable limits - Indicated by 'Tick' marks on the top of the display. Then the moving bar display will show the phase difference. The engine speed will be automatically adjusted, altering the phase, until the moving bar enters the centre of the scope.</p>
	<p>Once the Mains and generator supplies are synchronised, the module will initiate a breaker close signal to load the generator onto the Mains. Should synchronism be broken the moving bar will pass out of the synchronising window.</p>

▲ Note:-At the start of the synchronising process and if the display is still on the status page, the module will automatically switch to the Synchroscope page. Once the system enters one of the ramping states, the ramp progress will also be displayed on the screen.

▲ NOTE:- If the breaker closing time is too great, then the supplies will drift out of phase before the breaker is closed, an electrical trip alarm will occur and "Out of Sync" will be displayed.

▲ NOTE:- Should the breaker open when on load, and NOT due to an open signal from the 5510, the module will detect "Out of Sync" and generate an electrical trip alarm. For instance, this will occur if the breaker is manually opened, or tripped by a device external to the 5510 controller.

5.3 COMPLETE INSTRUMENTATION LIST

5.3.1 BASIC INSTRUMENTATION

Engine Speed
Engine Oil pressure
Coolant temperature
Fuel level
Battery voltage/Charge alt volts
Engine run time/Number of starts
Next maintenance (if enabled)
Generator volts (L1-N, L2-N, L3-N)
Generator volts (L1-L2, L2-L3, L3-L1)
Generator Hz
Generator Amps (L1, L2, L3)
Generator earth current
Generator kW (L1, L2, L3)
Generator total kW/%
Generator kVA (L1, L2, L3)
Generator total kVA/%
Generator pf (L1, L2, L3)
Generator average pf
Generator kVAh (L1, L2, L3)
Generator total kVAh /%
Generator kWh/Generator kVAh/Generator kVAh
Generator phase sequence
Load Demand priority
Synchroscope (when enabled)
Bus volts (L1-N, L2-N, L3-N)
Bus volts (L1-L2, L2-L3, L3-L1)
Bus Hz
Bus phase sequence

5.3.2 ENHANCED ENGINE INSTRUMENTATION

(When supported by the electronic engine ECU)

Engine oil temperature
Coolant pressure
Inlet manifold temperature
Exhaust temperature
Turbo pressure
Fuel pressure
Fuel consumption
Total fuel used

5.4 ACCESSING THE FRONT PANEL CONFIGURATION EDITOR

This configuration mode allows the operator limited customising of the way the module operates.

Operation	Detail
To enter the 'configuration mode' press both the INFO and STOP buttons together.	

5.4.1 ENTERING THE CONFIGURATION EDITOR PIN NUMBER

The configuration editor contains two sections.

- Main configuration editor (for 'site adjustable' or 'commissioning' parameters)
- Application editor (to allow installation engineers to make application changes).
The 'Application Editor' is designed to allow the module to be configured for different applications without needing to re-configure the module settings. This makes it particularly suitable for applications where the generator would be used in a number of different roles, specifically in Rental or mobile type applications.

If the module PIN number has been set, the PIN number request is then shown. The configuration cannot be viewed or changed until the PIN number is correctly entered.

Enter either the 'main' PIN or the application PIN.

If no PIN has been set, then skip to the next section.

 **NOTE:-** The 'Application Editor' must be enabled first in order to make it accessible from the module's fascia. This is done by setting a PIN (number) for the module's main front panel editor, using the 5xxx for Windows™ PC configuration software.

Enter pin	The first * is flashing. Press + or – buttons to adjust it to the correct value for the first digit of the PIN number. Press ✓ when the first digit is correctly entered.
* * * *	

Enter pin	The second * is now flashing. Press + or – buttons to adjust it to the correct value for the second digit of the PIN number. Press ✓ when the second digit is correctly entered.
1 * * *	



Enter pin	The third * is now flashing. Press + or – buttons to adjust it to the correct value for the third digit of the PIN number. Press ✓ when the third digit is correctly entered.
12 * *	

Enter pin	The fourth * is now flashing. Press + or – buttons to adjust it to the correct value for the fourth digit of the PIN number. Press ✓ when the fourth digit is correctly entered.
123 *	

 **NOTE:-** When ✓ is pressed after editing the final PIN digit, the PIN is checked for validity. If the number is not correct, the editor is automatically exited. To retry you must re-enter the editor as described above.

5.4.2 EDITING VALUES

If the PIN number has not been set, or has been correctly entered :

Operation	Detail
The LCD will then display:	CONFIGURATION
To view the different configuration functions press the + or - buttons.	
The LCD will then display the first item: (example)	CONFIGURATION Oil Pressure Pre-alarm 1.30 Bar 18 PSI 130 kPa
Pressing the ✓ button will enter edit mode :	
The parameter being changed will flash. Pressing + or - buttons will change the parameter to the desired value.	CONFIGURATION Oil Pressure Pre-alarm 1.30 Bar 18 PSI 130 kPa
Press ✓ to save the change. The parameter will stop flashing as the edit mode is exited.	
To view the different configuration functions press the + or - buttons.	
For date and time editing only: press  to select between day, month, year, hours and minutes.	
To exit the ' Operator configuration mode ' save your current value change if you haven't already done so (press ✓ to exit the flashing edit mode), then press Stop/Reset to exit configuration mode.	

The module will then return to the '**Status Page**' display.

5.4.3 LIST OF ADJUSTABLE PARAMETERS IN 'MAIN CONFIGURATION EDITOR'

(Factory default settings are shown in bold italicised text)

Section	Parameter as shown on display	Values	
Input settings	Oil Pressure Pre Alarm	0bar - 4bar (1.17bar)	
	Oil Pressure Shutdown	0bar - 4bar (1.03bar)	
	High Coolant Temp Pre Alarm	80°C - 140°C (115°C)	
	High Coolant Temp Shutdown	80°C - 140°C (120°C)	
Timers	Gen Transient Delay	0 - 10s (0s)	
	Start Delay	0 - 60m (5s)	
	Pre Heat Time	0 - 60m (0s)	
	Crank Time	0 - 60s (10s)	
	Crank Rest Time	0 - 60s (10s)	
	Safety On Delay	0 - 30s (10s)	
	Over speed Overshoot Delay	0 - 10s (0s)	
	Warm Up Time	0 - 60m (0s)	
	Return Delay	0 - 60m (30s)	
	Cooling Run Time	0 - 60m (1m)	
	Fail To Stop Delay	0 - 30s (30s)	
	Low Battery Delay	0 - 10m (1m)	
	High Battery Delay	0 - 10m (1m)	
	Gen Reverse Power Delay	0 - 30s (2s)	
Generator	Generator Under voltage Shutdown	50V-360V ph-N (184V)	
	Generator Under voltage Pre Alarm	50V-360V ph-N (196V)	
	Generator Nominal voltage	52V-330V(230V)	
	Generator Over voltage Pre Alarm	50V-360V ph-N (265V)	
	Generator over voltage Shutdown	50V-360V ph-N (277V)	
	Generator Under Frequency Shutdown	0Hz - 75Hz (40Hz)	
	Generator Under Frequency Pre Alarm	0Hz - 75Hz (42Hz)	
	Generator Nominal Frequency	0Hz - 74Hz (50Hz)	
	Generator Over Frequency Pre Alarm	0Hz - 75Hz (55Hz)	
	Generator Over Frequency Shutdown	0Hz - 75Hz (57Hz)	
	Generator Over Current Trip	100% - 200% full load rating (100%)	
	Generator Short Circuit Trip	50% - 300% full load rating (200%)	
	Generator Reverse Power Trip	0% - 200% full load rating (35kW)	
	Earth Fault Trip	1% - 100% full load rating (10%)	
Engine	Engine Under speed Shutdown	0RPM - 6000RPM (disabled)	
	Engine Under speed Pre Alarm	0RPM - 6000RPM (disabled)	
	Engine Over speed Pre Alarm	0RPM - 6000RPM (disabled)	
	Engine Over speed Shutdown	0RPM - 6000RPM (disabled)	
	Over speed Overshoot	0% - 10% (0%)	
	Plant Battery Under volt Alarm	0V - 40V (10V)	
	Plant Battery Over volt Alarm	0V - 40V (30V)	
	Charge Alternator Failure Alarm	0V - 40V (6V)	
Display	Language	ENGLISH , OTHERS	
AC System	Alternative Frequency	Enable, Disable	
	Alternative Voltage	Enable, Disable	
	AC System	3 Ph 4 wire , 1 Ph 2 wire, 3 ph 3 wire, 2 ph 3 wire L1 & L2 3 ph 4 wire EDISON DELTA 2 ph 3 wire L1 & L3	
	Generator Full Load Current	0A - 8000A (500A)	
	Droop	Enable, Disable	
	Droop %	0% - 5%	Electronic engines only when Droop is enabled
Display	Contrast	<input type="checkbox"/> <input checked="" type="checkbox"/>	
Clock	Date and Time	dd mmm yyyy hh:mm:ss	
Misc.	Run Priority	1-16 (1)	
	Auto Scroll Time	0 - 10s (2.0s)	
CT	Generator CT Primary Rating	0A - 8000A (600A)	Power Cycle After Exit
	Generator CT Secondary Rating	1A, 5A	Power Cycle After Exit
Power	Full kw Rating	0MW-20MW (245kW)	Power Cycle After Exit
	Full kVAR Rating	0MVA-20MVA (258kVA)	Power Cycle After Exit
	Load Ramp Rate	0%-100% (3.0%)	
	Load Level For More Sets	0%-100% (80%)	
	Load Level For Less sets.	0%-100% (70%)	
	Load Parallel Power	0%-100% (172kW)	
	Load Power Factor	0%-100% (1.0pfF OkVAR 0%)	
	Ramp with P123 Present	Enable Disable	
	Reactive Load Ctl Mode	None, VAR Share , VAR Fixed Export	
	Insufficient Capacity Delay	0 - 30m (1s)	
	Insufficient Capacity Action	None , Shutdown, Electrical Trip, Latched Warning, Unlatched Warning	
	AVR Trim limit Delay	Mm:ss (0s)	
	AVR Trim limit action	None /Unlatched warning/Latched warning/Electrical trip/Shutdown	

NOTE:- More comprehensive module configuration is possible using the 5xxx series PC configuration software in conjunction with the P810 PC interface. Please contact us for further details.

NOTE:- Languages are subject to change as the modules are updated. Please contact us for the list of latest supported languages.

5.4.4 LIST OF ADJUSTABLE PARAMETERS IN ‘APPLICATION EDITOR’

(Factory default settings are shown in bold italicised text)

Section	Parameter as shown on display	Values
Application settings	Language	<i>ENGLISH</i> , OTHERS (see note below)
	Alternative Frequency	Enable/ <i>Disable</i>
	Alternative voltage	Enable/ <i>Disable</i>
	AC System	3 phase, 4wire Single phase, 2 wire 3 phase, 3 wire 2 phase, 2wire L1& L2 3 phase, 4 wire ED 2 phase 2 wire L1 & L3
	Generator Full load rating	300-600A (500A)
	Droop	Enable/ <i>Disabled</i>
	Contrast	<input type="checkbox"/> <input checked="" type="checkbox"/>
	Date and Time	dd mmm yyyy hh:mm
	Generator run priority	1-16 (1)
	Auto Scroll Time	0-10s (2.0s)
	Generator CT Primary Rating	5-6000A (600A)
	Generator CT Secondary Rating	1A / 5A
	Mains CT Primary Rating	1A / 5A
	Generator Control Full kw rating	1-5000kW (345kW)
	Generator Control Full kVAr rating	1-5000kVAr (258kW)
	Load ramp rate	0.1-100% (3%)
	Load level for more sets	0-100% (80%)
	Load level for less sets	0-100% (70%)
	Load Parallel Power	0-100% (50% 172Kw)
	Load Power Factor	01-1.00-01 (1.00pf)
	Enable commissioning screens	Yes, No
	Override starting alarms	Yes, No
	Voltage adjust (manual mode only engine running breaker open)	0-100 % (0)
	Frequency adjust (manual mode only engine running breaker open)	0-100 % (0)
	Enable mains decoupling test mode (Off mode only)	Yes-No
	Abandon changes and exit	
Save changes and exit		

 **NOTE:-** More comprehensive module configuration is possible using the 5xxx series PC configuration software in conjunction with the P810 PC interface. Please contact us for further details.







 **NOTE:-** Languages are subject to change as the modules are updated. Please contact us for the list of latest supported languages.













5.4.5 DISPLAY EDITOR

The Display Editor is user to make changes to display language, contrast and run priority mode.

Operation	Detail
To enter the Display Editor press both the UP and DOWN buttons together.	

5.4.6 EDITING 'DISPLAY EDITOR' CONFIGURATION VALUES

Operation	Detail
The LCD will then display: Software version is shown for your convenience. This is the version of firmware within the 5510 controller.	CONFIGURATION Contrast  Software version x.xx
To change the value for the displayed parameter press either the	 buttons to increase or decrease the value.
To view the different configuration functions press the	 button.
The LCD will then display:	CONFIGURATION Language English (United Kingdom) Software version x.xx
To change the value for the displayed parameter press either the	 buttons to increase of decrease the value.
To view the different configuration functions press the	 button.
The LCD will then display: (5510 only when configure for running on load demand)	CONFIGURATION Gen set run priority 1 Software version x.xx
To change the value for the displayed parameter press either the	 buttons to increase of decrease the value.
To view the different configuration functions press the	 button.

<p>The LCD will then display:</p>	<p>CONFIGURATION Enable commissioning Screens? No Software version x.xx</p>
<p>To change the value for the displayed parameter press either the   buttons to increase or decrease the value. For details on the commissioning screens see the commissioning section elsewhere in this manual.</p> <p>To view the different configuration functions press the  button.</p>	
<p>The LCD will then display:</p>	<p>CONFIGURATION Override starting alarms? No Software version x.xx</p>
<p>To change the value for the displayed parameter press either the   buttons to increase or decrease the value.</p> <p>To view the different configuration functions press the  button.</p>	
<p>The LCD will then display:</p>	<p>CONFIGURATION Abandon Changes And exit Software version x.xx</p>
<p>To exit the editor without saving changes press either of the   buttons.</p> <p>To save changes press the  button.</p>	
<p>The LCD will then display:</p>	<p>CONFIGURATION Save Changes And exit Software version x.xx</p>
<p>To exit the editor and save any changes press either of the   buttons.</p> <p>To return to the beginning of the list press the  button.</p>	

The module will then return to the 'Status Page' display.

6 LED INDICATORS AND LOGO INSERT

USER CONFIGURABLE LED's

These LEDs can be configured by the user to indicate any one of **100+ different functions** based around the following:-

- **INDICATIONS** - Monitoring of a digital input and indicating associated functioning user's equipment - *Such as Battery Charger On or Louvre Open, etc.*
- **WARNINGS** and **SHUTDOWNS** - Specific indication of a particular warning or shutdown condition, backed up by LCD indication - *Such as Low Oil Pressure Shutdown, Low Coolant level, etc.*
- **STATUS INDICATIONS** - Indication of specific functions or sequences derived from the modules operating state - *Such as Safety On, Pre-heating, Panel Locked, Generator Available, etc.*

These LEDs are annunciated using a removable insert card. Additionally the module's logo can be changed to suit generator manufacturer's requirements. This can be used for instance to give custom branding to the module, or even include the service telephone number.

DSE have produced the 'insert card creator' software, shipped with the DSE SoftwareCD to ease the production of text and logo insert cards to suit your application.

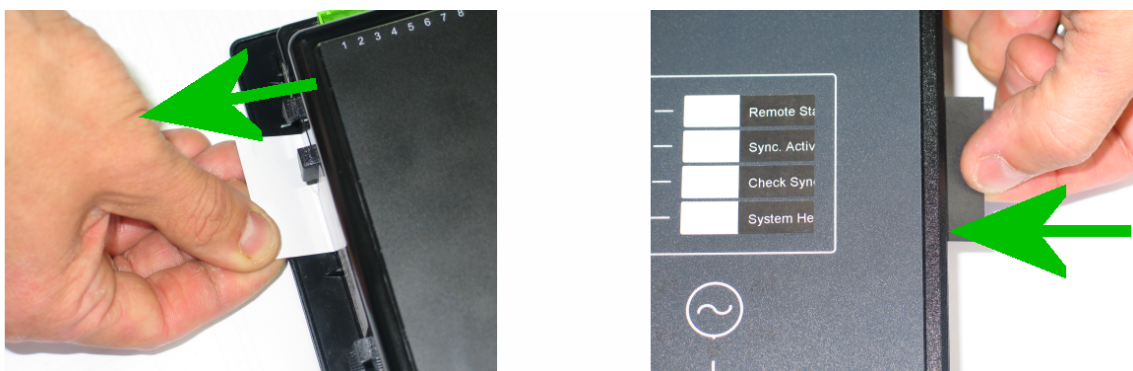

Removal and insertion of the LED text insert card

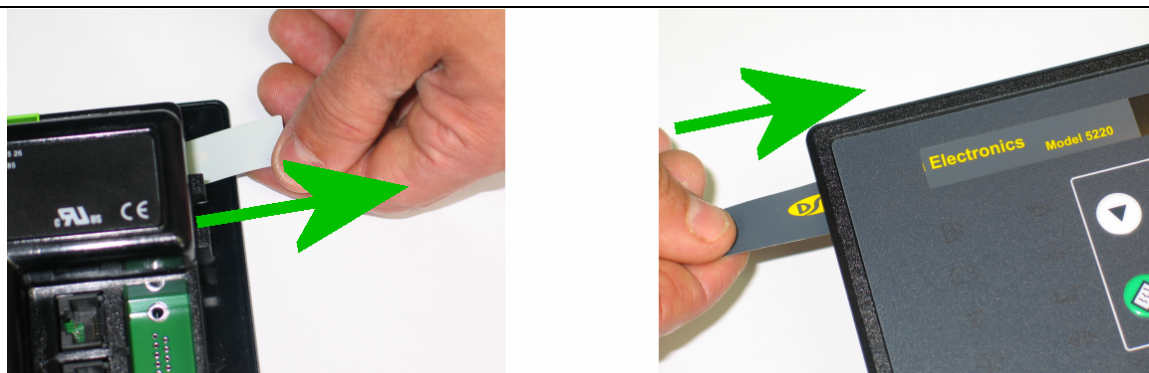





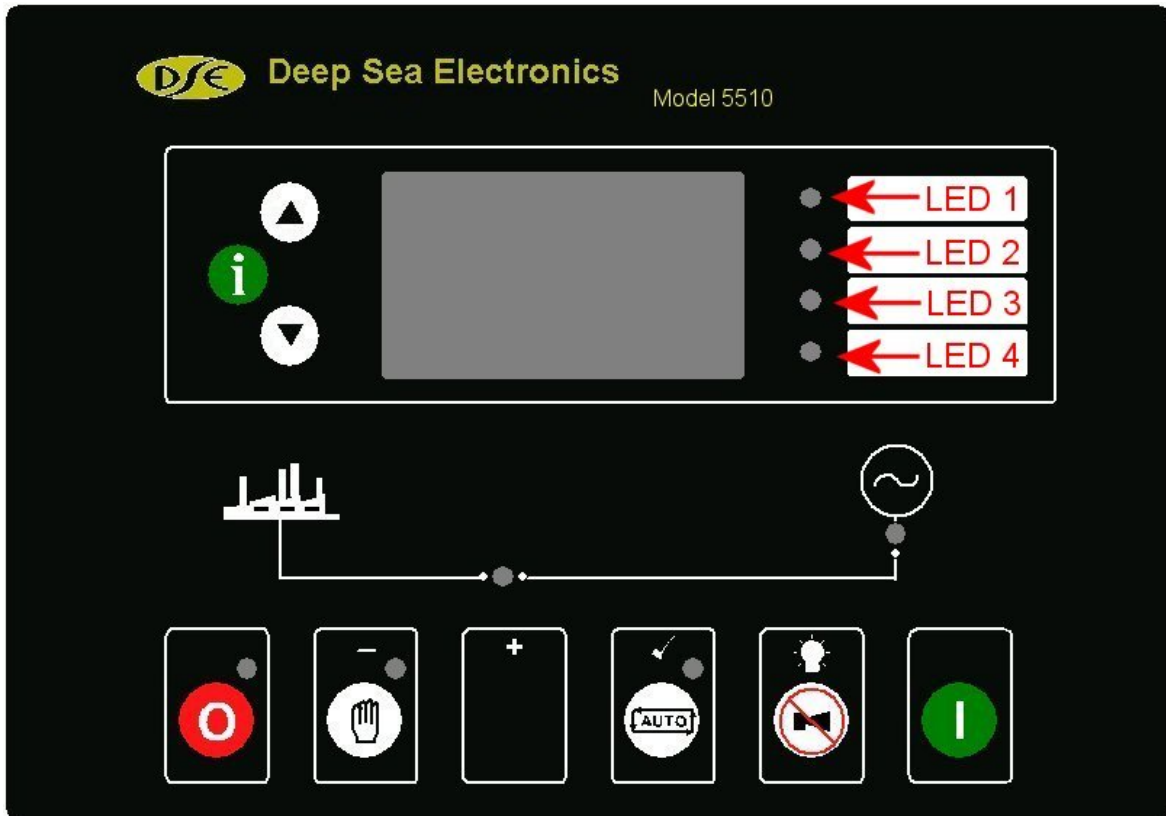

Removal and insertion of the Logo insert card

6.1 LED IDENTIFICATION AND FRONT PANEL LAYOUT



7 CONTROL PUSH-BUTTONS

<p>STOP/RESET</p> <p>This push-button places the module into its Stop/reset mode. This will clear any alarm conditions for which the triggering criteria have been removed. If the engine is running and this push-button is operated, the module will automatically instruct the generator contactor/breaker to unload the generator. The fuel supply will be removed and engine will be brought to a standstill. Should a remote start signal be present while operating in the mode, a remote start will <u>not</u> occur.</p>	
<p>MANUAL</p> <p>This push-button is used to allow manual control of the generator functions. Entering this mode from another mode will initially not cause any change of operating state, but allows further push-buttons to be used to control the generator operation. For example, once in Manual mode it is possible to start the engine by using the 'START' push-button. If the engine is running, off-load in the Manual mode and a remote start signal becomes present, the module will automatically instruct the generator contactor/breaker device to place the generator on load. Should the remote start signal then be removed the generator will remain on load until either the 'STOP/RESET' or 'AUTO' push-buttons are operated.</p>	

<p>START</p> <p>This push-button is used to start the engine. The module must first be placed in the ‘MANUAL’ mode of operation. The ‘START’ button should then be operated. The engine will then automatically attempt to start. Should it fail on the first attempt it will re-try until either the engine fires or the pre-set number of attempts have been made. To stop the engine the ‘STOP/RESET’ button should be operated. It is also possible to configure the module such that the start push-button must be held to maintain engine cranking.</p>	
<p>NOTE:- Different modes of operation are possible - Please refer to your configuration source for details.</p>	
<p>AUTO</p> <p>This push-button places the module into its ‘Automatic’ mode. This mode allows the module to control the function of the generator automatically. The module will monitor the remote start input and once a start condition is signalled the set will be automatically started and placed on load. If the starting signal is removed, the module will automatically transfer the load from the generator and shut the set down observing the stop delay timer and cooling timer as necessary. The module will then await the next start event. <i>For further details, please see the more detailed description of ‘Auto Operation’ earlier in this manual.</i></p>	
<p>ALARM MUTE</p> <p>This push-button is used to silence the internal alarm sounder and also any external sounder devices fed from the audible alarm output. Any further alarm conditions will reactivate the sounder. Once the alarm has been muted and investigated, it may then be cleared.</p> <p><i>Refer to the ‘Protections’ section of this manual for details.</i></p> <p>When the Alarm Mute is operated a Lamp test function will also be implemented and all LED indicators will be illuminated.</p>	
<p>OPEN GENERATOR</p> <p>This push button is used to control the opening of the generator load switching device :</p> <ol style="list-style-type: none"> 1. Pressing this button when the generator is running on load, and in MANUAL mode, the generator load switch is opened. Further presses of this button will have no effect. 	
<p>NOTE:- This button is only active in MANUAL mode.</p>	
<p>CLOSE GENERATOR</p> <p>This push button is used to control the closure of the generator load switching device and has two modes of operation :</p> <ol style="list-style-type: none"> 1. Synchronising is NOT enabled. Pressing this button when the generator is running off load and in MANUAL mode, the generator load switch is closed. Further presses of this button will have no effect. 2. Synchronising is enabled. Pressing this button when the generator is running and in MANUAL mode, the 5510 controller, will volts match and synchronise with the Bus. The generator load switch is then closed in parallel with the Bus. 	
<p>NOTE:- This button is only active in MANUAL mode.</p>	
<p>NOTE:- If the bus is live when the manual button is pressed, synchronising will take place before the load switch is closed.</p>	

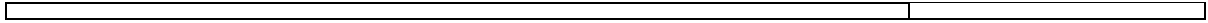

8 INSTALLATION INSTRUCTIONS

The model **DSE 5510** Module has been designed for front panel mounting. Fixing is by 4 clips for easy assembly.

8.1 PANEL CUT-OUT

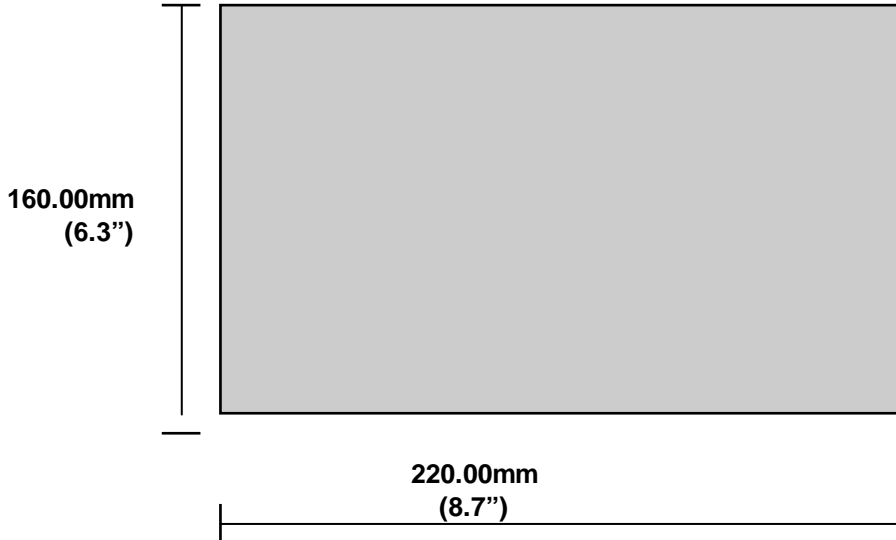

Maximum panel thickness – 8mm (0.3")

In conditions of excessive vibration, the module should be mounted on suitable anti-vibration mountings.

8.2 COOLING

The module has been designed to operate over a wide temperature range **-30°C to +70°C**.

Allowances should be made for the temperature rise within the control panel enclosure. Care should be taken **NOT** to mount possible heat sources near the module unless adequate ventilation is provided. The relative humidity inside the control panel enclosure should not exceed **93%**.

8.3 UNIT DIMENSIONS

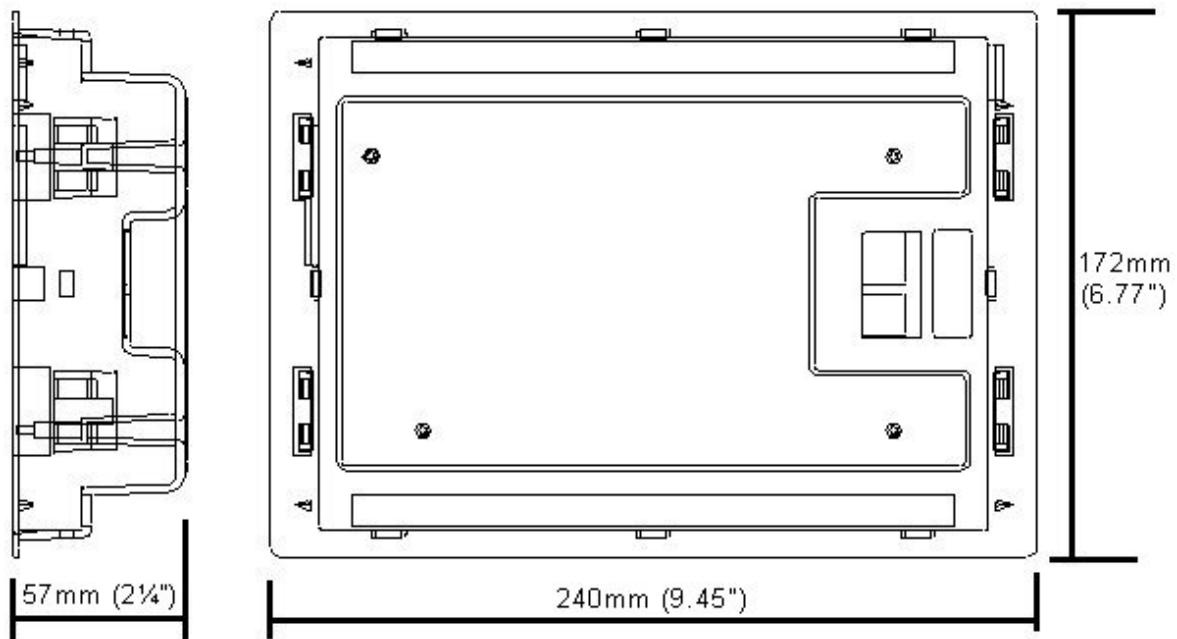

Panel cutout 220mm x 160mm (8.7" x 6.3")

9 ELECTRICAL CONNECTIONS

Connections to the Module are via plug and sockets.

9.1 CONNECTION DETAILS

The following describes the connections and recommended cable sizes to the 8 plugs and sockets on the rear of the Module.

9.1.1 PLUG "A" 8 WAY

PIN No	DESCRIPTION	CABLE SIZE	NOTES
1	DC Plant Supply Input Negative	2.5mm	
2	DC Plant Supply Input Positive	2.5mm	(Recommended Fuse 20A Max.)
3	Emergency Stop Input	2.5mm	Plant Supply positive. Also supplies fuel & start outputs. (Recommended Fuse 32A Max.)
4	Fuel relay Output	2.5mm	Plant Supply positive from pin 3. 16 Amp rated.
5	Start relay Output	2.5mm	Plant Supply positive from pin 3. 16 Amp rated.
6	Auxiliary Output relay 1	1.0mm	Plant Supply positive, 5 Amp rated.
7	Auxiliary Output relay 2	1.0mm	Plant Supply positive, 5 Amp rated.
8	Auxiliary Output relay 3	1.0mm	Plant Supply positive, 5 Amp rated.

9.1.2 PLUG "B" 11 WAY

PIN No	DESCRIPTION	CABLE SIZE	NOTES
9	Charge Fail Input/ Excitation Output	1.0mm	Must NOT be connected to plant supply negative
10	Auxiliary Input 1	0.5mm	Switch to plant supply negative
11	Auxiliary Input 2	0.5mm	Switch to plant supply negative
12	Auxiliary Input 3	0.5mm	Switch to plant supply negative
13	Auxiliary Input 4	0.5mm	Switch to plant supply negative
14	Auxiliary Input 5	0.5mm	Switch to plant supply negative
15	Auxiliary Input 6	0.5mm	Switch to plant supply negative
16	Auxiliary Input 7	0.5mm	Switch to plant supply negative
17	Auxiliary Input 8	0.5mm	Switch to plant supply negative
18	Auxiliary Input 9	0.5mm	Switch to plant supply negative
19	Functional Earth	2.5mm	Connect to system earth

9.1.3 PLUG “C” 9 WAY

PIN No	DESCRIPTION	CABLE SIZE	NOTES
20	Magnetic pickup screen	0.5mm	Connect at module end only!
21	Magnetic pickup	0.5mm	Connect to magnetic pickup device
22	Magnetic pickup	0.5mm	Connect to magnetic pickup device
23	Electronic Engine ECU Screen	0.5mm	Connect screen at one end only
24	Electronic Engine ECU H	0.5mm	120Ω impedance CAN cable
25	Electronic Engine ECU L	0.5mm	120Ω impedance CAN cable
26	Multiset comms Link SCR	0.5mm	Screen for multiset comms link (MSC)
27	Multiset comms Link H	0.5mm	120Ω impedance CAN cable
28	Multiset comms Link L	0.5mm	120Ω impedance CAN cable

▲ NOTE:- Screened cable must be used for connecting the Magnetic Pickup, ensuring that the screen is earthed at one end ONLY.

▲ NOTE:- Screened 120Ω impedance cable specified for use with CANBUS must be used for both the electronic engine link and the Multiset comms link.
DSE stock and supply Belden cable 9841 which is a high quality 120Ω impedance cable suitable for CANbus use (DSE part number 016-030)

9.1.4 PLUG “D” 3 WAY

PIN No	DESCRIPTION	CABLE SIZE	NOTES
29	RS485 SCREEN	0.5mm	Screen for RS485
30	RS485 B	0.5mm	120Ω impedance RS485 cable
31	RS485 A	0.5mm	120Ω impedance RS485 cable

▲ NOTE:- Screened 120Ω impedance cable specified for use with RS485 must be used. DSE stock and supply Belden cable 9841 which is a high quality 120Ω impedance cable suitable for CANbus use (DSE part number 016-030)

9.1.5 PLUG “E” 5 WAY

PIN No	DESCRIPTION	CABLE SIZE	NOTES
32	Governor output B	0.5mm	Connect to governor for speed/load control
33	Governor output A	0.5mm	Connect to governor for speed/load control
34	Unused		Do not connect
35	AVR output B	0.5mm	Connect to governor for volts/VAr control
36	AVR output A	0.5mm	Connect to governor for volts/VAr control

▲ NOTE:- For details of connections to governors and AVRs, refer to the DSE Guide to Synchronising Part 2.

9.1.6 PLUG “F” 8 WAY

PIN No	DESCRIPTION	CABLE SIZE	NOTES
37	Configurable Relay Normally Closed Contact	2.5mm	Can be used for generator load switch “open” or “shunt trip” functionality if required.
38	Configurable Relay Normally Closed Contact	2.5mm	Can be used for generator load switch “open” or “shunt trip” functionality if required.
39	Generator Loading Relay Normally Open Contact	2.5mm	Connect to generator contactor coil feed supply.
40	Generator Loading Relay Normally Open Contact	2.5mm	Connect to generator contactor coil.
41	Bus volts L1	1.0mm	Connect to Bus L1
42	Bus volts L2	1.0mm	Connect to Bus L2
43	Bus volts L3	1.0mm	Connect to Bus L3
44	Bus volts N	1.0mm	Connect to Mains N

NOTE:- If the 5510 module is not being used for synchronising, terminals 37,38, 41,42,43,44 should be left disconnected.

NOTE:- If the 5510 module is synchronising with a mains supply instead of generator bus, then terminals 41,42,43,44 are used for mains supply monitoring.

CAUTION!:- Refer to Typical wiring Diagram for different wiring topologies.

9.1.7 PLUG “G” 4 WAY

PIN No	DESCRIPTION	CABLE SIZE	NOTES
45	Generator volts L1	1.0mm	Connect to Generator L1
46	Generator volts L2	1.0mm	Connect to Generator L2
47	Generator volts L3	1.0mm	Connect to Generator L3
48	Generator volts N	1.0mm	Connect to Generator N

9.1.8 PLUG “H” 12 WAY

PIN No	DESCRIPTION	CABLE SIZE	NOTES
49	CT Secondary for generator L1	2.5mm	Connect to secondary of generator L1 monitoring CT
50	CT Secondary for generator L2	2.5mm	Connect to secondary of generator L2 monitoring CT
51	CT Secondary for generator L3	2.5mm	Connect to secondary of generator L3 monitoring CT
52	Generator CT secondary common	2.5mm	Connect to secondary of all monitoring CT's
53	CT Secondary for generator N	2.5mm	Connect to secondary of generator E (earth fault) monitoring CT
54	Not used		Do not connect
55	Not used		Do not connect
56	Not used		Do not connect
57	Low oil pressure sender	1.0mm	Connect to low oil pressure sender
58	Coolant temperature sender	1.0mm	Connect to Coolant temperature sender
59	Fuel level sender	1.0mm	Connect to Fuel level sender
60	Sender common	1.0mm	Connect to sender common

NOTE*:- If using single terminal senders refer to the Appendix section entitled “Sender wiring recommendations” elsewhere in this manual.

WARNING!:- Do not disconnect this plug when the gen-set is running. Disconnection will open circuit the secondary of the CT's and dangerous voltages may then develop. Always ensure the gen-set is at rest before making or breaking connections to the module.

9.1.9 PC CONFIGURATION INTERFACE CONNECTOR

 810 ✓	8-way connector allows connection to PC via 810 configuration interface. Module can then be re-configured utilising the 5xxx for Windows™ software.
---	---

9.1.10 EXPANSION INTERFACE CONNECTOR

130 / 157 / 545 / 548 ✓ 808 ✗	4-way connector allows connection to the P130 input expansion, P157 relay expansion module or 545/548 LED expansion modules. A maximum of 2 relay or LED expansion modules may be connected in series to this port.
--	--

CAUTION! - Do not connect the 808 configuration interface to this port, as it is not possible to use the 808 software to configure the 5510 module.

9.2 CONNECTOR FUNCTION DETAILS

The following describes the connections and recommended cable sizes to the 8 plugs and sockets on the rear of the Module.

9.2.1 PLUG “A” 8 WAY

PIN No	DESCRIPTION
1	DC Supply Negative. System DC negative input. (Battery Negative).
2	DC Supply Positive. System DC positive input. (Battery Positive).
3	Emergency Stop input. Internally linked to Starter and Fuel outputs. If this input is not connected to positive the module will be locked out and if the engine is running it will shutdown immediately. The Positive Supply also removed from Starter and Fuel therefore only a single pole Emergency Shutdown button is required.
4	Fuel Relay output. Plant Supply Positive from pin 3. Used to control the fuel solenoid or engine fuel control system.
5	Starter Relay output. Plant Supply Positive from pin 3. Used to control the Starter Motor.
6	Auxiliary Relay output 1. Plant Supply Positive Configurable output, see Calibration Manual for options available.
7	Auxiliary Relay output 2. Plant Supply Positive Configurable output, see Calibration Manual for options available.
8	Auxiliary Relay output 3. Plant Supply Positive Configurable output, see Calibration Manual for options available.

9.2.2 PLUG “B” 11 WAY

PIN No	DESCRIPTION
9	Charge Fail input / Excitation output. Supplies excitation to the Plant Battery Charging Alternator, also an input for the Charge Fail detection circuitry.
10	Auxiliary input 1. This is a negative switched configurable input, see Calibration Manual for options available. It is possible to configure the input to be a normally closed signal or a normally open signal.
11	Auxiliary input 2. This is a negative switched configurable input, see Calibration Manual for options available. It is possible to configure the input to be a normally closed signal or a normally open signal.
12	Auxiliary input 3. This is a negative switched configurable input, see Calibration Manual for options available. It is possible to configure the input to be a normally closed signal or a normally open signal.
13	Auxiliary input 4. This is a negative switched configurable input, see Calibration Manual for options available. It is possible to configure the input to be a normally closed signal or a normally open signal.
14	Auxiliary input 5. This is a negative switched configurable input, see Calibration Manual for options available. It is possible to configure the input to be a normally closed signal or a normally open signal.
15	Auxiliary input 6. This is a negative switched configurable input, see Calibration Manual for options available. It is possible to configure the input to be a normally closed signal or a normally open signal.
16	Auxiliary input 7. This is a negative switched configurable input, see Calibration Manual for options available. It is possible to configure the input to be a normally closed signal or a normally open signal.
17	Auxiliary input 8. This is a negative switched configurable input, see Calibration Manual for options available. It is possible to configure the input to be a normally closed signal or a normally open signal.
18	Auxiliary input 9. This is a negative switched configurable input, see Calibration Manual for options available. It is possible to configure the input to be a normally closed signal or a normally open signal.
19	Functional earth

9.2.3 PLUG "C" 9 WAY

PIN No	DESCRIPTION
20	Magnetic pickup screen
21	Magnetic Input positive. An AC signal from the magnetic pickup for speed sensing.
22	Magnetic Input negative. An AC signal from the magnetic pickup for speed sensing.
23	Electronic Engine ECU Screen
24	Electronic Engine ECU H. For connection to the Engine ECU CAN terminal H
25	Electronic Engine ECU L. For connection to the Engine ECU CAN terminal L
26	Multiset comms Link SCR
27	Multiset comms Link H. For connection to other DSE load share modules only.
28	Multiset comms Link L. For connection to other DSE load share modules only.

 **NOTE:-** Screened cable must be used for connecting the Magnetic Pickup, ensuring that the screen is earthed at one end ONLY.

 **NOTE:-** Screened 120Ω impedance cable specified for use with CAN must be used for both the Electronic Engine link and the Multiset comms link.
DSE stock and supply Belden cable 9841 which is a high quality 120Ω impedance cable suitable for CANbus use (DSE part number 016-030)

9.2.4 PLUG "D" 3 WAY

PIN No	DESCRIPTION
29	RS485 SCREEN
30	RS485 B. For connection to other RS485 devices in a multidrop RS485 communications system.
31	RS485 A. For connection to other RS485 devices in a multidrop RS485 communications system.

 **NOTE:-** Screened 120Ω impedance cable specified for use with RS485 must be used.
DSE stock and supply Belden cable 9841 which is a high quality 120Ω impedance cable suitable for CAN use (DSE part number 016-030)

9.2.5 PLUG "E" 5 WAY

PIN No	DESCRIPTION
32	Governor output B. For connection to electronic speed governors for synchronising and load sharing.
33	Governor output A. For connection to electronic speed governors for synchronising and load sharing.
34	Unused
35	AVR output B. For connection to automatic voltage regulators for volts matching and VAR sharing.
36	AVR output A. For connection to automatic voltage regulators for volts matching and VAR sharing.

 **NOTE:-** For details of connections to governors and AVRs, refer to the DSE Guide to Synchronising Part 2.

9.2.6 PLUG “F” 8 WAY

PIN No	DESCRIPTION
37	Configurable Relay, Normally closed. Volts free contacts to 38.
38	Configurable Relay, Normally closed. Volts free contacts to 37.
39	Generator Loading Relay, Normally open. Volts free contacts to 40. Used to connect to generator contactor or circuit breaker.
40	Generator Loading Relay, Normally open. Volts free contacts to 39. Used to connect to generator contactor or circuit breaker.
41	Bus volts L1. Used for sensing the voltage and frequency of Bus L1.
42	Bus volts L2. Used for sensing the voltage and frequency of Bus L2.
43	Bus volts L3. Used for sensing the voltage and frequency of Bus L3.
44	Bus volts N. Used for sensing the Bus voltage and frequency.

⚠ CAUTION!:- Refer to Typical wiring Diagram for different wiring topologies.

9.2.7 PLUG “G” 4 WAY

PIN No	DESCRIPTION
45	Generator volts L1. Used for sensing the voltage and frequency of generator L1.
46	Generator volts L2. Used for sensing the voltage and frequency of generator L2.
47	Generator volts L3. Used for sensing the voltage and frequency of generator L3.
48	Generator volts N. Used for sensing the voltage and frequency of the generator output.

9.2.8 PLUG “H” 12 WAY

PIN No	DESCRIPTION	
49	CT Secondary for generator I1 (s2)	Used for sensing generator output current for metering of Amps, KW, KVA and KVA _r . Provides protection for overcurrent, reverse power, earth fault and also load sharing.
50	CT Secondary for generator I2 (s2)	
51	CT Secondary for generator I3 (s2)	
52	Generator CT secondary common (s1)	
53	CT Secondary for generator IN (s2)	
54	Not used	Not used – do not connect
55	Not used	
56	Not used	
57	Low oil pressure sender	If using single terminal senders refer to the appendix section entitled ‘Sensor Wiring recommendations’ elsewhere in this manual.
58	Coolant temperature sender	
59	Fuel level sender	
60	Sender common	

⚠ WARNING! - Do not disconnect this plug when the generator set is running. Disconnection will open circuit the secondary of the CT’s and dangerous voltages may then develop. Always ensure the generating set is at rest before making or breaking connections to the module.

9.3 ENGINE CONTROL UNIT INTERFACE

The module is capable of interfacing with the ECU fitted to electronically controlled engines. Different manufacturers of engines utilise various different interfaces and protocols. As this is a rapidly developing area, we recommend checking with DSE Support as to which engines are currently supported.







The module will monitor the engines operating parameters such as engine speed, oil pressure, engine temperature (among others) in order to closely monitor and control the engine. The data gathered by the engine controller is transmitted via an industry standard communications interface. This allows generator controllers such as the DSE 55xx range to access these engine parameters with no physical connection to the sensor device.

Utilising the technology present on the engine in this way gives fewer connections to the engine, higher reliability and better diagnosis of engine related problems.

 **NOTE:- For further details for connections to electronic engines refer to the manual CAN and DSE Wiring. Part No. 057-004**

10 SPECIFICATION

DC Supply	Continuous voltage rating : 8V to 35V
	Cranking dip protection : Able to survive 0V for 50mS, providing supply was at least 10V before dropout and supply recovers to 5V. This is achieved without the need for internal batteries
	Charge Fail/ Excitation: 0V to 35V fixed power source 25W
	Max. Standby Current: 375mA at 12V. 200mA at 24V.
	Max. Operating Current: 460mA at 12V. 245mA at 24V
Alternator Input	Range: 5V - 277(ph-N) (+20%) 50Hz - 60Hz (Minimum 15V AC Ph-N)
	Accuracy: 1% of full scale True RMS sensing
	Supported topologies: 3 Phase 4wire Wye 3 phase 3 wire Delta 3 phase 3 wire Edison Delta Single phase 2 wire 2 Phase 3wire L1 & L2 2 Phase 3 wire L1 & L3
Bus Input	Range: 15V - 277(ph-N) (+20%) 50Hz - 60 Hz
	Accuracy: 1% of full scale True RMS sensing
	Supported topologies: 3 Phase 4wire Wye 3 phase 3 wire Delta 3 phase 3 wire Edison Delta Single phase 2 wire 2 Phase 3wire L1 & L2 2 Phase 3 wire L1 & L3
CT's	Burden: 0.5VA
	Primary rating: 1A - 6000A (user selectable)
	Secondary rating: 1A or 5A secondary (user selectable)
	Accuracy of measurement: 1% of full load rating (when using 0.5% or better CTs with 5A secondary winding) Lower class CTs will reduce the overall accuracy of the reading.
	Recommendations: Class 1 required for instrumentation Protection class required if using for protection.
Magnetic Pickup	Voltage range : +/- 0.5V minimum (during cranking) to 70V Peak
	Frequency range: 10,000 Hz (max)
Relay outputs	Fuel: 16 Amp DC at supply voltage
	Start: 16 Amp DC at supply voltage
	Auxiliary outputs 1,2,3: 5 Amp DC at supply voltage
	Output 4 (Generator loading relay) Voltage free, normally open, 8 Amp 250V AC RMS rated
	Output 5 (spare) Voltage free, normally closed, 8 Amp 250V AC RMS rated

Dimensions	Overall: 240mm x 172 mm x 57mm (9 ½" x 6 ¾" x 2 ¼")		
	Panel cut-out: 220mm x 160mm (8.7" x 6.3") Max panel thickness 8mm (0.3")		
Electrical Safety /Electromagnetic Compatibility	BS EN 60950 Safety of information technology equipment, including electrical business equipment		
	BS EN 61000-6-2 EMC Generic Emission Standard (Industrial)		
	BS EN 61000-6-4 EMC Generic Emission Standard (Industrial)		
Environmental	BS EN 60068-2-1 Cold Temperature -30°C		
	BS EN 60068-2-2 Hot Temperature +70°C		
	BS2011-2-1 Humidity 93% RH@40°C for 48 Hours		
	BS EN 60068-2-6 Vibration 10 sweeps at 1 octave/minute in each of 3 major axes 5Hz to 8Hz @ +/-7.5mm constant displacement 8Hz to 500Hz @ 2gn constant acceleration		
	BS EN 60068-2-27 Shock 3 Half sine shocks in each of 3 major axes 15gn amplitude, 11mS duration		
	BS EN 60529 Degrees of protection provided by enclosures: IP55 (Front of module when module is installed into the control panel with the optional sealing gasket). IP42 (front of module when module is installed into the control panel WITHOUT being sealed to the panel)		
	NEMA Rating (Approximate) 12 (Front of module when module is installed into the control panel with the optional sealing gasket). 2 (front of module when module is installed into the control panel WITHOUT being sealed to the panel)		
Product Certification	 European CE approved.	 UL approved C-UL / CSA approved.	 Russia and other CIS countries approved
	 BS EN 2002/95/EC Restriction of Hazardous Substances (RoHS)	 BS EN 2002/96/EC Waste Electrical and Electronic Equipment (WEEE)	 CAN interface certified by MTU for use with MDEC engines
Relevant Company Certification	 BS EN ISO 9001:2000 Applicable to Design, marketing, assembly, service and repair of electronic control modules		

In line with our policy of continual development, Deep Sea Electronics, reserve the right to change specification without notice.

11 COMMISSIONING

Before the system is started, it is recommended that the following checks are made:-

- 6.1. The unit has adequate cooling and all the wiring to the module is of a standard and rating compatible with the system.
- 6.2. The unit **DC** supply is fused and connected to the battery and that it is of the correct polarity.
- 6.3. The Emergency Stop input is wired to an external normally closed switch connected to **DC** positive.

 **NOTE:- If Emergency Stop feature is not required link this input to the DC Positive. The module will not operate unless either the Emergency Stop is fitted correctly OR Pin 3 is connected to DC positive.**

- 6.1. To check the start cycle operation take appropriate measures to prevent the engine from starting (disable the operation of the fuel solenoid). After a visual inspection to ensure it is safe to proceed, connect the battery supply. Press the **"MANUAL"** pushbutton, then press the **'START'** pushbutton for a short time. The unit start sequence will commence.
- 6.2. The starter will engage and operate for the pre-set crank period. After the starter motor has attempted to start the engine for the pre-set number of attempts the LCD will display *'Shutdown Failed to start'*. Press the **STOP/RESET** pushbutton to reset the unit.
- 6.3. Restore the engine to operational status (reconnect the fuel solenoid), again select **"MANUAL"** and operate the **'START'** pushbutton, this time the engine should start and the starter motor should disengage automatically. If not then check that the engine is fully operational (fuel available, etc.) and that the fuel solenoid is operating. The engine should now run up to operating speed. If not and an alarm is present, check the alarm condition for validity, then check input wiring. The engine should continue to run for an indefinite period. It will be possible at this time to view the engine and alternator parameters - refer to the 'Description of Controls' section of this manual.
- 6.4. Select **"AUTO"** on the front panel, the engine will run for the pre-set cooling down period, then stop. The generator should stay in the standby mode. If not check that there is not a signal present on the **Remote Start** input.
- 6.5. Initiate an automatic start by supplying the remote start signal. The start sequence will commence and the engine will run up to operational speed. Once the generator is available a load transfer will take place, the Generator will accept the load. If not, check the wiring to the Generator Contactor Coil (*if used*). Check the Warming timer has timed out.
- 6.6. Remove the remote start signal, the return sequence will start. After the pre-set time period, the load will be removed from the generator. The generator will then run for the pre-set cooling down period, then shutdown into its standby mode.
- 6.7. Further details on synchronising and load sharing can be found in the DSE Guide to Load Share system Design and Commissioning and the DSE Guide to Synchronising and load sharing Part1 and Part2.
- 6.8. If despite repeated checking of the connections between the **5510** and the customer's system, satisfactory operation cannot be achieved, then the customer is requested to contact the factory for further advice on:-

Should you have any queries arising from this manual please contact our Technical Department:

INTERNATIONAL TEL: +44 (0) 1723 890099

INTERNATIONAL FAX: +44 (0) 1723 893303

E-mail: support@deepseapl.com

Web: <http://www.deepseapl.com>

11.1 BYPASSING ALARMS AT STARTUP

When “override starting alarms” is enabled using the Display Editor, it allows alarms to be overridden during the start process by holding the start **I** button. This allows (for instance) the AVR / Governor to be setup without the engine being shutdown on under volts or underfrequency etc. This operation is a ‘one off’ operation, the function is automatically changed back to “No” and must be manually enabled if it is required once more.

The alarms that are overridden during this time are : Undervolts shutdown, Overvolts shutdown, underfrequency shutdown, underspeed shutdown.

The ‘pre-alarms’ remain active to give attention to the operator that an alarm is active, the set will continue to run to allow the operator to adjust the set to nominal speed / voltage.

 **NOTE:- Overfrequency and Overspeed are NOT disabled when this function is activated.**

11.2 COMMISSIONING SCREENS

Commissioning screens are available to both aid the commissioning process and also to give additional information about the synchronising and load sharing process.

These screens can be enabled and disabled in the module’s display editor.

11.2.1 SCREEN 1

L-N	0V	kW	0	Average L-N Voltage and total kW
Amps	0A	KVAr	0	Maximum Amps and total kVAr
Pf	0.00	kW	0.0%	Average power factor and % of full load kW
Gov	0.0%	Avr	0.0%	Levels of analogue governor / AVR outputs.

11.2.2 SCREEN 2

Tgt	0.0%	kW	0.0%	Target and actual % of full load kW
Tgt	0.0%	KVAr	0.0%	Target and actual % of full load kVAr
pf	0.0	Ramp	5.0%	Average power factor and ramp position.
Gov	0.0%	Avr	0.0%	Levels of analogue governor / AVR outputs.

12 FAULT FINDING

SYMPTOM	POSSIBLE REMEDY
Unit is inoperative	Check the battery and wiring to the unit. Check the DC supply. Check the DC fuse.
Unit shuts down	Check DC supply voltage is not above 35 Volts or below 9 Volts Check the operating temperature is not above 55 °C. Check the DC fuse.
Unit locks out on Emergency Stop	If an Emergency Stop Switch is not fitted, ensure that a positive is connected to the Emergency Stop input. Check emergency stop switch is functioning correctly. Check Wiring is not open circuit.
Intermittent Magnetic Pick-up sensor fault	Ensure that Magnetic pick-up screen is only connected at one end, if connected at both ends this enables the screen to act as an aerial and will pick up random voltages.
Low oil Pressure fault operates after engine has fired	Check engine oil pressure. Check oil pressure switch/sender and wiring. Check configured polarity (if applicable) is correct (i.e. Normally Open or Normally Closed) or that sender is compatible with the 5510 Module.
High engine temperature fault operates after engine has fired.	Check engine temperature. Check switch/sender and wiring. Check configured polarity (if applicable) is correct (i.e. Normally Open or Normally Closed) or that sender is compatible with the 5520 Module.
Shutdown fault operates	Check relevant switch and wiring of fault indicated on LCD display. Check configuration of input.
Warning fault operates	Check relevant switch and wiring of fault indicated on LCD display. Check configuration of input.
Fail to Start is activated after pre-set number of attempts to start	Check wiring of fuel solenoid. Check fuel. Check battery supply. Check battery supply is present on the Fuel output of the module. Check the speed sensing signal is present on the 5520 inputs. Refer to engine manual.
Continuous starting of generator when in AUTO	Check that there is no signal present on the "Remote Start" input. Check configured polarity is correct.
Generator fails to start on receipt of Remote Start signal or under mains failure conditions.	Check Start Delay timer has timed out. If remote start fault, check signal is on "Remote Start" input. Confirm input is configured to be used as "Remote Start".
Pre-heat inoperative	Check wiring to engine heater plugs. Check battery supply. Check battery supply is present on the Pre-heat output of module. Check pre-heat has been selected in your configuration.
Starter motor inoperative	Check wiring to starter solenoid. Check battery supply. Check battery supply is present on the Starter output of module. Ensure that the Emergency Stop input is at battery positive.
Engine runs but generator will not take load	Check Warm up timer has timed out. Ensure generator load inhibit signal is not present on the module inputs.

 **NOTE:-** The above fault finding is provided as a guide check-list only. As it is possible for the module to be configured to provide a wide range of different features always refer to the source of your module configuration if in doubt.

13 TYPICAL WIRING DIAGRAM

13.1 CONNECTIONS FOR 3 CT SYSTEM

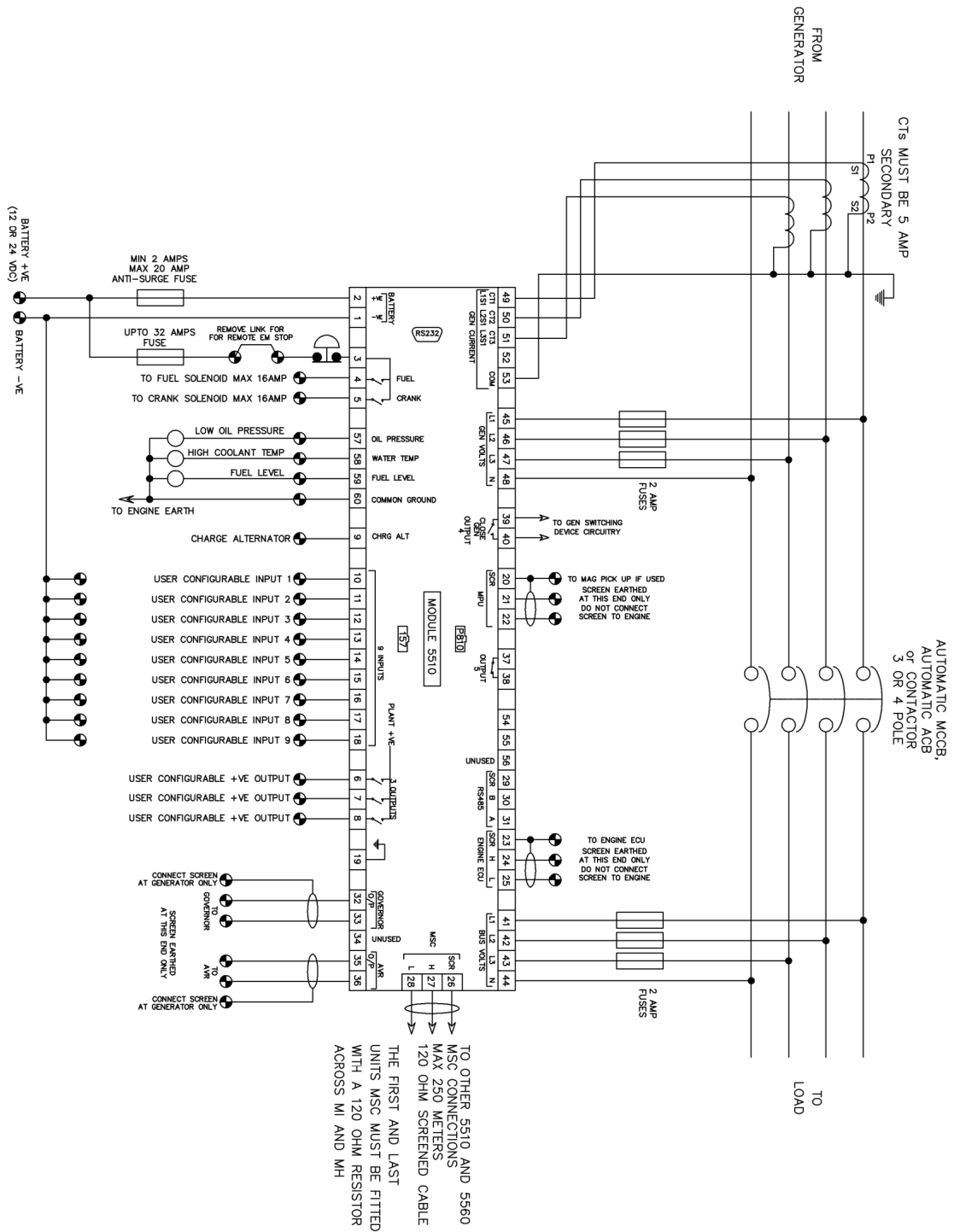

13.2 CONNECTIONS FOR 4 CT SYSTEM

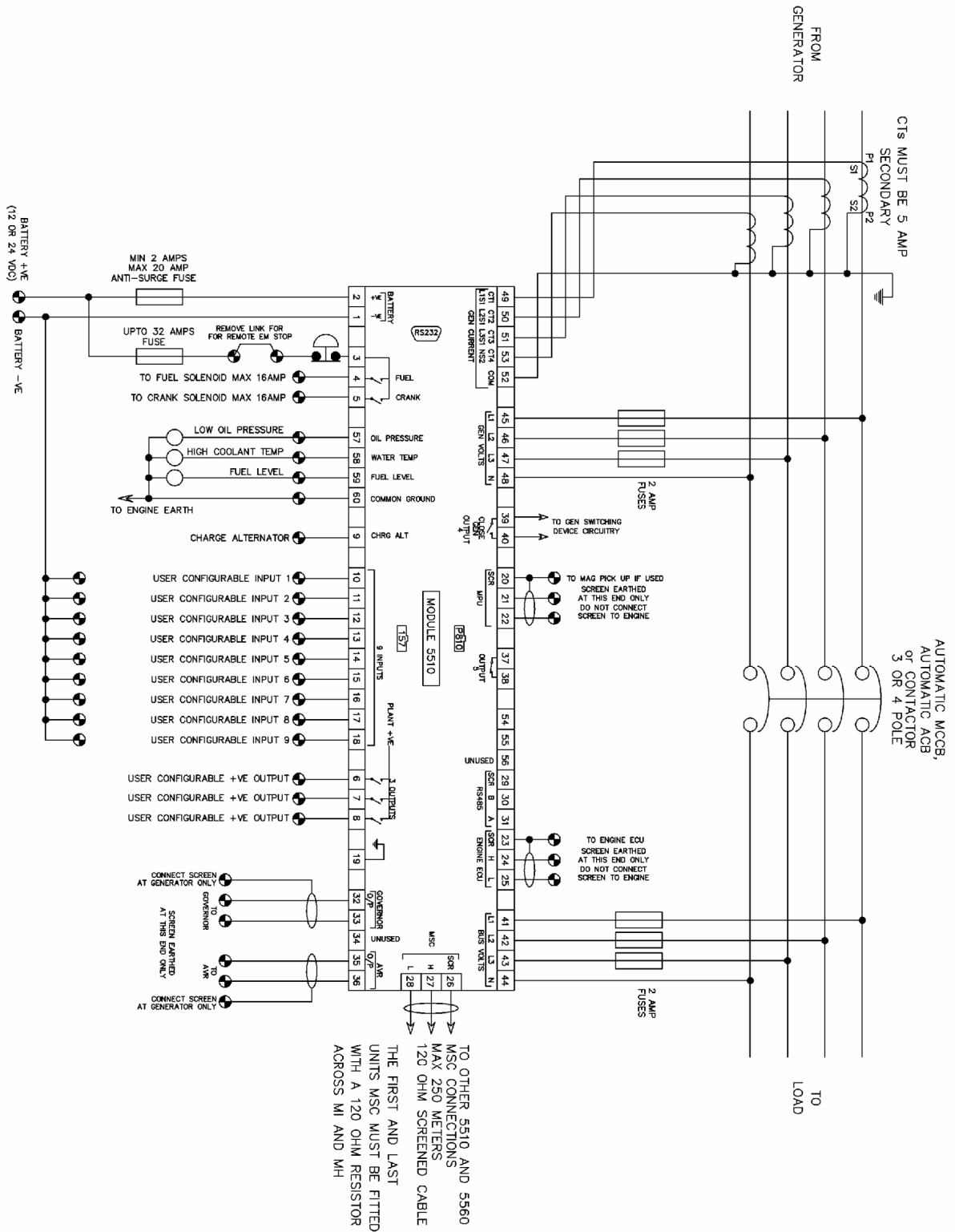

14 FACTORY DEFAULT CONFIGURATION

55xx for Windows. Configuration for 5510 module. Page 1 of 4

Configuration description

1
2
3
4

Filename - 5510a.ycf

Printed on 24/10/2006 11:37:20

Module settings

Base module	5510 remote start module
Module version	8.00
Load control option fitted	Yes
Multiset Communications (MSC) Link	Extended functionality

Application settings

CANbus Enabled	No
Gas engine enabled	No
AC System	3 phase, 4 wire
Enable generator sequence alarm	Yes
Phase sequence	L1 L2 L3
Generator fitted	Yes
Magnetic pickup fitted	No
	Alternator poles 4

Miscellaneous settings

Start button must be held down to crank	No
Audible alarm prior to starting	No
Number of start attempts	3
Enable fast loading feature	No
All warnings are latched	No
Single list instrument display	Yes

Input settings

Low oil pressure input type	VDO 10 bar			
High coolant temp input type	VDO 120 degrees C			
Fuel level input type	Not used			
	Trip	Return		
Low oil pressure pre-alarm	1.17 / 17.0 / 117	1.24 / 18.0 / 124	Bar / PSI / Kpa	
Low oil pressure shutdown	1.03 / 14.9 / 103		Bar / PSI / Kpa	
High coolant temp pre-alarm	115°C	110°C		239°F
High coolant temp shutdown	120°C			248°F
Low coolant temperature	<Disabled>			

Digital Inputs

1 Remote start on load	Close to activate			
2 Remote start on load demand	Close to activate			
3 User configured	Close to activate	Indication		Never active
Activation delay	0.0s	Active text :	Digital input 3	
4 Generator closed auxiliary	Close to activate			
5 User configured	Close to activate	Shutdown		Always active
Activation delay	0.0s	Active text :	Digital input 5	
6 User configured	Close to activate	Shutdown		Active from safety on
Activation delay	0.0s	Active text :	Digital input 6	
7 User configured	Close to activate	Electrical trip		Active from safety on
Activation delay	0.0s	Active text :	Digital input 7	
8 User configured	Close to activate	Indication		Always active
Activation delay	0.0s	Active text :	Digital input 8	
9 Panel lock	Close to activate			

Expansion input settings

P130 expansion enabled	No
------------------------	----

55xx for Windows. Configuration for 5510 module. Page 2 of 4

Configuration description

1
2
3
4

Filename - 5510a.ycf

Printed on 24/10/2006 11:37:20

Output settings

Module relays

1 Energise	Preheat (during pre-heat timer)
2 Energise	Common alarm
3 Energise	System in auto mode
4 Energise	Close generator
5 Energise	Output not used

Expansion Outputs A

1 Energise	Output not used
2 Energise	Output not used
3 Energise	Output not used
4 Energise	Output not used
5 Energise	Output not used
6 Energise	Output not used
7 Energise	Output not used
8 Energise	Output not used

Expansion Outputs B

1 Energise	Output not used
2 Energise	Output not used
3 Energise	Output not used
4 Energise	Output not used
5 Energise	Output not used
6 Energise	Output not used
7 Energise	Output not used
8 Energise	Output not used

LED settings

1 Lit	Remote start on load
2 Lit	Panel locked by digital input
3 Lit	Delayed alarms armed
4 Lit	Digital input 8 active

Timer settings

Starting timers

Start delay	5s
Pre-heat	0s
Pre-heat bypass	0m
Sensor fail delay	2.0s
Cranking time	10s
Crank rest time	10s
Smoke limit	0s
Smoke limit off	0s
Safety on delay	10s
Overspeed overshoot	0s

Load timers

Warming up time	0s
Breaker close pulse	0.5s
Breaker trip pulse	0.5s

Digital input 4 is assigned to generator auxiliary contact

Gen fail to close	1.0s
Gen fail to open	1.0s

No digital input is assigned to mains auxiliary contact

Return delay	30s
Cooling time	1m
ETS solenoid hold	0s
Fail to stop delay	30s

Other timers

Batt low volts delay	1m
Batt high volts delay	1m
LCD auto scroll timer	2s
LCD page timer	5m
Reverse power alarm	2.0s
Generator transient delay	0.0s
Out of sync delay	0.2s

55xx for Windows. Configuration for 5510 module. Page 3 of 4

Configuration description

1
2
3
4

Filename - 5510a.ycf

Printed on 24/10/2006 11:37:20

Mains decoupling

Generator settings

Voltage and frequency settings

	Trip	Return
Under volts trip	184V Ph-N	
Under volts pre-alarm	196V Ph-N	207V Ph-N
Nominal generator voltage	230V Ph-N	
Over volts pre-alarm	265V Ph-N	254V Ph-N
Over volts trip	277V Ph-N	
Under frequency trip	40.0 Hz	
Under frequency pre-alarm	42.0 Hz	45.0 Hz
Nominal generator frequency	50.0 Hz	
Over frequency pre-alarm	55.0 Hz	52.0 Hz
Over frequency trip	57.0 Hz	
Alternative voltage select	No	230v norm / 115v alt
Alternative frequency select	No	50Hz norm / 60Hz alt
Loading voltage	207V Ph-N	
Loading frequency	45.0 Hz	

Current settings

CT primary	600 A
CT secondary	5 A
Generator full load rating	500 A
Earth fault CT primary rating	600 A

	Trip	Curve/Multiplier	Action
Delayed overcurrent	100% (500 A)	36	Electrical trip
Short circuit	200% (1000 A)	33	Electrical trip
Earth fault	10% (50.0 A)	1000	Shutdown
Negative phase sequence			<Disabled>

Power settings

	Trip	Action
Reverse power	35.0 kW	Electrical trip

Synchronising (auto sync) settings

Governor interface	Internal analogue
Governor output reversed	No
Action when on load	Adjust to nominal frequency
AVR interface	Internal analogue
AVR output reversed	No
Action when on load	Adjust to nominal voltage
Enable ramping with PI23 interface	No

Synchronising (check sync) settings

Enable synchronising	Yes	
Dead bus relay	20V Ph-N	
Check sync lower frequency	-0.1 Hz	
Check sync upper frequency	0.2 Hz	
Check sync RMS voltage	2.0V Ph-N	
Check sync phase angle	5°	
Fail to sync time	1m	Warning

Multi-set system settings

MultiSet comms failure action	Warning
Too few modules action	<Disabled>
Minimum modules on MultiSet comms link	1
MultiSet comms alarms disabled action	<Disabled>
Starting options	Start all sets initially
Balance engine hours	<Disabled>
Load level for less sets to run	70%
Load level for more sets to run	80%

Load control

kW Load control mode	kW share
Generator full load rating	345 kW (431 KVA)
Reactive load control mode	VAr share
Generator full VAr rating	258 kVAr (0.80 pf)
Load ramp rate	3.0 percent per second
Loss of excitation warning	<Disabled>
Loss of excitation trip	<Disabled>

55xx for Windows. Configuration for 5510 module. Page 4 of 4

Configuration description

1
2
3
4

Filename - 5510a.ycf

Printed on 24/10/2006 11:37:20

Engine settings

Crank disconnect	Trip	
Crank disconnect on generator frequency	21.0 Hz	
Crank disconnect on generator voltage	<Disabled>	
Crank disconnect on charge alternator	<Disabled>	
Crank disconnect on oil pressure	<Disabled>	Bar / PSI / Kpa
Check oil pressure prior to starting	Yes	

Speed settings	
Overspeed overshoot	0%

Plant battery settings	Trip	Return
Under volts warning	10.0V DC	10.5V DC
Over volts warning	30.0V DC	29.5V DC
Charge alternator warning	6.0V DC	

Maintenance alarm settings	
Enable maintenance alarm	No

Exercise scheduler settings

Enable exercise scheduler	No
---------------------------	----

Language settings

Default language	English (UK)
User defined language 1	Chinese (Simplified)
User defined language 2	French (France)
User defined language 3	Spanish (International)
User defined language 4	Not used

15 SENDER WIRING RECOMMENDATIONS

15.1 USING EARTH RETURN (SINGLE WIRE) SENDERS.

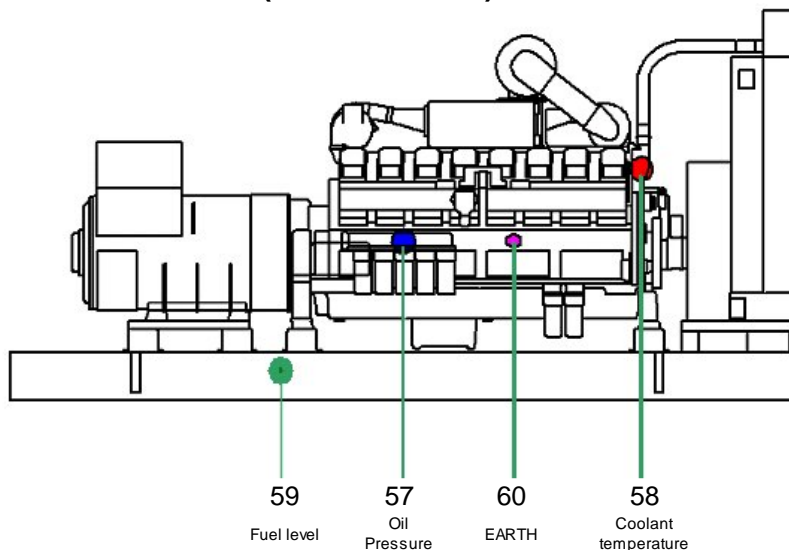

NOTE:- . It is important that terminal 60 (sender common) is soundly connected to an earth point on the ENGINE BLOCK, not within the control panel and must be a sound electrical connection to the sender bodies. If you use PTFE insulating tape on the sender thread when using earth return senders, ensure you do not insulate the entire thread as this will prevent the sender body from being earthed via the engine block.

15.2 USING INSULATED RETURN (TWO WIRE) SENDERS.

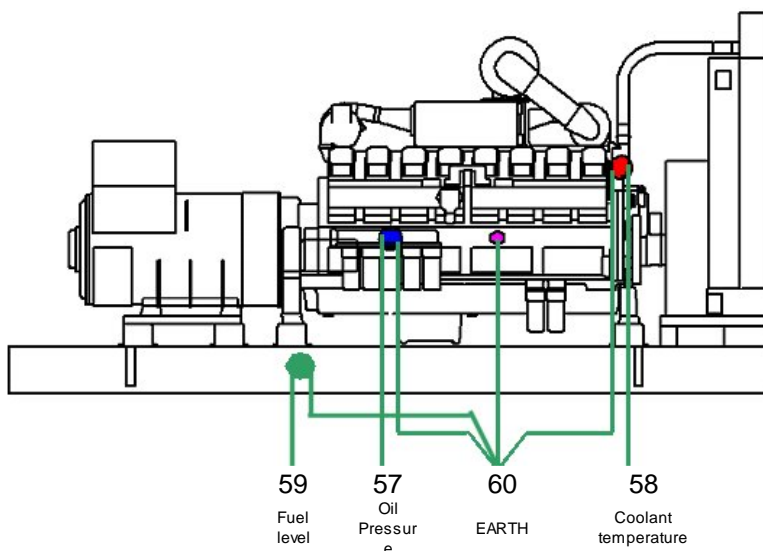

NOTE:- . It is important that terminal 60 (sender common) is soundly connected to an earth point on the ENGINE BLOCK, not within the control panel .

16 APPENDIX

16.1 5510 IDMT TRIPPING CURVES (TYPICAL)

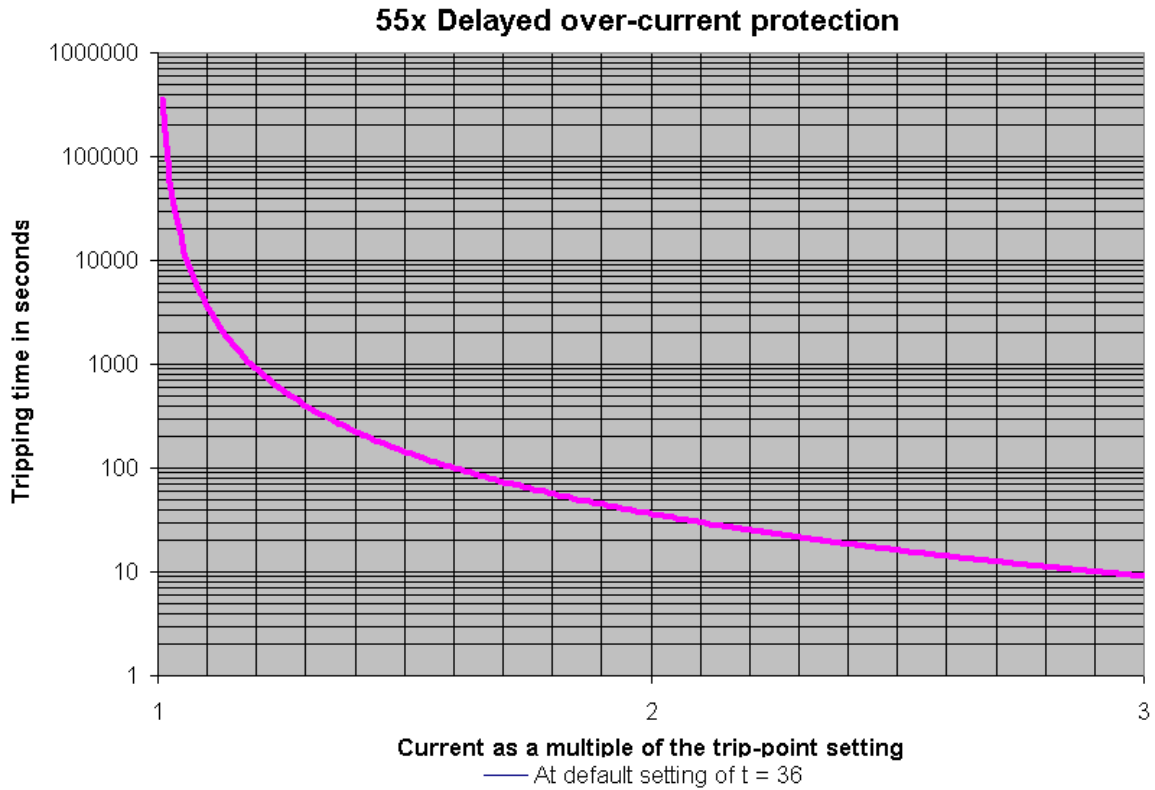

16.2 5510 SHORT CIRCUIT TRIPPING CURVES (TYPICAL)

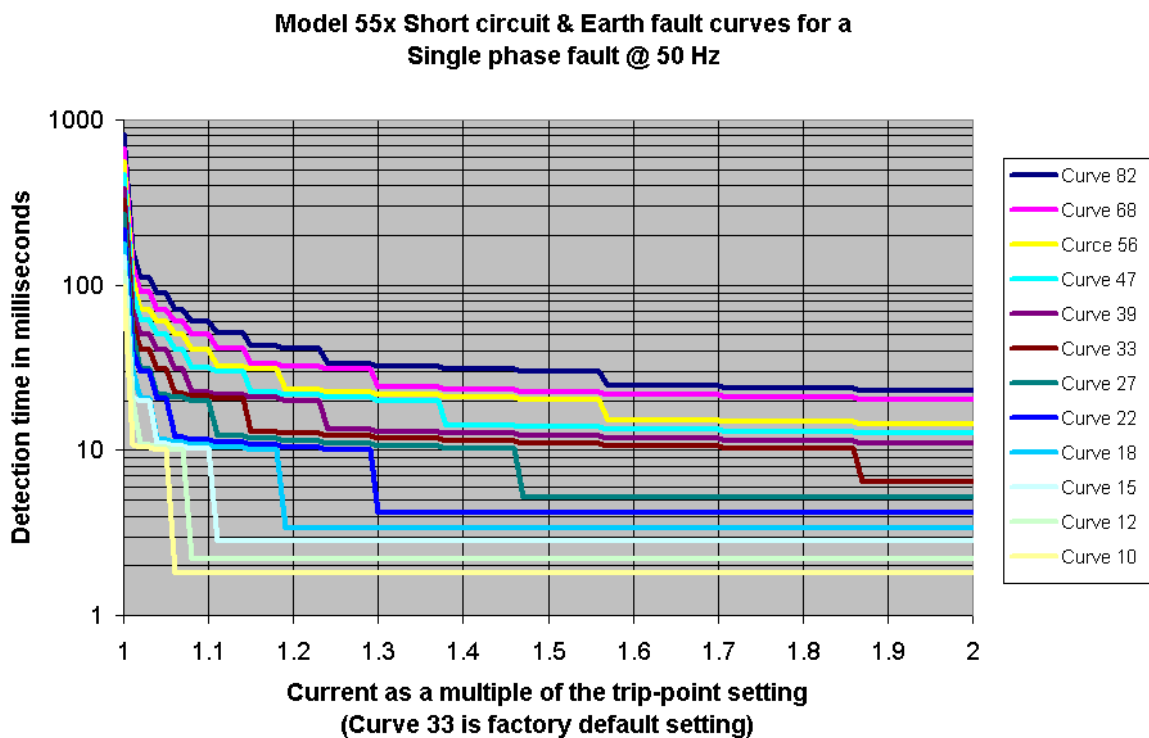

16.3 ACCESSORIES

16.3.1 OUTPUT EXPANSION

There are several methods of output expansion available for the 55xx range of modules: -

RELAY OUTPUT EXPANSION (157)

An expansion module is available, which connects to the configuration socket, and enables the 55xx to use eight additional relays, providing Volt-free contacts for customer connection. A maximum of two of these units can be used give 16 independent volt-free contacts.

The 157's need to be identified as module 'A' and module 'B'

Refer to technical data sheet on the 157 relay module for further details.

LED OUTPUT EXPANSION (548)

An expansion module is available, which connects to the configuration socket, and enables the 55xx to use the eight additional LED's on the 548 module, providing remote LED's indication. A maximum of two of these units can be used give 16 independent remote LED's.

The 548's need to be identified as module 'A' and module 'B'

Refer to technical data sheet on the 548 LED modules for further details.

It is possible to use a mix of 157 and 548 modules to give both relay and LED expansion if required.

16.3.2 INPUT EXPANSION (P130/P540/P541)

It is possible to increase the number of monitored inputs available by utilising either:

- DSE P130 input expansion.
- 540 / 541 Protection Expansion/Annunciator.

Please refer to the relevant product documentation for further details.

16.4 COMMUNICATIONS OPTION

16.4.1 DESCRIPTION

The 5xxx series configuration software allows the 5510 controller to communicate with a PC. The computer can be connected to the module either directly, via a modem (RS232)* or via an RS485 link**.

The operator is then able to remotely control the module, starting or stopping the generator, selecting operating modes, etc. The various operating parameters (such as output volts, oil pressure, etc.) on the remote generator can also be viewed.

The information contained in this manual should be read in conjunction with the appropriate module documentation. This manual only details the operation of the communications software and how it should be used. The operation of the module is detailed in its own relevant manual.

NOTE: - *If modem communications is a requirement, then it is important to order the correct 5510 module with the RS232 communications board fitted. This provides a 9-way D-type connector suitable for connection to the modem. Please refer to the *comms* section of this manual for details of how the system should be configured.

**If RS485 communications is required, then it is important to order the correct 5510 module with the RS485 communications board fitted. This provides a 3-way terminal block for connection of the RS485 link.

16.4.2 PC TO CONTROLLER (DIRECT) CONNECTION

To connect a 5510 to a modem the following items are required: -

- Any 5510 Module (RS232 or RS485)
- 5xxx series configuration software (Supplied on DSE software CD).
- P810 interface (USB or RS232 as required)

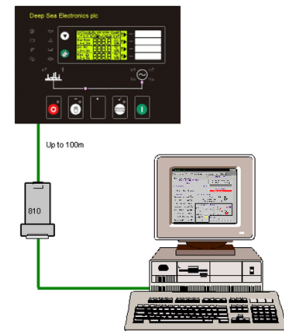

16.4.3 MODEM TO CONTROLLER CONNECTION

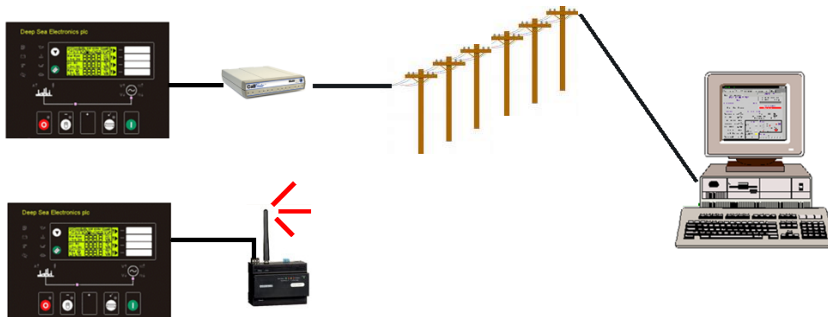

To connect a 5510 to a modem the following items are required: -

- 5510 Module with RS232 Communications Interface
- Compatible RS232 Modem (PSTN or GSM)
- Suitable connection leads
- Power supply for the modem
- 5xxx series configuration software (Supplied on DSE software CD).
- Access to a PSTN Line or GSM network.

CAUTION! - The modem must be powered from a suitably stabilised supply, preferably supplied with the modem (see below). Failure to ensure continuity of supply will result in communication difficulties at such times as Mains failure or during cranking. An

uninterruptible power supply arrangement is recommended (AC or DC depending on modem power requirement).

16.4.4 RS485 LINK TO CONTROLLER

The RS485 enabled 5510 modules are able to communicate with a PC or other RS485 enabled device over a standard RS485 connection. Typical uses of RS485 are:

- Direct connection to a remote PC running the Link5000 software. RS485 is capable of communication over a distance of 1.2km where suitable 120Ω RS485 cable is installed.
- Connection to a building management to allow mains, generator and engine parameters/alarm conditions to be displayed along with information from other devices (air conditioning, fire alarm system etc).

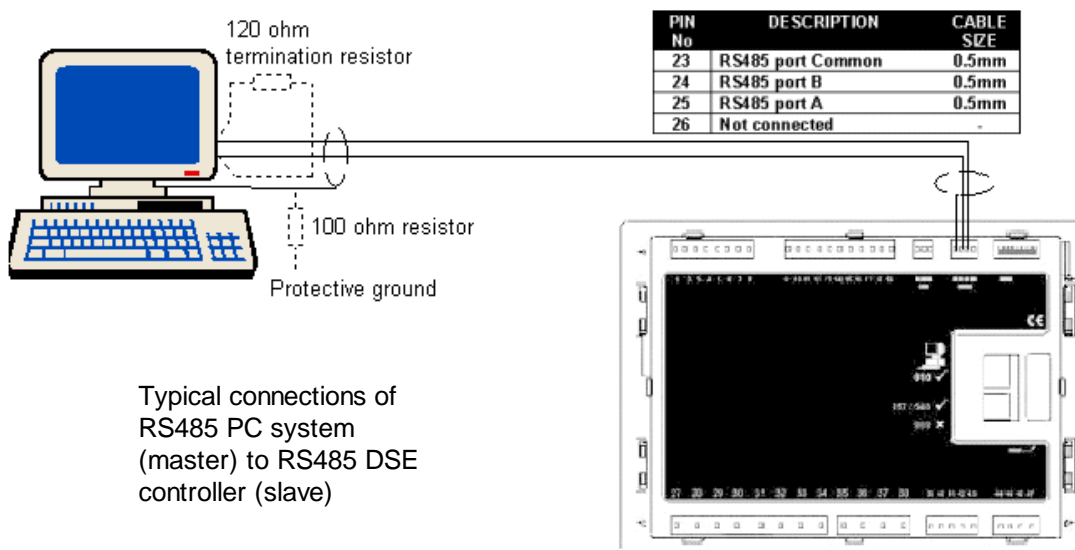

NOTE: - The RS485 system will comprise of one MODBUS master (typically a PC) and up to 31 MODBUS slaves. The 5510 modules are always MODBUS slave devices. To ensure correct operation a suitable 120Ω terminal resistor must be fitted to each end of the RS485 connection bus.

Caution! - The A and B lines of the 485 network should be terminated at each end with a 120Ω resistor.

Some RS485 devices (PC cards in particular) are already fitted with a terminating resistor. However if they are not installed as an 'end of line' device then such terminating resistors must be removed. Other RS485 devices may be fitted with a 'switchable' resistor, again this must be switched out if the device is not installed as an 'end of line' device.

TYPICAL BUILDING MANAGEMENT SCHEME USING RS485 MONITORING

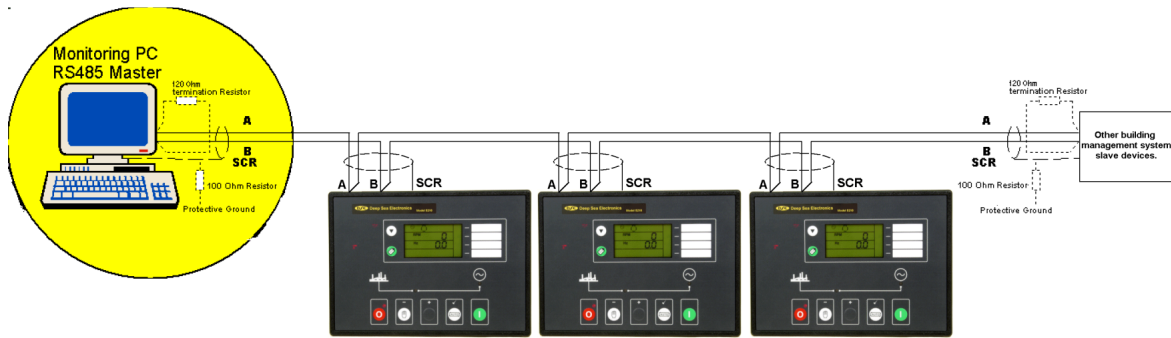

CAUTION! -. RS485 cabling must be 120Ω impedance cable, specified for use with RS485. 120Ω terminating resistors must be fitted to the first and last devices on the bus. Some PC RS485 cards are already fitted with this resistor, and in this case should not be fitted externally. If in doubt, consult the supplier of your PC RS485 card.
 If the 5510 controller is the 'last' device on the bus, then it's RS485 connection must be suitably terminated with a 120Ω resistor as detailed in the specification laid out in the RS485 standard.

Recommended cable BELDEN 9841 120Ω RS485 cable.
 DSE part number 016-030.

NOTE: - The RS485 output uses 'MODBUS' protocol. It is possible to use third party software to monitor and control the 5510 module via this protocol.
 Please refer to Deep Sea Electronics Plc for details.

16.4.5 MODBUS™

The RS485 output uses Modbus™ communications protocol. This uses a master-slave technique to communicate. Only the Master can initiate a packet transaction, called a 'query'. When appropriate the slave (5510 Module) responds to the query and provides the information requested by the master.

All supported data can be read and written as specified in the register table (documentation is available from Deep Sea Electronics Plc.).

When the 5510 Module receives a query it will respond by either supplying the requested register data or performing the requested action. A slave device (the 5510 module) will never initiate communications on the Modbus™ link. The 5510 can only be configured as a slave device. The Master can only query individual slaves. Refer to the Modbus™ protocol document for more details.

Refer to the Link5000plus Manual for further details on communications expansion.

NOTE:- 5560 controller only available with RS485 communications.

16.5 ENCLOSURE CLASSIFICATIONS

IP CLASSIFICATIONS

BS EN 60529 Degrees of protection provided by enclosures

First Digit	Second digit
Protection against contact and ingress of solid objects 0 No protection	Protection against ingress of water 0 No protection
1 Protected against ingress solid objects with a diameter of more than 50 mm. No protection against deliberate access, e.g. with a hand, but large surfaces of the body are prevented from approach.	1 Protection against dripping water falling vertically. No harmful effect must be produced (vertically falling drops).
2 Protected against penetration by solid objects with a diameter of more than 12 mm. Fingers or similar objects prevented from approach.	2 Protection against dripping water falling vertically. There must be no harmful effect when the equipment (enclosure) is tilted at an angle up to 15° from its normal position (drops falling at an angle).
3 Protected against ingress of solid objects with a diameter of more than 2.5 mm. Tools, wires etc. with a thickness of more than 2.5 mm are prevented from approach.	3 Protection against water falling at any angle up to 60° from the vertical. There must be no harmful effect (spray water).
4 Protected against ingress of solid objects with a diameter of more than 1 mm. Tools, wires etc. with a thickness of more than 1 mm are prevented from approach.	4 Protection against water splashed against the equipment (enclosure) from any direction. There must be no harmful effect (splashing water).
5 Protected against harmful dust deposits. Ingress of dust is not totally prevented but the dust must not enter in sufficient quantity to interfere with satisfactory operation of the equipment. Complete protection against contact.	5 Protection against water projected from a nozzle against the equipment (enclosure) from any direction. There must be no harmful effect (water jet).
6 Protection against ingress of dust (dust tight). Complete protection against contact.	6 Protection against heavy seas or powerful water jets. Water must not enter the equipment (enclosure) in harmful quantities (splashing over).

NEMA CLASSIFICATIONS

 **NOTE: - There is no direct equivalence between IP / NEMA ratings. IP figures shown are approximate only.**

1 IP30	Provides a degree of protection against contact with the enclosure equipment and against a limited amount of falling dirt.
2 IP31	Provides a degree of protection against limited amounts of falling water and dirt.
3 IP64	Provides a degree of protection against windblown dust, rain and sleet; undamaged by the formation of ice on the enclosure.
3R IP32	Provides a degree of protection against rain and sleet; undamaged by the formation of ice on the enclosure.
4 (X) IP66	Provides a degree of protection against splashing water, windblown dust and rain, hose directed water; undamaged by the formation of ice on the enclosure. (Resist corrosion).
12/12K IP65	Provides a degree of protection against dust, falling dirt and dripping non corrosive liquids.
13 IP65	Provides a degree of protection against dust and spraying of water, oil and non corrosive coolants.

16.6 IEEE C37.2 STANDARD ELECTRICAL POWER SYSTEM DEVICE FUNCTION NUMBERS

The DSE 5510 contains many protection devices and functions, which are listed in detail in the following sections.

Functions and protections provided corresponding to IEEE C37.2 (1996) system device numbers are listed below.

Overall the 5510 is designated as 11 - *Multifunction device* and includes the following protections and functions:

Device	Description	
2	time delay starting or closing relay	A device that functions to give a desired amount of time delay before or after any point of operation in a switching sequence or protective relay system, except as specifically provided by device functions 48, 62, 79, and 82.
3	checking or interlocking relay	A device that operates in response to the position of one or more other devices or predetermined conditions in a piece of equipment or circuit, to allow an operating sequence to proceed, or to stop, or to provide a check of the position of these devices or conditions for any purpose.
5	stopping device	A control device used primarily to shut down equipment and hold it out of operation. (This device may be manually or electrically actuated, but it excludes the function of electrical lockout [see device function 86] on abnormal conditions.)
12	overspeed device	A device, usually direct connected, that operates on machine overspeed.
14	underspeed device	A device that functions when the speed of a machine falls below a predetermined value.
15	speed or frequency matching device	A device that functions to match and hold the speed or frequency of a machine or a system equal to, or approximately equal to, that of another machine, source, or system.
18	accelerating or decelerating device	A device that is used to close or cause the closing of circuits that are used to increase or decrease the speed of a machine.
25	synchronizing or synchronism-check relay	A synchronizing device produces an output that causes closure at zero-phase angle difference between two circuits. It may or may not include voltage and speed control. A synchronism-check relay permits the paralleling of two circuits that are within prescribed limits of voltage magnitude, phase angle, and frequency.
27	undervoltage relay	A device that operates when its input voltage is less than a predetermined value.
30	annunciator relay	A non-automatically reset device that gives a number of separate visual indications upon the functioning of protective devices and that may also be arranged to perform a lockout function.
31	separate excitation device	A device that connects a circuit, such as the shunt field of a synchronous converter, to a source of separate excitation during the starting sequence.
32	directional power relay	A device that operates on a predetermined value of power flow in a given direction such as reverse power flow resulting from the motoring of a generator upon loss of its prime mover.
46	reverse-phase or phase-balance current relay	A device in a polyphase circuit that operates when the polyphase currents are of reverse-phase sequence or when the polyphase currents are unbalanced or when the negative phase-sequence current exceeds a preset value.
48	incomplete sequence relay	A device that generally returns the equipment to the normal or off position and locks it out if the normal starting, operating, or stopping sequence is not properly completed within a predetermined time.
50	instantaneous overcurrent relay	A device that operates with no intentional time delay when the current exceeds a preset value.
51	ac time overcurrent relay	A device that functions when the ac input current exceeds a predetermined value, and in which the input current and operating time are inversely related through a substantial portion of the performance range.

Device	Description
52 ac circuit breaker	A device that is used to close and interrupt an ac power circuit under normal conditions or to interrupt this circuit under fault or emergency conditions.
54 turning gear engaging device	A device electrically operated, controlled, or monitored that functions to cause the turning gear to engage (or disengage) the machine shaft.
55 power factor relay	A device that operates when the power factor in an ac circuit rises above or falls below a predetermined value.
59 overvoltage relay	A device that operates when its input voltage exceeds a predetermined value.
62 time-delay stopping or opening relay	A device that imposes a time delay in conjunction with the device that initiates the shutdown, stopping, or opening operation in an automatic sequence or protective relay system.
63 pressure switch	A device that operates at a given pressure value or at a given rate of change of pressure.
69 permissive control device	A device with two-positions that in one position permits the closing of a circuit breaker, or the placing of a piece of equipment into operation, and in the other position, prevents the circuit breaker or the equipment from being operated.
71 level switch	A device that operates at a given level value, or on a given rate of change of level.
74 alarm relay	A device other than an annunciator, as covered under device function 30, that is used to operate, or that operates in connection with, a visual or audible alarm.
78 phase-angle measuring relay	A device that functions at a predetermined phase angle between two voltages, between two currents, or between voltage and current.
81 frequency relay	A device that responds to the frequency of an electrical quantity, operating when the frequency or rate of change of frequency exceeds or is less than a predetermined value.
83 automatic selective control or transfer relay	A device that operates to select automatically between certain sources or conditions in equipment or that performs a transfer operation automatically.
86 lockout relay	A device that trips and maintains the associated equipment or devices inoperative until it is reset by an operator, either locally or remotely.
90 regulating device	A device that functions to regulate a quantity or quantities, such as voltage, current, power, speed, frequency, temperature, and load, at a certain value or between certain (generally close) limits for machines, tie lines, or other apparatus.

16.7 SYNCHRONISING NOTES

Optionally, the 5510 controller can be configured to forward synchronise, volts match and parallel with the mains supply. This facility can be used to supply a fixed amount of power to the load and/or mains supply or share load with other 5510 or 550 enabled generator systems.

16.7.1 CHECK SYNC

(If enabled)

The module will control the operation of the load-switching device to allow parallel operation with the mains / bus supply only when the two supplies are in synchronism.

16.7.2 AUTO SYNC

(If enabled)

The module provides control signals to the Engine Governor and the Alternator AVR to control the speed and voltage output from the generating set.

Refer to the 5xxx software manual for further details.

16.7.3 LOAD CONTROL

(If enabled)

The module features all the functions associated with the Check sync and auto sync features and in addition, it provides control signals to the Engine Governor and the Alternator AVR while in parallel with the mains (utility) or generator bus.

These functions can be used to provide peak shaving and load sharing with other 5510 enabled generating set systems.

Refer to the 5xxx software manual for further details.

16.7.4 TYPICAL LOAD SHARING SYSTEM

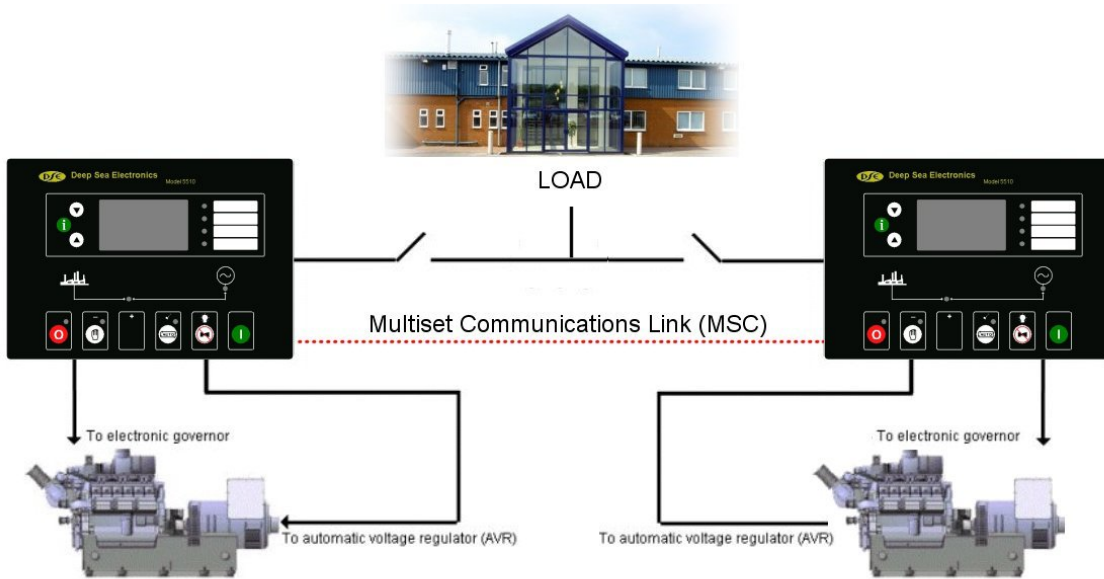

NOTE:- Up to 16 sets can be connected in parallel in this way, sharing kW load (and kVAr load if required) utilising the multi-set communications link (MSC).

16.7.5 TYPICAL PEAK SHAVING SYSTEM

(Generator provides a fixed amount of power)

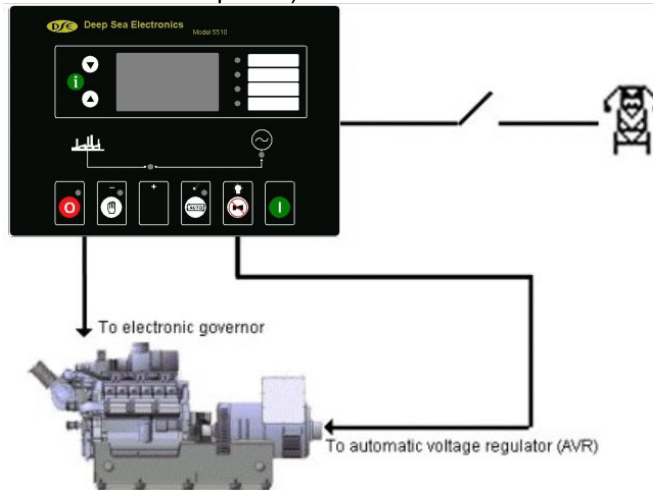

For further details on this subject you are referred to the Deep Sea Electronics Guide to Synchronising and Load Sharing. This document includes diagrams to show connections to many of the most common electronic governors and interfaces.

Utilising the 5560 mains controller, the 5510 can be incorporated into a true peak lopping system with multiple generator sets and multiple mains supplies and loads. Please consult Deep Sea Electronics for further information.