

GENERAL NOTES -
 GENSET RATING
 1000 KVA
 800 KW
 VOLTAGE 220V
 CURRENT 2624A

ENGINE - CUMMINS QSK23 G3
 ALTERNATOR - NEWAGE HCl 634G
 RADIATOR - BEARWARD 56/330U001

TOTAL GENSET WEIGHT (INCLUDING FULL FUEL TANK) - 6600 KG
 TOTAL CONTAINER WEIGHT - 5200 KG

NOISE LEVEL - 85 dBA MEAN @ 1M ASSUMING FREE FIELD CONDITIONS WITH BACKGROUND NOISE NON-CONTRIBUTORY AND FOR THE GENSET TO BE RUNNING AT 100% OF THE STANDBY RATING.

NOTE - ALL DIMENSIONS ARE ASSUMED AND ARE TO BE CONFIRMED BY CONTAINER MANUFACTURER THAT THEY ARE FEASIBLE IN REGARDS TO CONTAINER CONSTRUCTION DESIGN. THE CONTAINER CONSTRUCTION ON THIS DRAWING IS ASSUMED AND WILL NEED TO BE CONFIRMED BY CONTAINER MANUFACTURER. THIS ESPECIALLY APPLIES TO BREAKER BOX OPENINGS.
 THE EXHAUST SILENCER ENVELOPE SHOWN IS SUBJECT TO FINAL DESIGN BY CONTAINER MANUFACTURER.

READ DRAWING IN CONJUNCTION WITH CONTAINER SPEC.SEC-SC01-A

NOTE:-
 FOR INTERNAL CONTAINER ARRANGEMENT SEE DRAWING N' BCC800P-GL02-A1-A

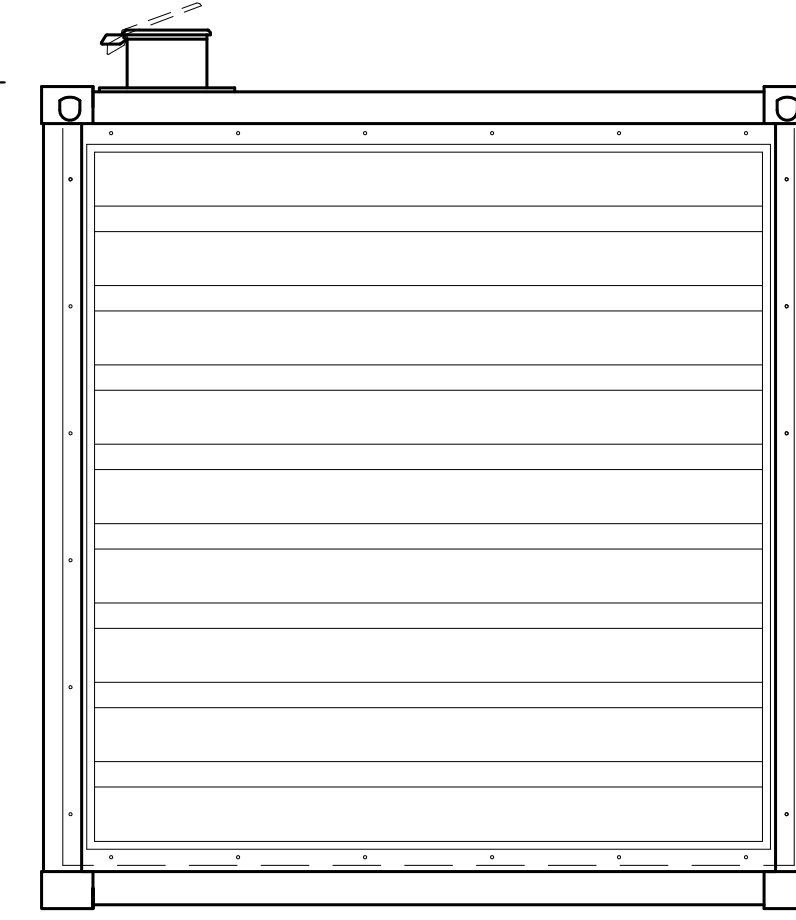
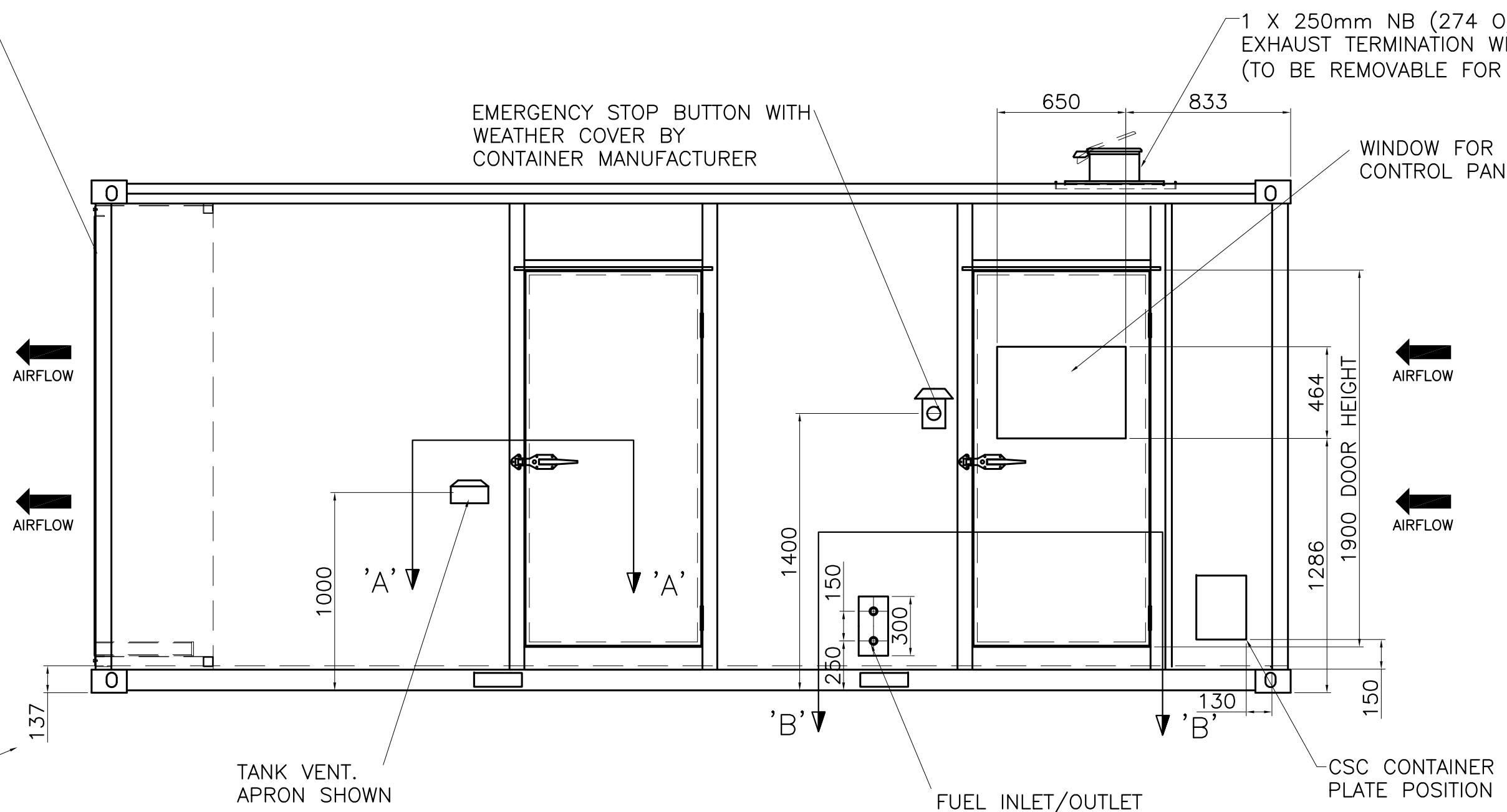
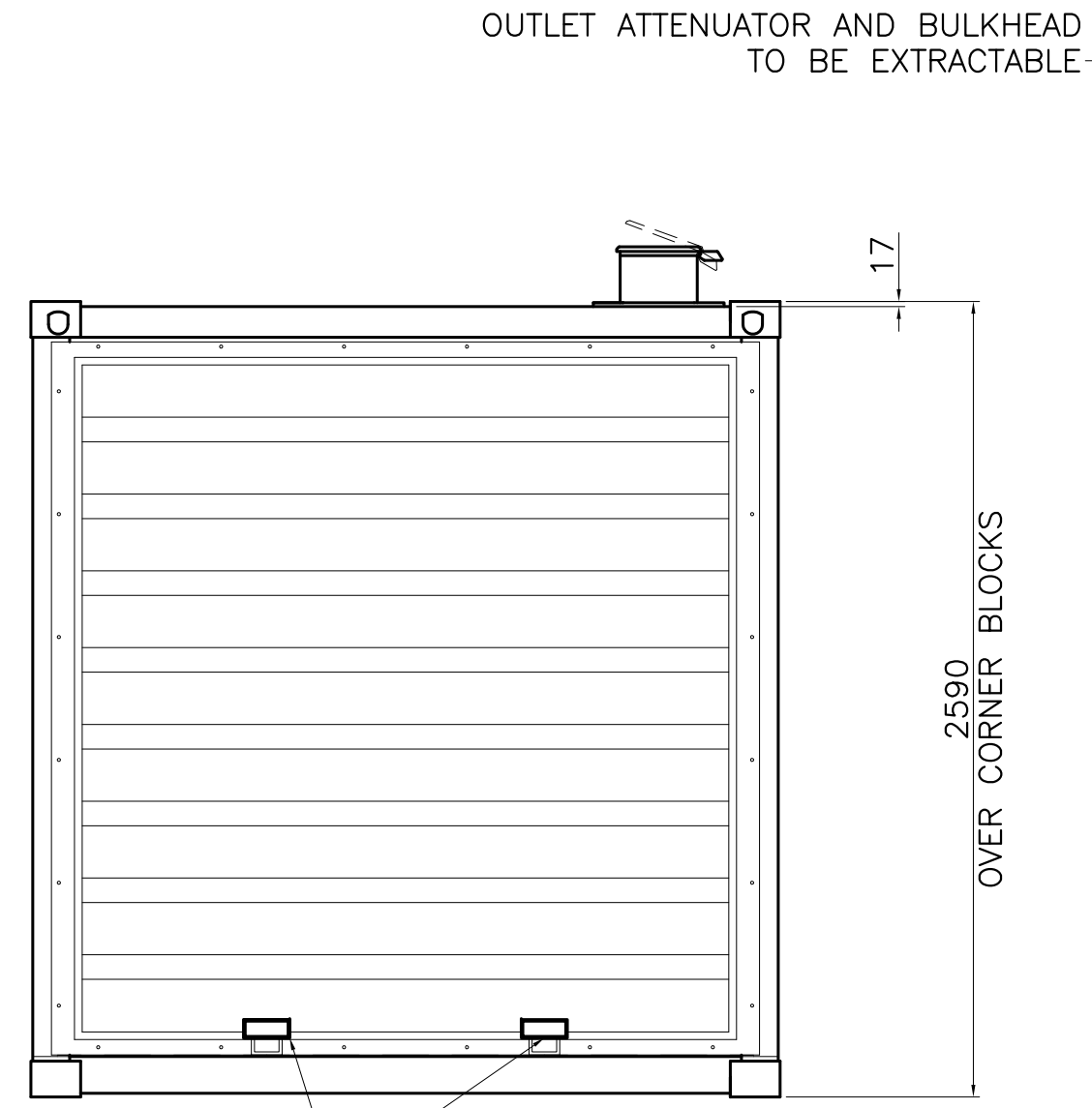
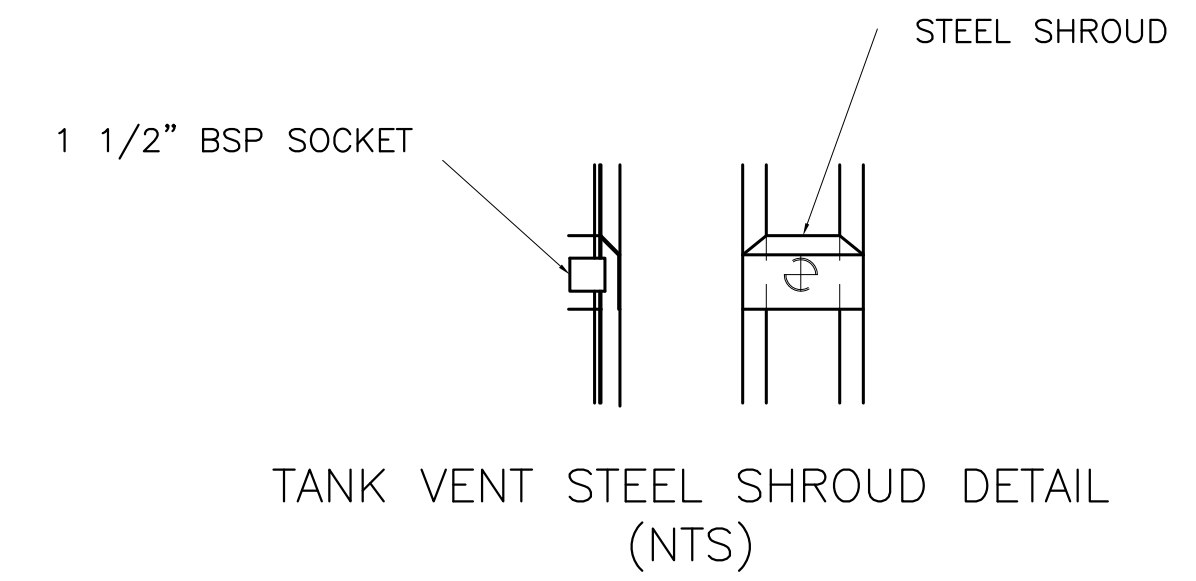
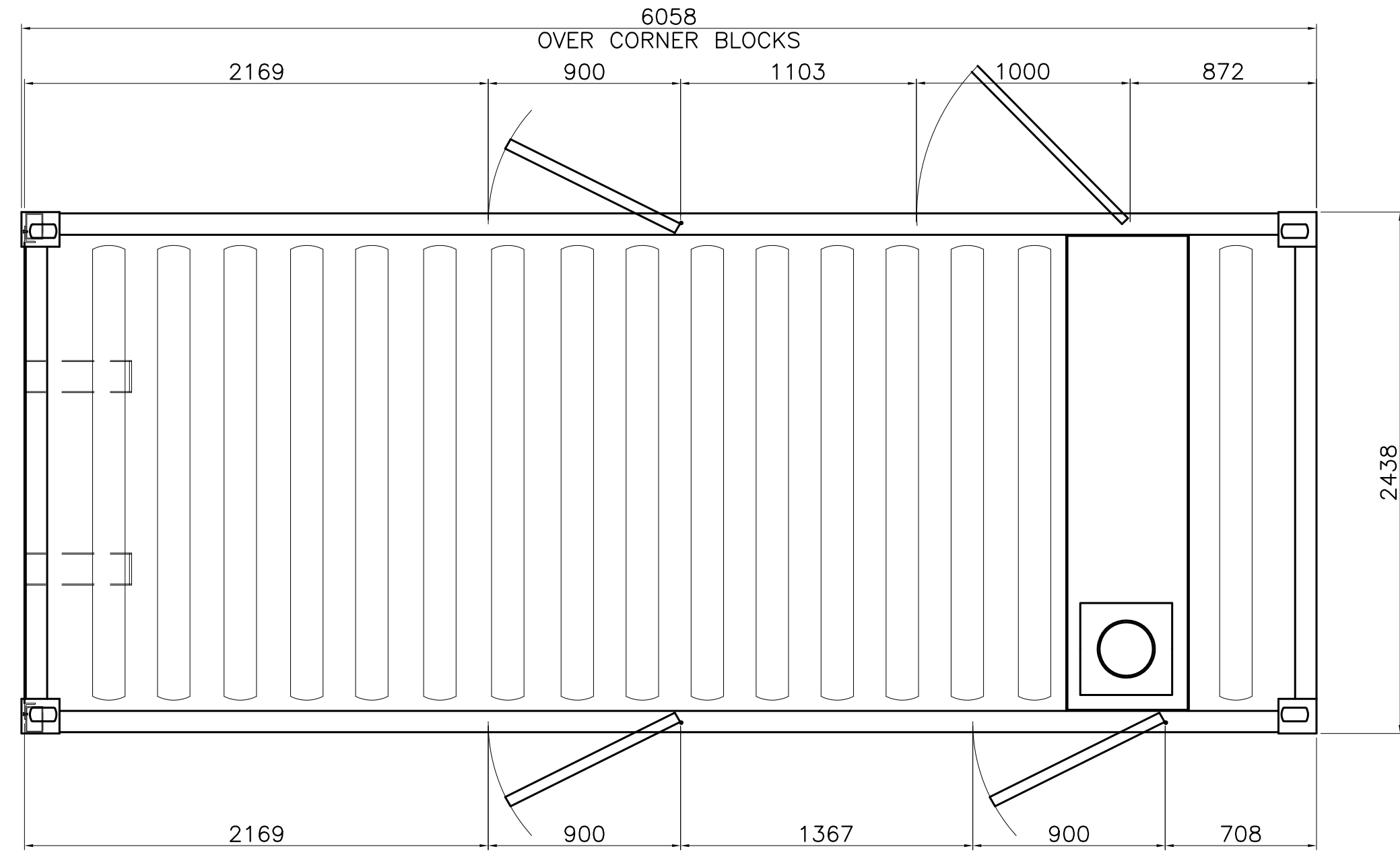

150mm x 60mm FORK POCKETS AS LOW AS POSSIBLE IN ATTENUATOR. POCKETS TO BE @ 900 CTRS. ATTENUATOR SUPPORT SECTION WELDED TO UNDERNEATH.

ASSUMED DIMENSION FROM BOTTOM OF BASE FRAME TO BOTTOM OF CONTAINER

INTERNAL LINING IN THESE AREAS TO BE SECURED & OMITTED. POCKET AREAS TO BE THE NEAREST 2 FULL INVERT PROFILE TO THE DOOR

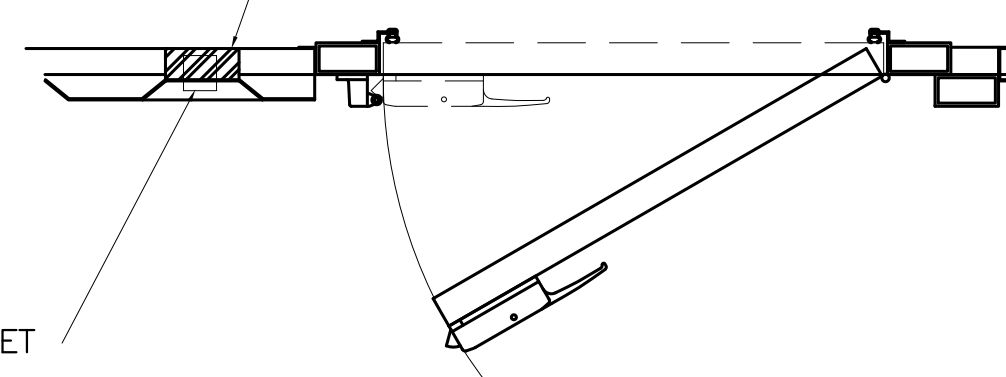

SECTION 'A'-'A' TANK VENT DETAIL (NTS)

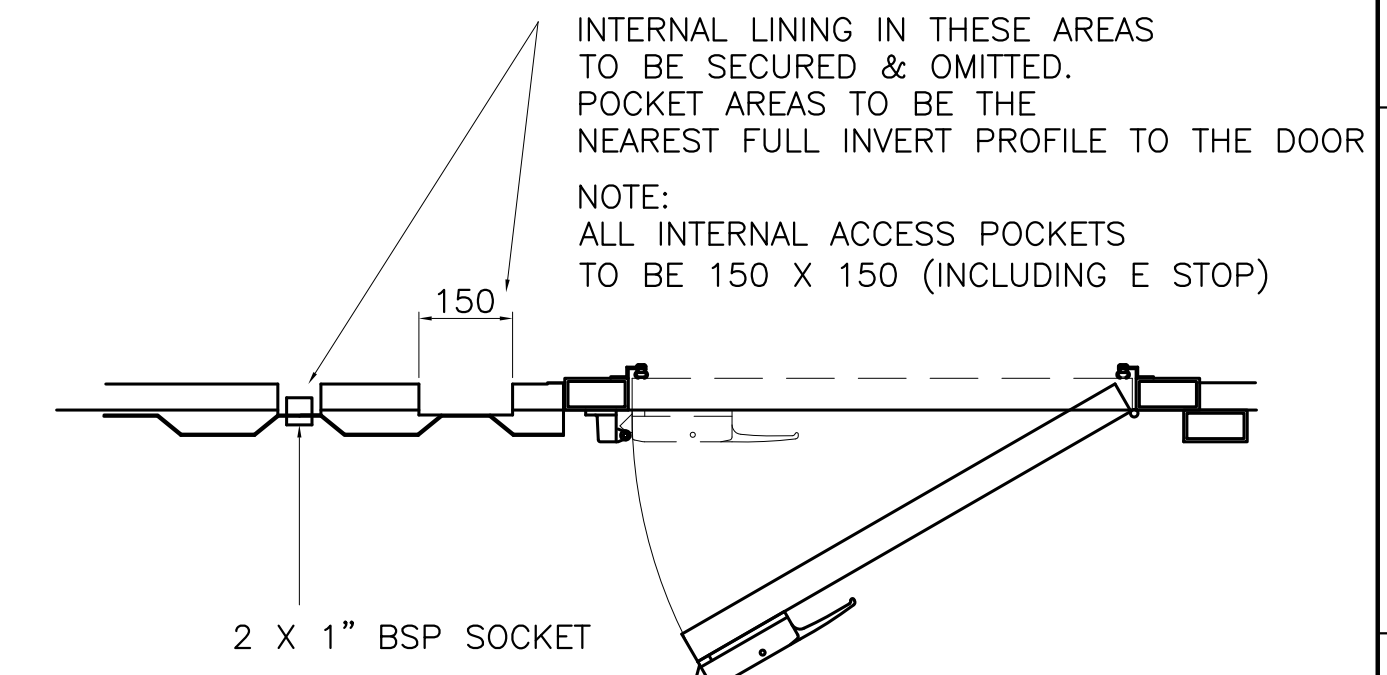
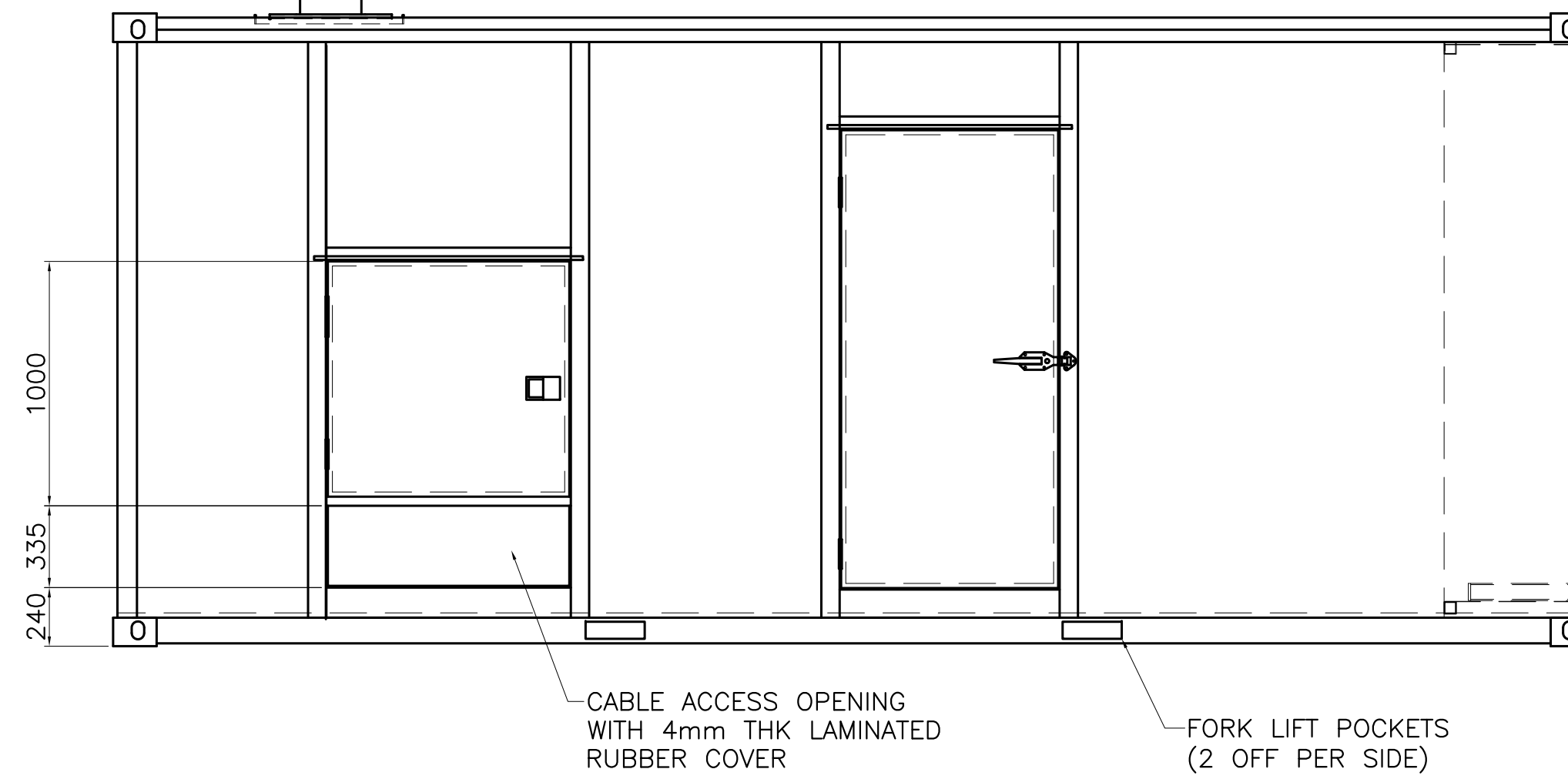

SECTION 'B'-'B' FUEL INLET & ELECTRICAL SOCKET DETAIL (NTS)

No.	ALTERATIONS	CHK'D	DATE

NOTES - MECHANICAL
 TOLERANCES:
 GENERAL TOLERANCE + / - 5MM
 FABRICATION + / - 3MM
 HOLE CENTRES + / - 1MM
 OTHER TOLERANCES AS STATED WHERE REQUIRED

DO NOT SCALE IF IN DOUBT ASK

THIRD ANGLE PROJECTION

TITLE: GENSET CONTAINER ARRANGEMENT	
CLIENT: BROADCASTCROWN LTD	
SITE: -	
W.O. No.: -	ENGINEER: DWM
TYPE: BCC800P/880S	DRAWN BY: R/JW
SCALE: NTS	DATE: MAY, '10
TOTAL No. OF SHEETS (1 - 999)	
DRAWING NO.	ISSUE
BCC800S-AC02	A

broadcrown
 Broadcrown Limited (Group Headquarters)
 Airfield Industrial Estate, Hixon, Stafford,
 ST18 0PF, United Kingdom.
 tel: +44 (0) 1889 272200
 www.broadcrown.com