

GENSET DETAILS—  
 ENGINE: CUMMINS QST30 G5  
 ALTERNATOR: NEWAGE HCI 634J (SINGLE BEARING)  
 RADIATOR: BEARWARD 5684200000  
 AV MOUNTS: FARRAT ISOLATOR RM SERIES  
 FRONT ENGINE FEET: AVM-R12555BN6  
 REAR ENGINE AND ALTERNATOR FEET: AVM-R10055BN7  
 OUTPUT: 1138 kVA @ 1800 RPM (PRIME RATING)  
 OUTPUT: 1250 kVA @ 1800 RPM (STANDBY RATING)  
 WEIGHTS:—  
 ENGINE: 3012 KG DRY, 3112 KG WET  
 ALTERNATOR: 2268 KG  
 RADIATOR: 830 KG DRY, 1065 WET  
 BASEFRAME: 1020 KG

BASIC GENERATOR WEIGHT: 7230 KG (DRY), 7565 KG (WET)  
 CONTROL PANEL/BREAKER BOX: 55 KG

COLOURS:—  
 ENGINE:— MAIZE YELLOW  
 BASEFRAME, ALTERNATOR & RADIATOR:— SEMI GLOSS BLACK

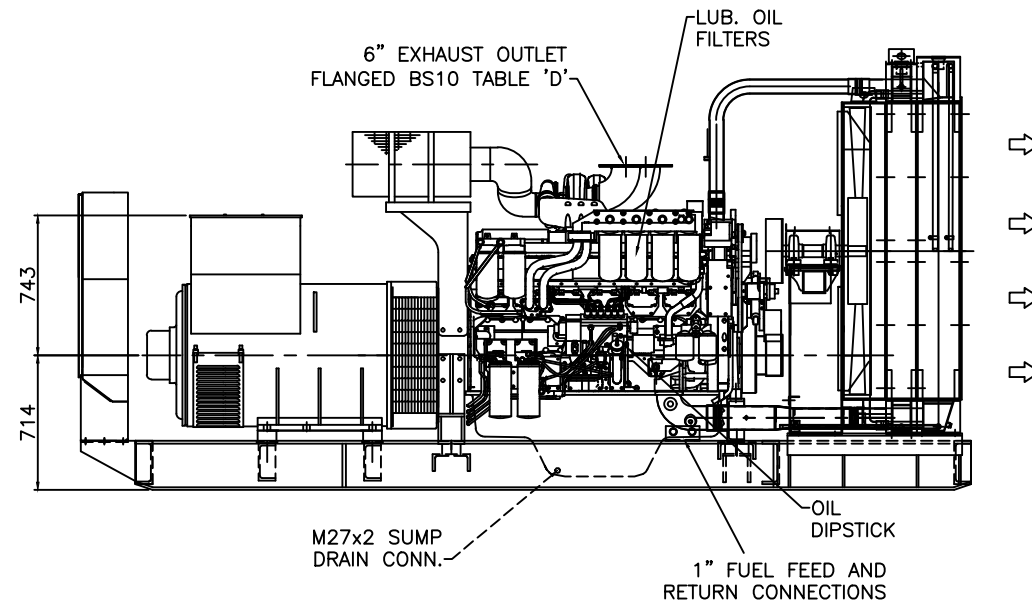
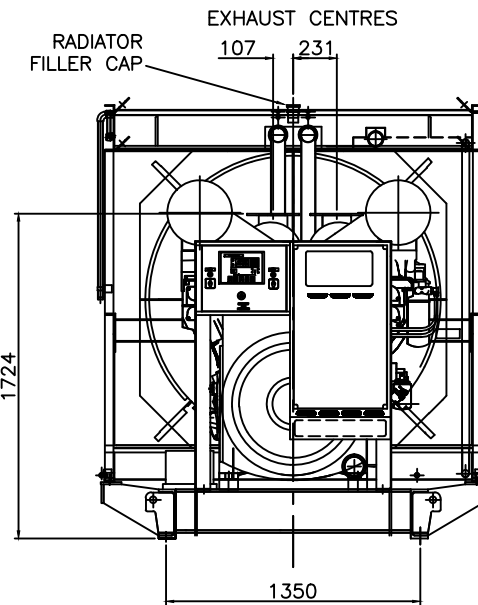
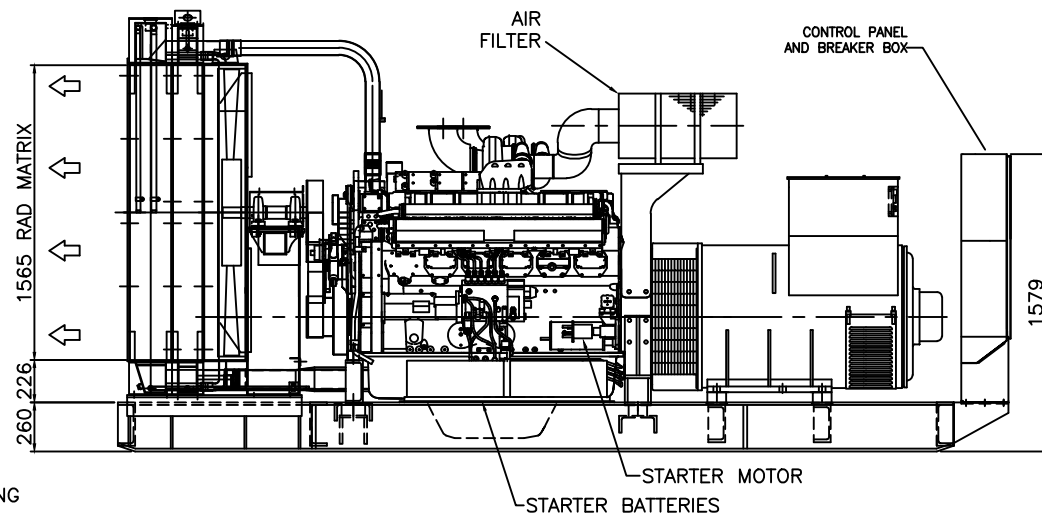
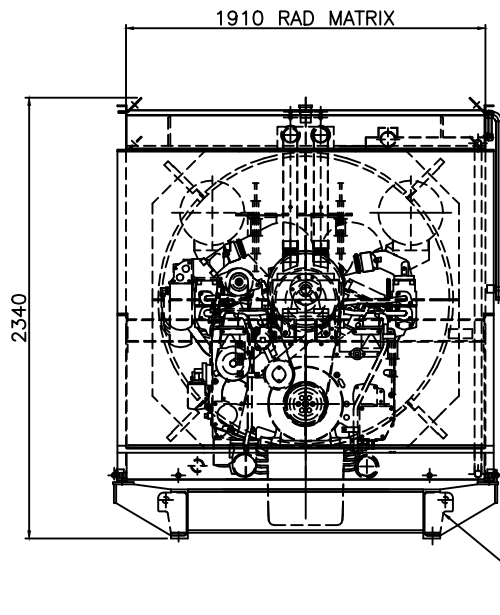
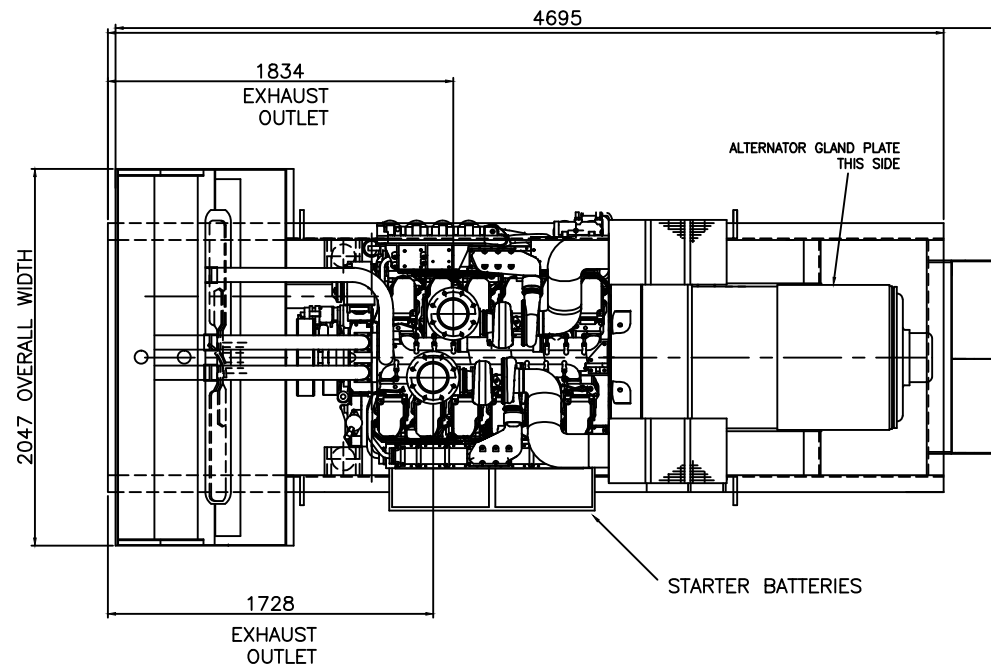

| No. | ALTERATIONS | CHK'D DATE |
|-----|-------------|------------|
|     |             |            |

NOTES - MECHANICAL

TOLERANCES:  
 GENERAL TOLERANCE + / - 5mm  
 FABRICATION + / - 3mm  
 HOLE CENTRES + / - 1mm  
 OTHER TOLERANCES AS STATED WHERE REQUIRED

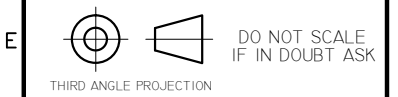

NOTES - ELECTRICAL

CABLE SIZE: 1.5MM UNLESS OTHERWISE STATED  
 CABLE COLOURS  
 DC CONTROL: VIOLET  
 DC POWER: POSITIVE BROWN, NEGATIVE BLUE  
 AC POWER SINGLE PHASE: LIVE BROWN, NEUTRAL BLUE  
 AC POWER THREE PHASE: L1 BROWN, L2 BLACK, L3 GREY, NEUTRAL BLUE  
 AC CONTROL: BLACK

|           |                             |       |          |
|-----------|-----------------------------|-------|----------|
| TITLE:    | GEN-SET GENERAL ARRANGEMENT |       |          |
| CLIENT:   | BROADCROWN INC              |       |          |
| SITE:     |                             |       |          |
| W.O. No.: | ENGINEER:                   | SKM   |          |
| TYPE:     | DRAWN BY:                   | SKM   |          |
| SCALE:    | NTS                         | DATE: | 28.09.07 |

|                               |                   |
|-------------------------------|-------------------|
| TOTAL No. OF SHEETS (1 - 999) | 1                 |
| DRAWING NO.                   | BCC 1000S-GA01-A1 |
| ISSUE                         | A                 |

**broadcrown**  
 Broadcrown Ltd, Airfield Industrial Estate  
 Hixon, Stafford, Staffs ST18 0PF, England  
 tel: +44 (0) 1889 272200  
 email: info@broadcrown.co.uk  
 www.broadcrown.com