

DETAIL B

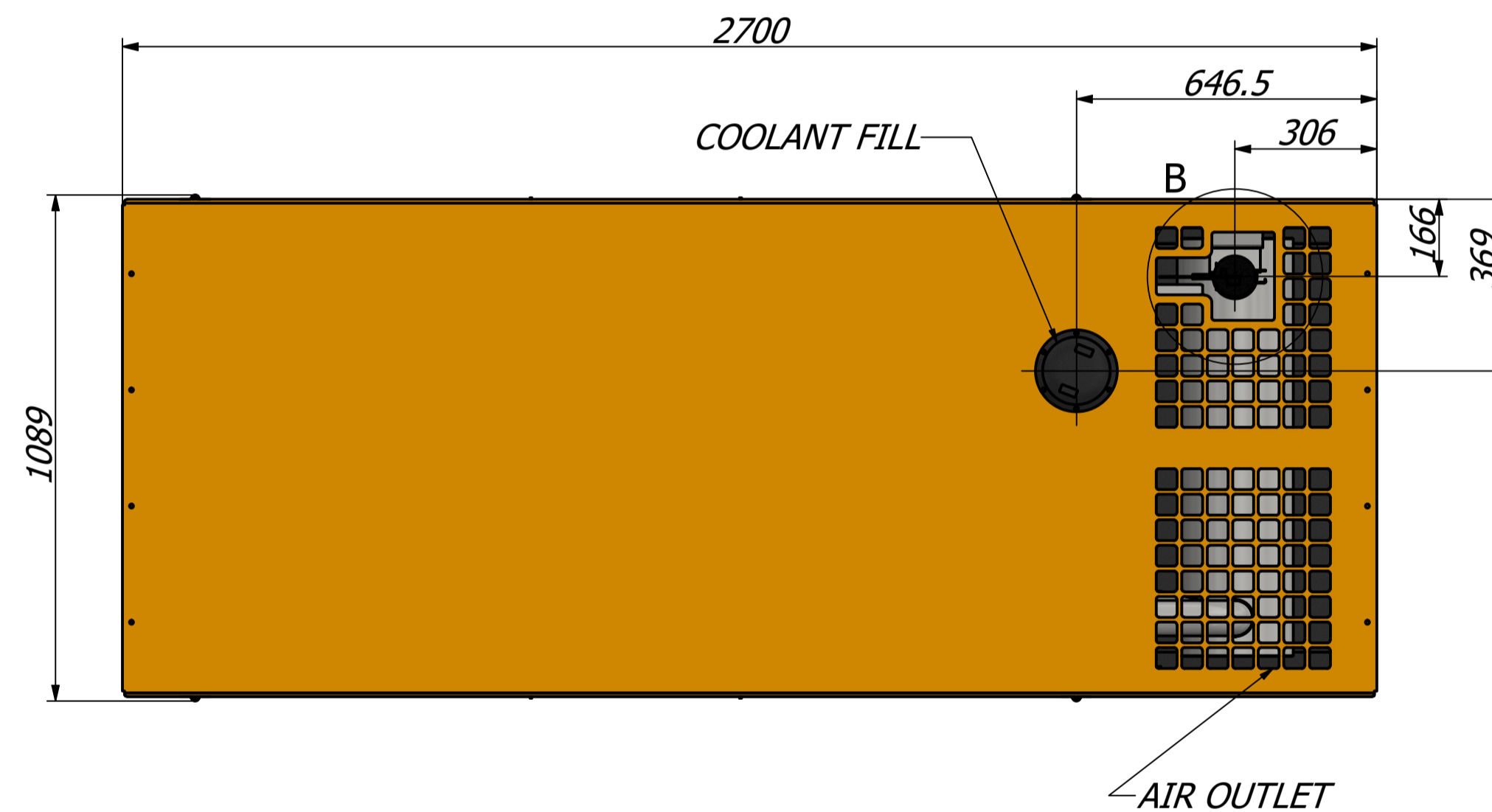

SECTION A-A

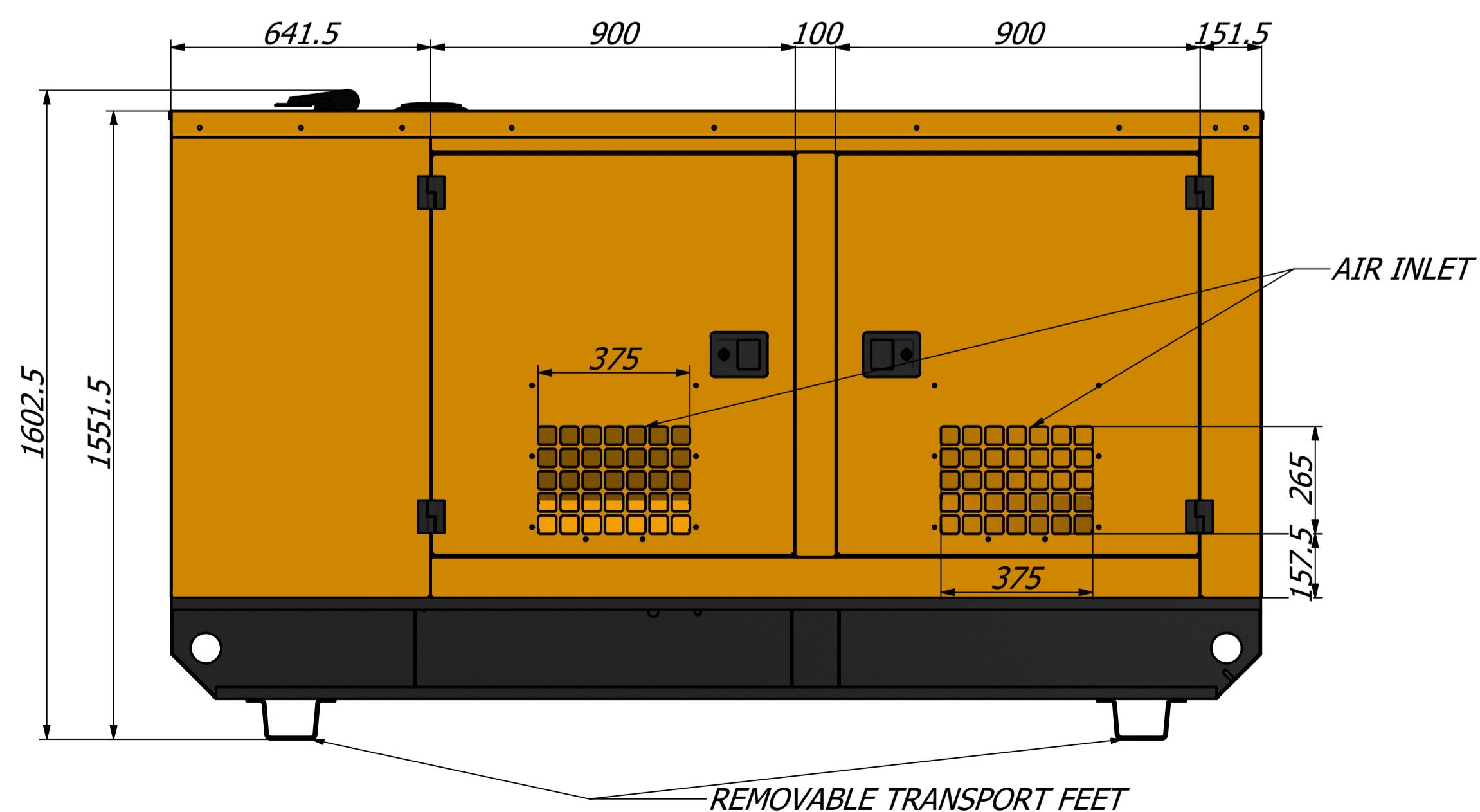
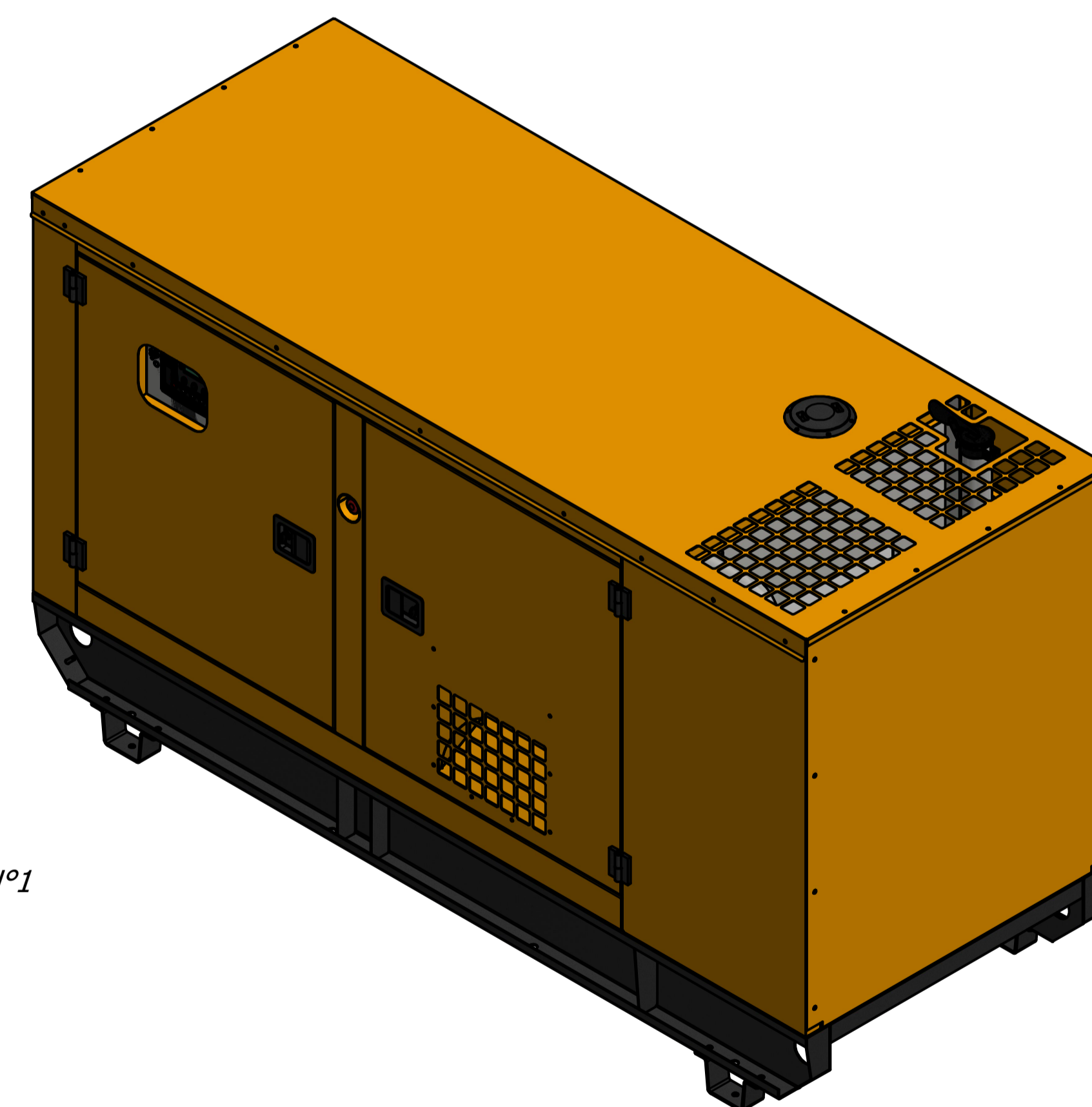
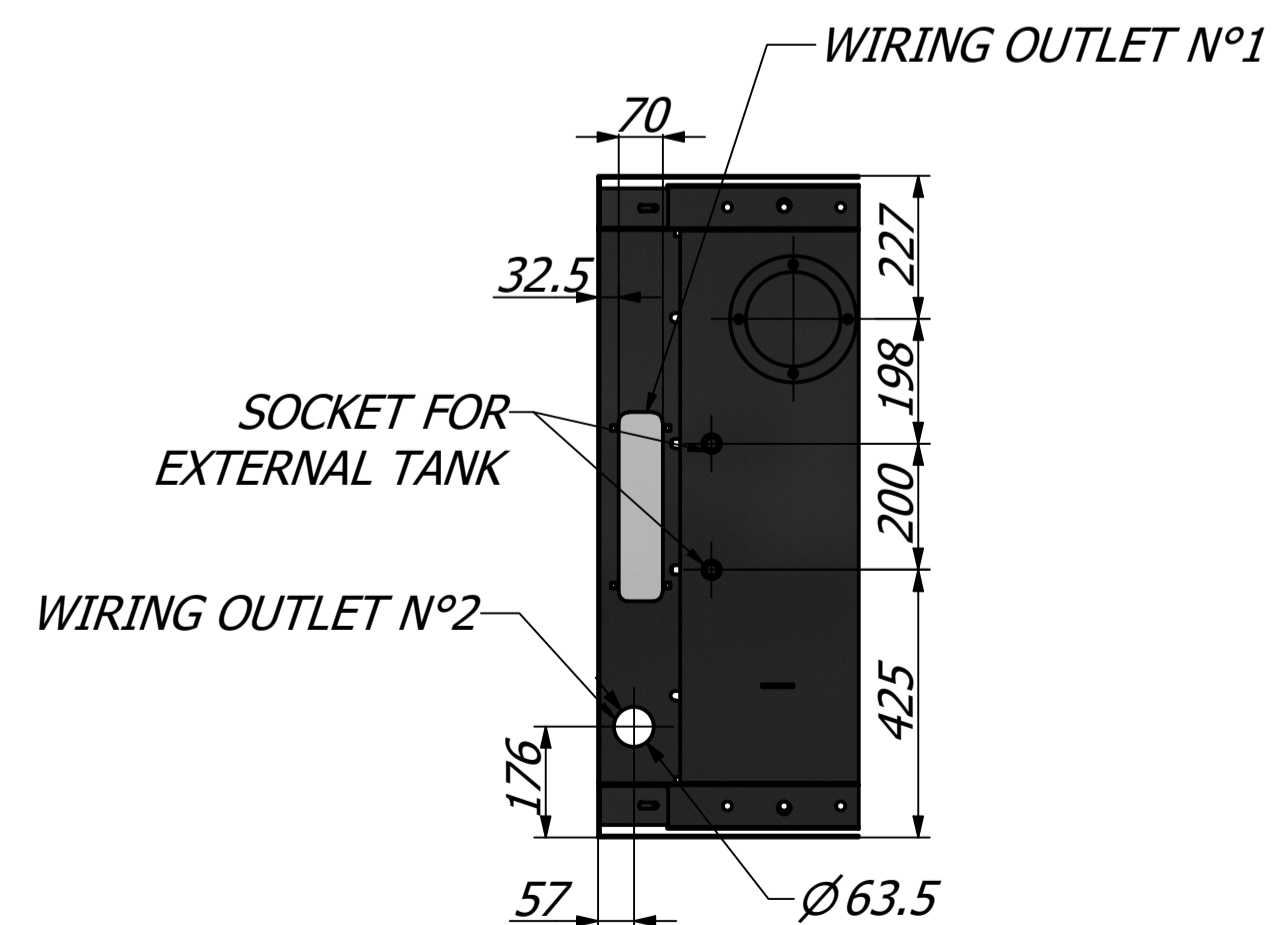

NOTES:

- 1.- GENSET MODEL: GPM-P68-60T3/GPM-P82-60T3
- 2.- ENGINE: PERKINS 1104D-E44TG1 EPA/ 1104D-E44TAG1 EPA
- 3.- ALTERNATOR: STANFORD UCI 224F/ UCI 224G
- 4.- FUEL TANK USABLE CAPACITY: 72 Gal. (273L)
- 5.- AIR INLET: REAR/ SIDE
- 6.- AIR OUTLET: TOP (ROOF)
- 7.- EXHAUST GASES OUTLET: TOP W/ RAIN CAP (Ø3")

MATERIAL: STEEL		TITLE: GENERAL DRAWING	
STANDARD: SEE NOTES		DIESEL GENERATOR	
PROJECT: GPM-P68-60T3/GPM-P82-60T3		REFERENCE: -	
SCALE: S/E	GENERAL TOLERANCES	RESPONSIBLES	PROTOTYPE: -
	LINEAR: ± 0.5	DESIGN: D.M.M. 3/06/2021	PART NUMBER: -
	ANGULAR: ± 0.5	CHECK: O.M.L.T. 3/06/2021	REVIEW: -
	ENTER TO CENTER: ± 0.2	CHECK: O.M.L.T. 3/06/2021	
			SK-5406